



# ***COLD AIR SYSTEM***

Installation Instructions for:  
Part Number 21-494  
2004 Volkswagen Golf R32 VR6 3.2LV6

**ADVANCED ENGINE MANAGEMENT INC.**  
2205 126<sup>TH</sup> Street, Unit A Hawthorne, CA. 90250  
Phone: (310) 484-2322 Fax: (310) 484-0152  
[www.aempower.com](http://www.aempower.com)

Instruction Part Number: 10-7049

2004 Volkswagen Golf R32 VR6 3.2LV6 C.A.R.B. E.O. # Pending

Cold Air Intake Systems that are pending CARB approval are illegal in California except on racing vehicles which may never be used on public highways.

© Copyright 2004

Congratulations! You have just purchased the finest Air Induction & Filtration system for your car at any price!

The **AEM** Cold Air System is the result of extensive development on a wide variety of cars. Each system is engineered for the particular application. The **AEM** Cold Air System differs from all others in several ways. We take the inlet air from outside of the engine compartment where the inlet air is considerably cooler than the hot underhood air. The cooler inlet air temperature translates to more power during the combustion process because cool air is denser than warm air. **AEM** has conducted extensive inlet air temperature studies and we have seen temperature reductions of up to 50 degrees by pulling air from outside of the engine compartment. The air mass flow to the engine is increased because of the increased airflow *and* reduced inlet temperature, which translates to more power. The **AEM** Cold Air Systems are **50 states Street Legal** (some models and years still pending) and come with complete instructions for ease of installation.

Our system is constructed of lightweight aluminum and then painted with a zirconia based powder coat for superior heat insulating characteristics. The aluminum will not crack in extended use like plastic and it is actually lighter than plastic. The tube diameter and length are matched for each engine to give power over a broad rpm range. Unlike the plastic systems that use a continually diverging cross section, we take advantage of the acoustical energy in the duct to promote cylinder filling during the intake valve-opening event.

## Bill of Materials for:

### Part Number 21-494

1	2-579	Inlet Pipe
1	21-202	2.75" Air Filter
3	444.460.04	6mm Locknut
4	559999	6mmx25mmx1mm Washer
1	1228599	Rubber Mount
1	5-328	3.25" to 2.75" Reducer
1	103-BLO-5620	3.5" Hose Clamp
1	103-BLO-4820	3.0" Hose Clamp
1	10-7049	Instructions
1	10-922E	AEM Decal
2	10-922S	AEM Silver Decal
1	10-400W	White License Plate Frame
1	10-905	Warning Decal

Read and understand these instructions **BEFORE** attempting to install this product.

### 1) Getting Started

- a) Make sure vehicle is parked on a level surface.
- b) Set parking brake.
- c) Jack the front of the vehicle and support with properly rated jack stands.
- d) Lift the plastic battery cover and disconnect both battery terminals. Remove the short positive lead from the positive battery terminal. **(Fig. 1)**
- e) If engine has run within the past two hours let it cool down.

### 2) Removing the stock air inlet system

- a) Swing the fuse box on top of the battery upwards and remove the hinge from the plastic battery box.
- b) Remove the four screws along the top of the radiator support. **(Fig. 2)** Remove the two plastic covers.
- c) Remove the battery hold down bolt and remove the battery from the vehicle. **(Fig. 3)**
- d) Remove the three bolts that secure the plastic battery box in place. Two bolts are located at the rear of the battery, on either side of the plastic wire tunnel. The third bolt is located on the radiator side of the battery. **(Fig. 4)**
- e) Unlatch the plastic wire tunnel cover on the backside of the battery box. **(Fig. 5)** Swing the cover open and remove the wire harness for the plastic battery box.
- f) Open the plastic clip that secures the positive battery lead to the engine side of the plastic battery box. **(Fig. 6)** Remove the plastic battery box from the vehicle.
- g) Remove the plastic battery tray from the vehicle by removing the four bolts that secure it. **(Fig. 7)**
- h) Unplug the wire connector from the MAF sensor. **(Fig. 8)**
- i) Loosen the hose clamp that secures the inlet tube to the MAF sensor. Pull the inlet tube clear of the MAF sensor. **(Fig. 9)**
- j) Remove the nut that secures the lower intake tube to the inner fender well. **(Fig. 10)**
- k) Remove the two bolts that secure the air box. **(Fig. 11)** Remove the air box, MAF sensor, and lower inlet tube from the vehicle.
- l) Remove the two screws securing the MAF sensor to the air box and set the MAF sensor aside in a safe place where it won't be damaged.
- m) Remove the screws securing the driver's side fender liner in place. Fold the fender liner back and out of the way to allow access to the area behind the front bumper.
- n) Remove the plastic cover behind the driver's side headlight. The cover is secured with three plastic rivets. The rivets are released by pushing the center of the plastic rivet with a small, pointed object. Two rivets are located at the top of the plastic cover, in the radiator support. **(Fig. 12)** The third rivet is accessible from under the car. **(Fig. 13)** Pull the plastic cover out of the engine bay. **(Fig. 14)**
- o) Remove the wiring harness from the plastic cradle in the fender well by pulling straight up. **(Fig. 15)**
- p) Move the harness to the other side of the negative battery cable by removing the negative battery cable from its plastic clip. Pass the wire harness under the negative battery cable and replace the battery cable in its plastic clip. **(Fig. 16)**
- q) From inside the fender well, remove the plastic wire harness cradle from the fenderwell by squeezing the two tabs on the back. **(Fig. 17)**

### 3) Installing the AEM Cold Air System

- a) When installing the **AEM** intake, DO NOT completely tighten the hose clamps, MAF sensor assembly or the mounting tab hardware until instructed to do so later in these instructions.
- b) Install the rubber mount in the outermost hole to the rear of the large opening behind the headlight. Insert the rubber mount from below **(Fig. 18)** and secure it with a large fender washer and lock nut from the top. **(Fig. 19)**
- c) Place a large fender washer on the stud that originally secured the lower intake tube in place. **(Fig. 20)**
- d) Install the reducer coupler onto the MAF sensor using the 3.25" hose clamp. The reducer coupler goes on the end that was originally in the air box. **(Fig. 21)**
- e) Insert the upper end of the **AEM** inlet pipe into the small end of the reducer coupler with the 2.75" hose clamp. The upper end is the end with the **AEM** decal.
- f) Feed the **AEM** inlet pipe into the engine bay and fender well. The lower bracket should line up with the rubber mount installed in step 3b. The upper mount should line up with the stud originally used to mount the lower intake tube.
- g) Install a large fender washer and lock nut onto both the rubber mount and the stud. **(Fig. 22 & 23a)** Refer to the following diagram for proper rubber mount installation.

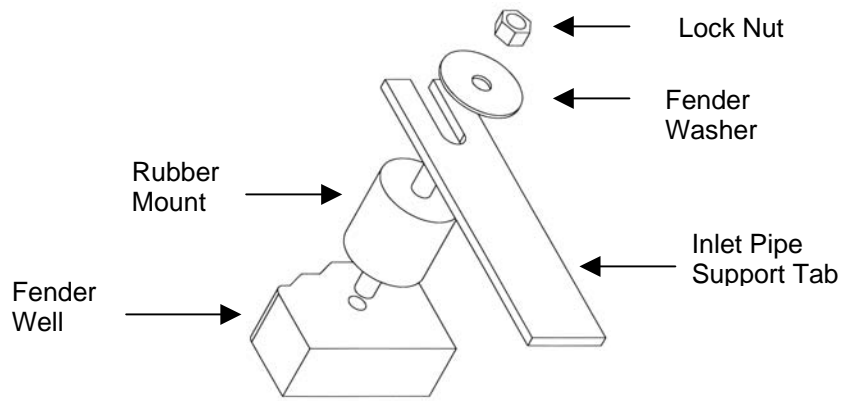

- h) Insert the MAF sensor into the factory upper intake tube using the original hose clamp. Rotate the MAF sensor so that the wire connector is in approximately the factory location. Plug in the MAF sensor wire connector. Refer to **Fig. 9**.
- i) Install the **AEM** air filter onto the bottom of the **AEM** inlet pipe using the supplied hose clamp. (**Fig. 23b**)
- j) Adjust the inlet system for best fitment and snug the hose clamps and locknuts down. (Make sure that no part of the inlet system comes into contact with any part of the vehicle.)**
- k) Re-assemble the vehicle in the reverse order of disassembly. The large plastic cover behind the headlights that was retained by the three plastic rivets does not need to be reinstalled.
- l) At this point the entire intake tube and filter can be re-adjusted for position and alignment. Make sure that no part of the **AEM** intake rubs anywhere along its length.
- m) Connect the battery cables.
- 4) **Final inspection of installed components**
  - a) Verify that no items are left loose in the engine compartment before you do the initial start up.

**For Technical Inquiries  
Please E-Mail us at  
tech@aempower.com**

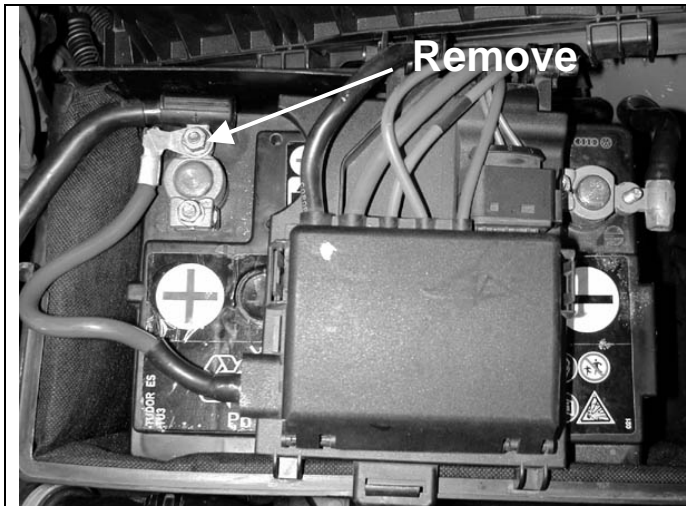

Fig. 1

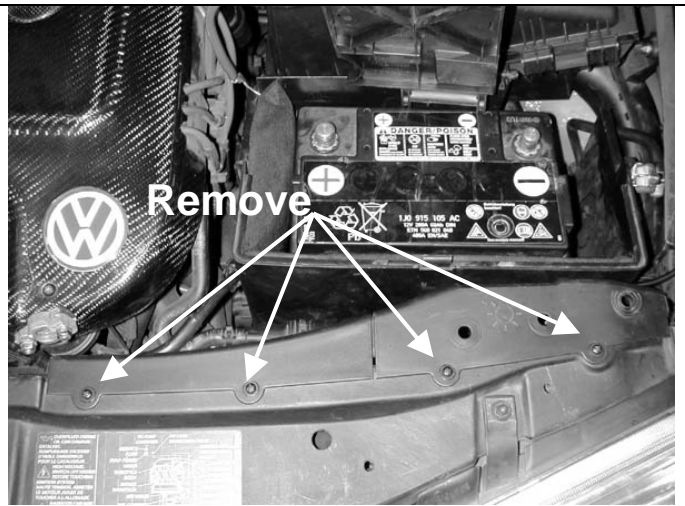

Fig. 2



Fig. 3

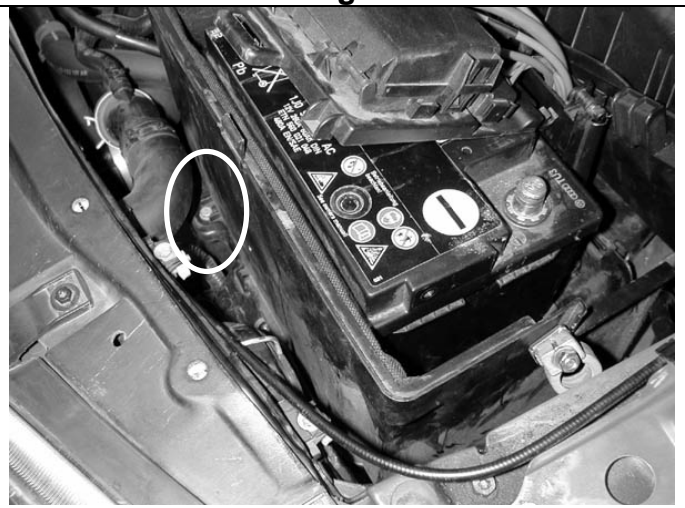

Fig. 4

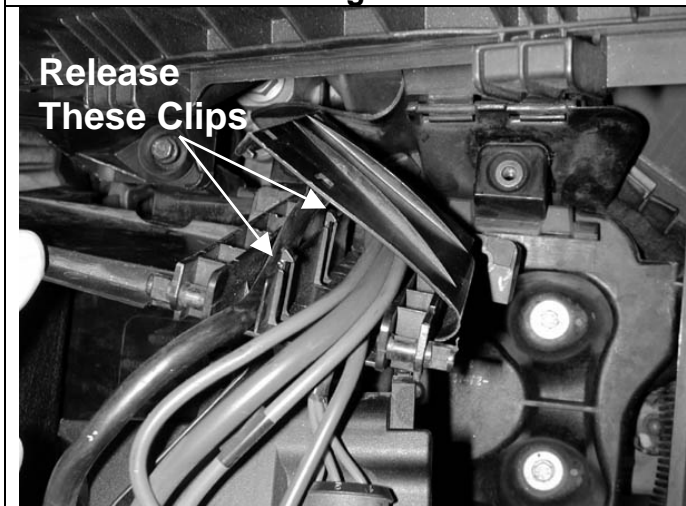

Fig. 5

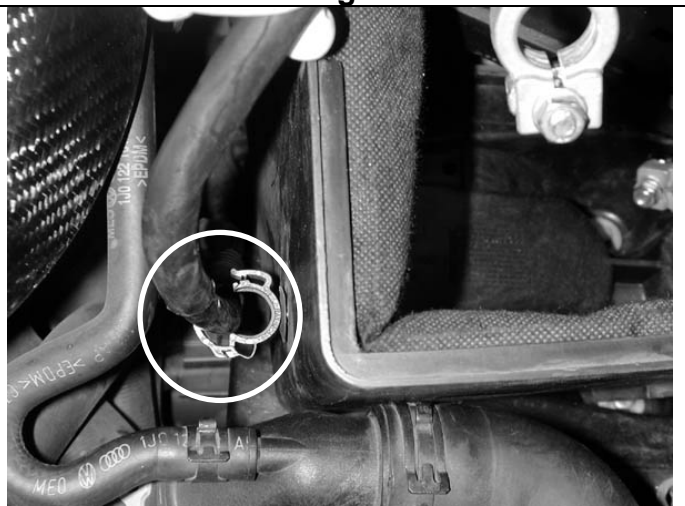
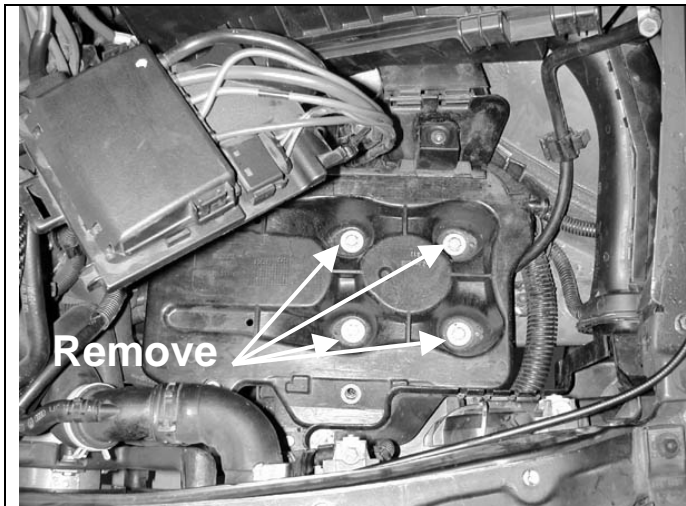

Fig. 6



**Fig. 7**



**Fig. 8**



**Fig. 9**



**Fig. 10**

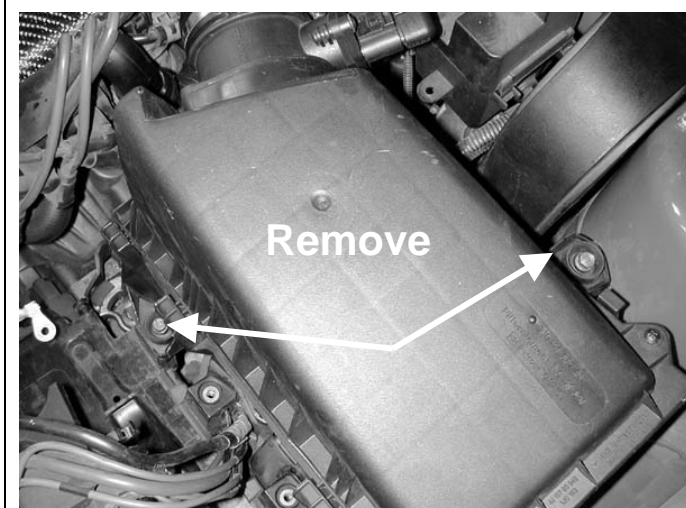

**Fig. 11**

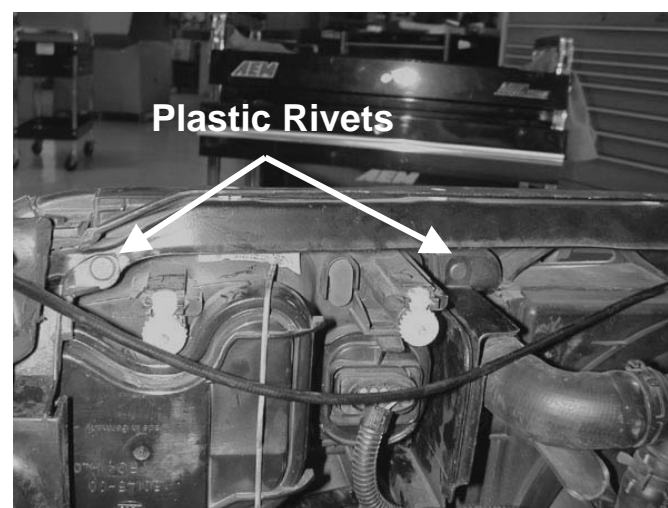

**Fig. 12**

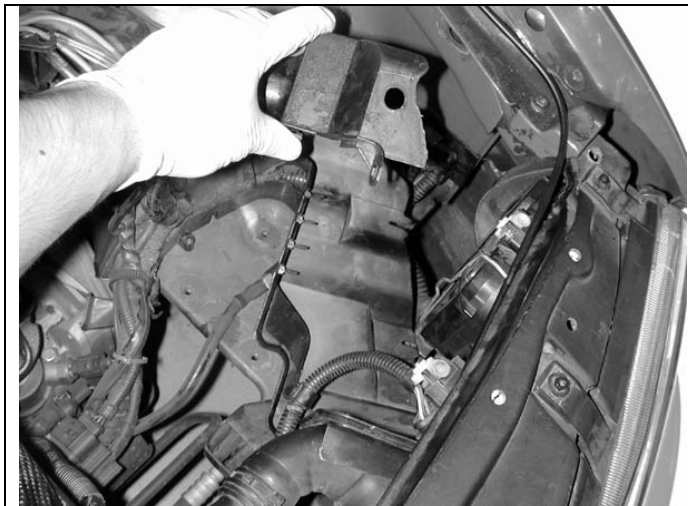

**Fig. 13**

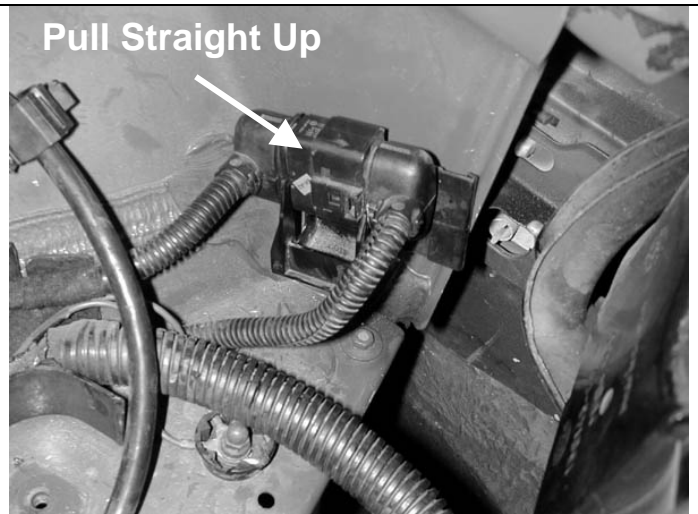

**Fig. 14**

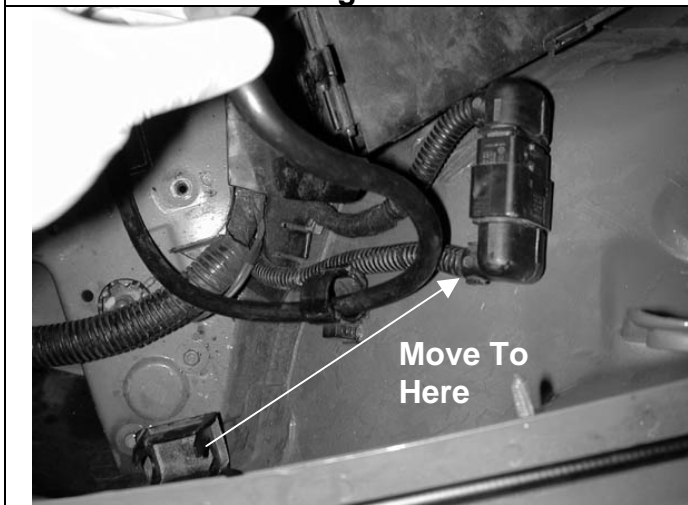

**Fig. 15**

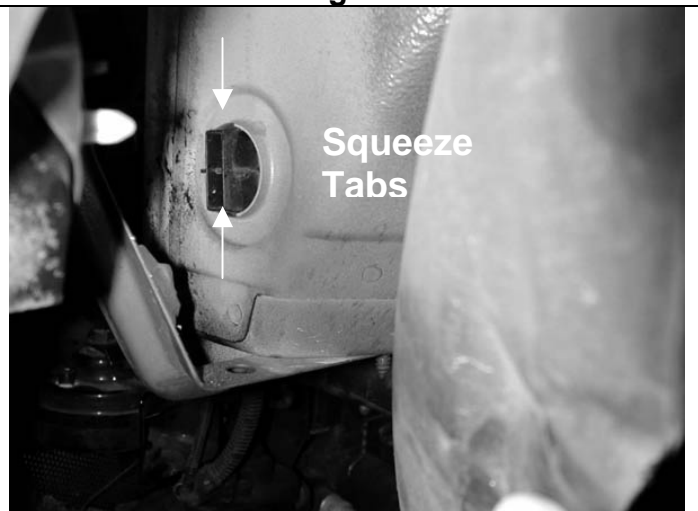

**Fig. 16**

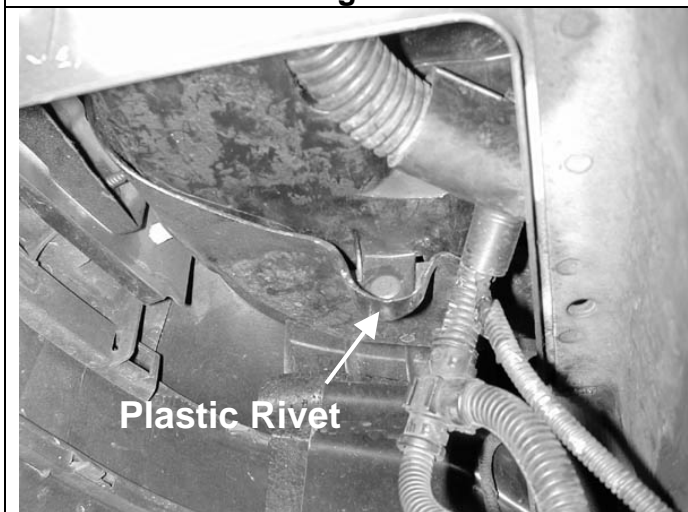

**Fig. 17**

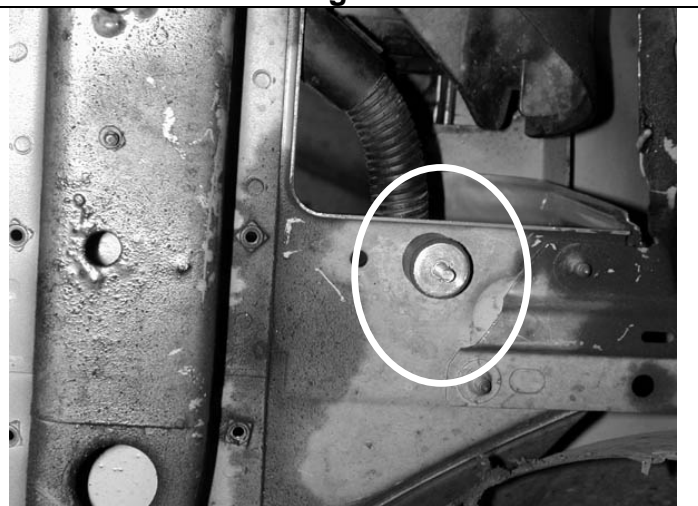

**Fig. 18**



**Fig. 19**

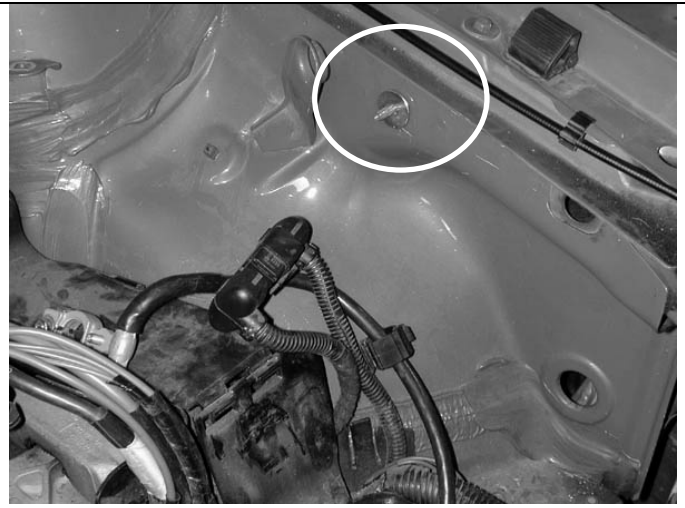

**Fig. 20**



**Fig. 21**



**Fig. 22**



**Fig. 23a**



**Fig. 23b**





**Before**



**After**