



Equipped with AEM® Dryflow™ Filter
No Oil Required!

INSTALLATION INSTRUCTIONS

PART NUMBER:21-8408DC

| | | | |
|-----------|--------|---------|---------|
| 2010-2018 | TOYOTA | Tundra | V8-4.6L |
| 2007-2021 | TOYOTA | Tundra | V8-5.7L |
| 2007-2021 | TOYOTA | Sequoia | V8-5.7L |

**LEGAL IN CALIFORNIA ONLY FOR RACING VEHICLES
WHICH MAY NEVER BE USED, REGISTERED
OR LICENSED FOR USE UPON A HIGHWAY.**

See aemintakes.com for CARB status on each part for a specific vehicle

PARTS LIST

| | Description | Qty. | Part Number |
|---|-----------------------------------|------|-------------|
| A | Air Filter | 1 | 21-2059DK |
| B | Inlet Pipe | 1 | 2-84081C |
| C | Heat Shield | 1 | 20-8408 |
| D | Hose, Adapter 4"/3.5" X 3" | 1 | 5-435 |
| E | Edge Trim | 1 | 102495 |
| F | Hose; 5/8"ID X 21"L | 1 | 5-7021 |
| G | Rubber Edge Trim 19" | 1 | 102451 |
| H | Rubber Edge Trim 6" | 1 | 8-3006 |
| I | Mount, Rubber 1" X 8mm | 2 | 1228560 |
| J | Spacer, 1.00 OD .256 ID X 1" | 1 | 2-658 |
| K | Bolt, Hex/Flange M6-1 X 40 | 1 | 1-2075 |
| L | Bolt, Hex/Flange M6-1 X 20 | 1 | 1-2038 |
| M | Washer, 8mm Soft Mount | 4 | 559960 |
| N | Washer, 6mm Soft Mount | 2 | 08160 |
| O | Nut, M8 Hex Serrated | 4 | 444.460.08 |
| P | 1/2" Bnd. Hose Clamp, 3.56"-4.50" | 2 | 9464 |
| Q | 1/2" Bnd. Hose Clamp, 3.15"-4.00" | 1 | 9456 |
| R | Hose Clamp #10 Mini | 2 | 08411 |

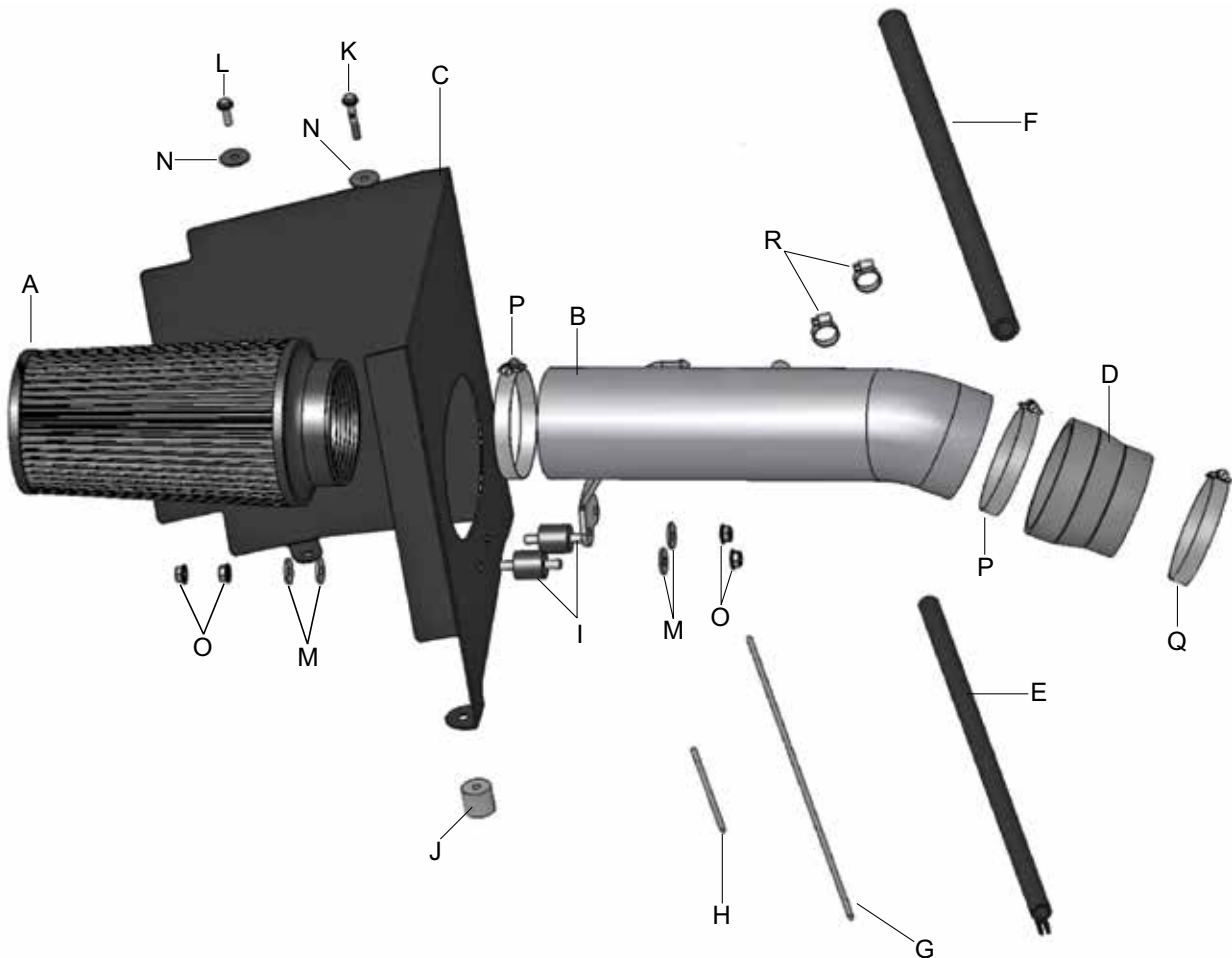

Read and understand these instructions **BEFORE** attempting to install this product. Failure to follow installation instructions and not using the provided hardware may damage the intake tube, throttle body and engine.

1. Preparing Vehicle

- a. Make sure vehicle is parked on level surface.
- b. Set parking brake.
- c. If engine has run in the past two hours, let it cool down.
- d. Disconnect negative battery terminal.
- e. Do not discard stock components after removal of the factory system.

2. Removal of stock system



a. Factory airbox system installed.



b. Remove the small hose located on the back of the inlet resonator.



c. Pinch the hose clamp, and remove the larger hose from the inlet resonator.



d. Release the zip tie from the airbox lid. Unplug the wire harness plug from the mass air flow sensor.



e. Unclip the four clips securing the airbox lid to the lower airbox. This is the first clip.



f. Unclip the second airbox clip.



g . Unclip the third airbox clip.



h. Unclip the fourth airbox clip.



i. Loosen the hose clamp securing the stock inlet tube to the throttle body.



j. Remove the stock inlet tube and airbox lid assembly.



k. Remove the stock air filter from the lower airbox. box.



l. Unscrew the two bolts that secure the lower airbox. The location of the first bolt is pictured above.



m. Remove the second bolt securing the lower airbox.



n. Stock airbox system removed from the engine bay.



o. Remove the bolt securing the windshield washer fluid container.



p. Within the engine bay, locate the ground bolt located on the passenger side inner fender. Remove the ground bolt closest to the firewall.



q. Pull the ground strap away from the frame.



r. Remove the larger stock breather hose from the vehicle.

3. Installation of AEM® intake system.

a. When installing the intake system, do not completely tighten the hose clamps or mounting hardware until instructed to do so.



b. Install the supplied spacer over the windshield washer fluid container support.



c. Insert the heat shield into the engine bay, aligning the heat shield's tab with the spacer installed in step 3b.



d. Align the second heat shield tab with the fender well hole as shown. Secure the heat shield in place by securing the tab to the fender well with a supplied bolt and washer.



e. Align the third heat shield tab with the bolt hole that was exposed from removing a ground strap in step 2p.



f. Using the bolt removed in step 2p, secure the ground strap and heat shield tab to the inner fender.



g. Assemble a washer to the long bolt (#1-2075). Guide the bolt through the heat shield tab, spacer, and windshield washer bottle support. Tighten the hardware to secure the heat shield to the vehicle.



h. Insert the two rubber mounts into the heat shield as shown. Secure the rubber mounts to the inner side of the heat shield with a washer and serrated nut.



i. Install the provided 5/8" hose onto the breather hose inlet and secure with a hose clamp.



j. Install the reducer coupler onto the throttle body and secure with the provided hose clamp.



k. Remove the MAF sensor from the stock inlet tube and install it in the AEM® intake pipe. Use the stock screws to secure the MAF sensor to the intake pipe.



l. Insert the intake pipe into the reducer coupler while also aligning the intake pipe's bracket to the rubber mounts protruding from the heat shield. Secure the intake pipe to the reducer coupler with a provided hose clamp and secure the intake pipe's bracket to the rubber mounts with the provided washers and serrated nuts.



m. Route the open end of the 5/8" breather hose to the intake pipe nipple and secure in place with the supplied hose clamp. Route the stock 5/32" hose to the same location, it should slide snugly over the intake pipe's smaller nipple.



n. Secure the tree mount zip tie into the heat shield's slot as shown. Connect the MAF wiring harness plug to the MAF sensor.



o. Install the supplied edge trim around the heat shield opening. Position the AEM® air filter into the heat shield opening and secure to the intake pipe with a provided hose clamp.



p. Attach the edge trim to the top of the heat shield edges as shown.



Factory airbox system installed



AEM® intake system installed

4. Reassemble Vehicle

- a. Position the inlet pipes for the best fitment. Be sure that the pipes or any other components do not contact any part of the vehicle. Tighten the rubber mount, all bolts, and hose clamps.
- b. Check for proper hood clearance. Re-adjust pipes if necessary and re-tighten them.
- c. Inspect the engine bay for any loose tools and check that all fasteners that were moved or removed are properly tightened.
- d. Reconnect negative battery terminals and start engine. Let the vehicle idle for 3 minutes. Perform a final inspection before driving the vehicle.

5. Service and Maintenance

- a. It is recommended that you service your AEM® Dryflow™ filter every 20,000 miles for optimum performance. Use AEM Dryflow cleaning kit part # 21-110.
- b. Use aluminum polish to clean your polished AEM® intake tube.
- c. Use window cleaner to clean your powder coated AEM® intake tube. **(NOTE: DO NOT USE aluminum polish on powder coated AEM intake tubes)**

For technical inquiries
e-mail us at
sales@aemintakes.com
or
call us at
800.992.3000

AEM Air Intake System Warranty Policy

AEM® warrants that its intake systems will last for the life of your vehicle. AEM will not honor this warranty due to mechanical damage (i.e. improper installation or fitment), damage from misuse, accidents or flying debris. AEM will not warrant its powder coating if the finish has been cleaned with a hydrocarbon-based solvent. The powder coating should only be cleaned with a mild soap and water solution. Proof of purchase of both the vehicle and AEM intake system is required for redemption of a warranty claim.

This warranty is limited to the repair or replacement of the AEM part. In no event shall this warranty exceed the original purchase price of the AEM part nor shall AEM be responsible for special, incidental or consequential damages or cost incurred due to the failure of this product. Warranty claims to AEM must be transportation prepaid and accompanied with dated proof of purchase. This warranty applies only to the original purchaser of product and is nontransferable. Improper use or installation, use for racing, accident, abuse, unauthorized repairs or alterations voids this warranty. AEM disclaims any liability for consequential damages due to breach of any written or implied warranty on all products manufactured by AEM. Warranty returns will only be accepted by AEM when accompanied by a valid Return Merchandise Authorization (RMA) number. Credit for defective products will be issued pending inspection. Product must be received by AEM within 30 days of the date RMA is issued.

If you have a warranty issue, please call (800) 992-3000 and our customer service department will assist you. A proof of purchase is required for all AEM warranty claims.

**LEGAL IN CALIFORNIA ONLY FOR RACING VEHICLES
WHICH MAY NEVER BE USED, REGISTERED
OR LICENSED FOR USE UPON A HIGHWAY.**

See aemintakes.com for CARB status on each part for a specific vehicle