



Equipped with AEM® Dryflow™ Filter

No Oil Required!

## INSTALLATION INSTRUCTIONS

**PART NUMBER: 21-9034**

---

YEAR MAKE	MODEL	Engine Info			
2006-2007 CHEVROLET	2500HD Classic	V8-6.6L DSL	C.A.R.B. E.O.		D-670-13
2006-2007 CHEVROLET	3500HD Classic	V8-6.6L DSL	C.A.R.B. E.O.		D-670-13
2006-2007 GMC	2500HD Classic	V8-6.6L DSL	C.A.R.B. E.O.		D-670-13
2006-2007 GMC	3500HD Classic	V8-6.6L DSL	C.A.R.B. E.O.		D-670-13

## PARTS LIST

ITEM	DESCRIPTION	QTY.	PART NO.
A	TUBE, INTAKE, 2006 CHEVY/GMC 2500HD 6.6L	1	9-0428
B	HEAT SHIELD, 2006 CHEVY/GMC 2500HD 6.6L	1	20-8024-1
C	HOSE, COUPLER, SILICONE, 4.25 X 2.5	1	5-1066
D	AIR FILTER, DRYFLOW®, 5" X 8" DSL	1	21-2258DK
E	INSERT, 5" ADAPTER, DIESEL A/F ASSY	1	5-2279
F	EDGE TRIM, BULB, 7.0"	1	8-4007
G	EDGE TRIM, BULB 11"	1	102468
H	EDGE TRIM, BULB 20"	1	102494A
I	CLAMP, HOSE, 4.0-5.0" DIA.	2	9472
J	CLAMP, HOSE, #80	1	KITHS80
K	RUBBER ISOLATOR STUD MOUNT, M6 X 0.625"	1	1228598
L	BOLT, ALLEN, M4-0.7 x 8MM, MAF SENSOR	2	1-2105
M	BRACKET, " L", 1.0 X 1.0	1	32-3087
N	BOLT, HEX, M6-1.0 X 16MM	1	07703
O	NUT, HEX, FLANGED, M6-1.0	2	444.460.04
P	WASHER, SPLIT, FOR M6	1	1-3025
Q	WASHER, FLAT, 1.0 DIA.	3	08160

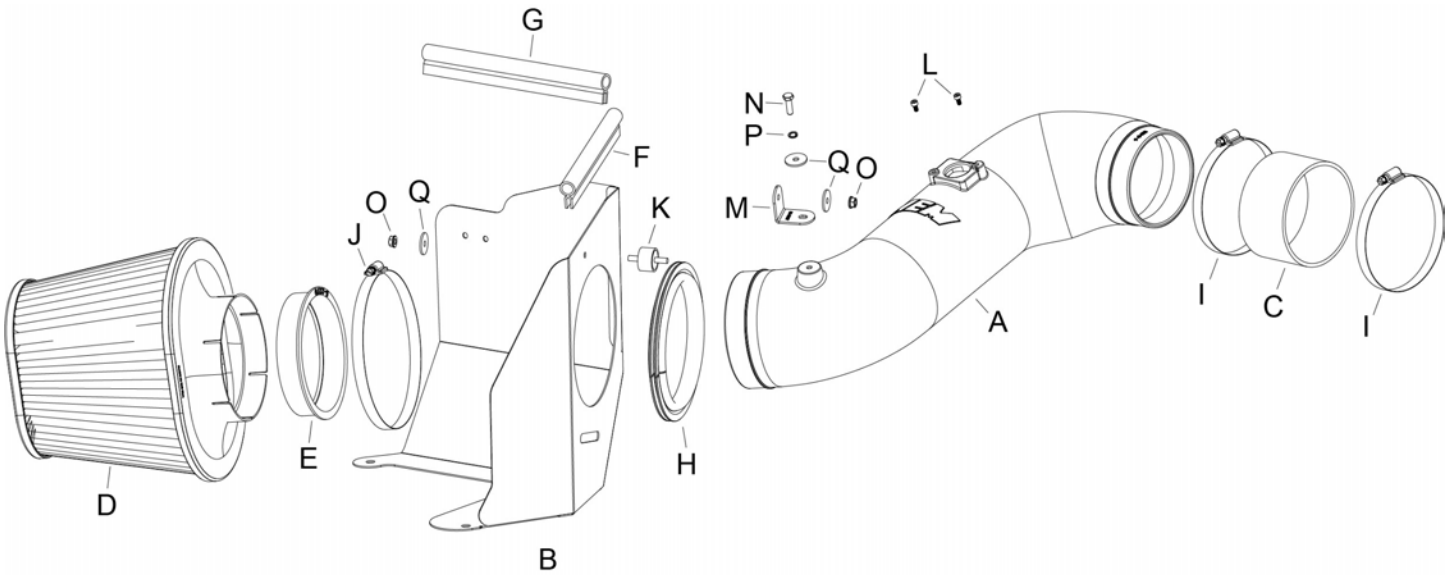

Read and understand these instructions **BEFORE** attempting to install this product. Failure to follow installation instructions and not using the provided hardware may damage the intake tube, throttle body and engine.

The AEM<sup>®</sup> intake system is a performance product that can be used safely during mild weather conditions. During harsh and inclement weather conditions, you must return your vehicle to stock OEM airbox and intake tract configuration. Failure to follow these instructions will void your warranty.

## 1. Preparing Vehicle

- a. Make sure vehicle is parked on a level surface.
- b. Set parking brake.
- c. If engine has run in the past two hours, let it cool down.
- d. Disconnect negative battery terminals on both batteries.
- e. Do not discard stock components after removal of the factory system.

## 2. Removal of stock system



A. Open vehicle hood. Stock intake system shown.



B. Depress the snap tab on the MAF sensor connector as shown and pull it to disconnect the harness from the sensor.



C. Loosen the two hose clamps retaining the stock intake tube at both ends and remove the tube from the engine bay.



D. Pull up on the stock filter air box starting on the side closer to the engine to "pop" it free from the 3 mounting grommets. Remove the air box assembly from the engine bay.



### 3. Installation of AEM Intake System

- a. When installing the intake system, do not completely tighten the hose clamps or mounting hardware until instructed to do so.



A. Install the factory MAF sensor onto the mounting pad of your AEM® Cold Air Intake tube using the two M4 Allen bolts provided. Tighten the bolts with a 3mm Allen key.



B. Install the silicone hose onto the engine air inlet using a #72 hose clamp. Fully tighten that hose clamp and then loosely install another hose clamp onto the open end of the hose.



C. Install the M6 rubber isolator mount into the hole over the large opening in the heat shield, then install one flat washer and one M6 nut on the inside of the heat shield as shown. Tighten the nut.



D. Install the "L" mounting bracket onto the end of the rubber isolator mount using another flat washer and M6 nut. Note that the slotted hole in the bracket is facing down. Leave the M6 nut loose for Step I.

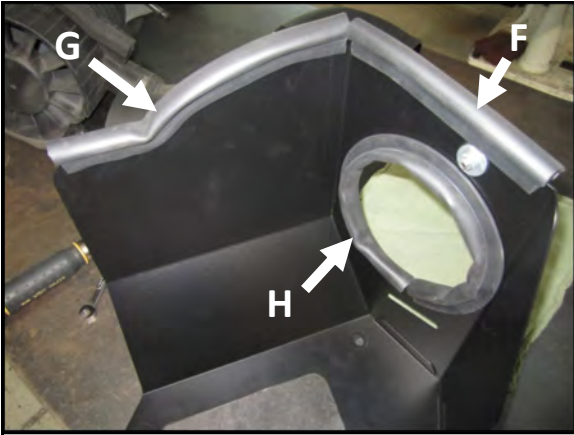

E. Install the longer bulb seal molding around the inside of the large outlet hole in the heat shield. Trim any excess bulb seal. Then install the two shorter bulb seal moldings along the top edge of the heat shield as shown.



F. Install the AEM® heat shield into the engine bay using 3 of the stock M6 bolts with washers from the stock mounting plate as shown and tighten the bolts.



G. Install your AEM® Cold Air Intake tube, first into the heat shield opening and then into engine inlet hose as shown. Do not tighten the inlet hose clamp yet.



H. Secure the intake tube to the "L" bracket using one M6 x 16MM bolt, one split washer, and one flat washer as shown and tighten the bolt.



I. Now tighten the upper M6 nut to secure the "L" bracket to the rubber mount.

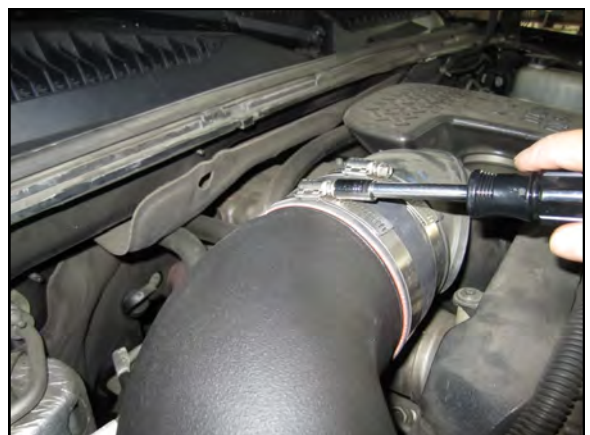

J. Fully seat the intake tube into the engine inlet hose and tighten the hose clamp.



K. Install the large hose clamp over the filter outlet, and then insert the larger filter base adapter into the outlet of your new AEM® Dryflow™ Air Filter.



L. Install your new AEM® Dryflow™ Air Filter assembly onto the inlet of the intake tube inside the heat shield. Align the filter as shown and tighten the large hose clamp at the filter base.



M. Re-connect the MAF harness to the MAF sensor as shown.



N. AEM-21-9034 Cold Air Intake installed.

#### 4. Reassemble Vehicle

- a. Position the inlet pipes for the best fitment. Be sure that the pipes or any other components do not contact any part of the vehicle. Tighten any rubber mounts (if applicable), all bolts, and hose clamps.
- b. Check for proper hood clearance. Re-adjust pipes if necessary and re-tighten them.
- c. Inspect the engine bay for any loose tools and check that all fasteners that were moved or removed are properly tightened.
- d. Reconnect the negative battery terminals on both batteries and start the engine. Let the vehicle idle for 3 minutes. Perform final inspection before driving the vehicle.

#### 6. CARB Sticker Placement

- a. The C.A.R.B. exemption sticker, (attached), must be visible under the hood so than an emissions inspector can see it when the vehicle is required to be tested for emissions. California requires testing every two years, other states may vary.

#### 7. VECI (Vehicle Emission Controls Information)

Most General Motors trucks (including Chevrolet) have the Vehicle Emissions Certification Information (VECI) Label affixed to the air filter box. In order to be compliant with California emissions laws, the label **MUST** remain in the engine compartment. If the Vehicle Emission Control Information label is removed during modification, a new replacement label must be obtained and installed in a readily visible position in the engine compartment. The label shall not be affixed to any equipment which is easily detached from the vehicle. We recommend that the label is affixed to the underside of the hood adjacent to the hood latch. The label is Vehicle Identification Number dependent and can be ordered from the vehicle dealership. In order to receive the proper decal, please bring your VIN with you. Failure to have the VECI under the hood may result in failure of a pre-registration smog test.

#### 8. Service and Maintenance

- a. AEM Induction Systems requires cleaning the intake system's air filter element every 100,000 miles. When used in dusty or off-road environments, our filters will require cleaning more often. We recommend that you visually inspect your filter once every 25,000 miles to determine if the screen is still visible. When the screen is no longer visible some place on the filter element, it is time to clean it. To clean, purchase our Synthetic Air Filter Cleaner, part number 1-1000 and follow the easy instructions.
- b. Use a damp cloth or window cleaner to clean your powder coated AEM<sup>®</sup> intake tube.

**NOTE: DO NOT USE aluminum polish on powder coated AEM<sup>®</sup> intake tubes.**

For Technical inquiries  
E-mail us at  
sales@aemintakes.com  
Or  
Call us at  
800.992.3000



## **AEM<sup>®</sup> Air Intake System Warranty Policy**

AEM<sup>®</sup> warrants that its intake systems will last the life of your vehicle. AEM<sup>®</sup> will not honor this warranty due to mechanical damage (i.e. improper installation or fitment), damage from misuse, accidents or flying debris. AEM<sup>®</sup> will not warrant its powder coating if the finish has been cleaned with a hydrocarbon-based solvent. The powder coating should only be cleaned with a mild soap and water solution. Proof of purchase of both the vehicle and AEM<sup>®</sup> intake system is required for redemption of a warranty claim.

This warranty is limited to the repair or replacement of the AEM<sup>®</sup> part. In no event shall this warranty exceed the original purchase price of the AEM<sup>®</sup> part nor shall AEM<sup>®</sup> be responsible for special, incidental or consequential damages or cost incurred due to the failure of this product. Warranty claims to AEM<sup>®</sup> must be transportation prepaid and accompanied with dated proof of purchase. This warranty applies only to the original purchaser of product and is nontransferable. Improper use or installation, use for racing, accident, abuse, unauthorized repairs or alterations voids this warranty. AEM disclaims any liability for consequential damages due to breach of any written or implied warranty on all products manufactured by AEM<sup>®</sup>. Warranty returns will only be accepted by AEM<sup>®</sup> when accompanied by a valid Return Merchandise Authorization (RMA) number. Credit for the defective products will be issued pending inspection. Product must be received by AEM<sup>®</sup> within 30 days of the date RMA is issued.

If you have a warranty issue, please call (800) 992-3000 and our customer service department will assist you. A proof of purchase is required for all AEM<sup>®</sup> warranty claims.