

AEM[®]

ENGINEERED TO OUTPERFORM

Part Number 30-5130 Analog Wideband Air/Fuel Ratio Gauge

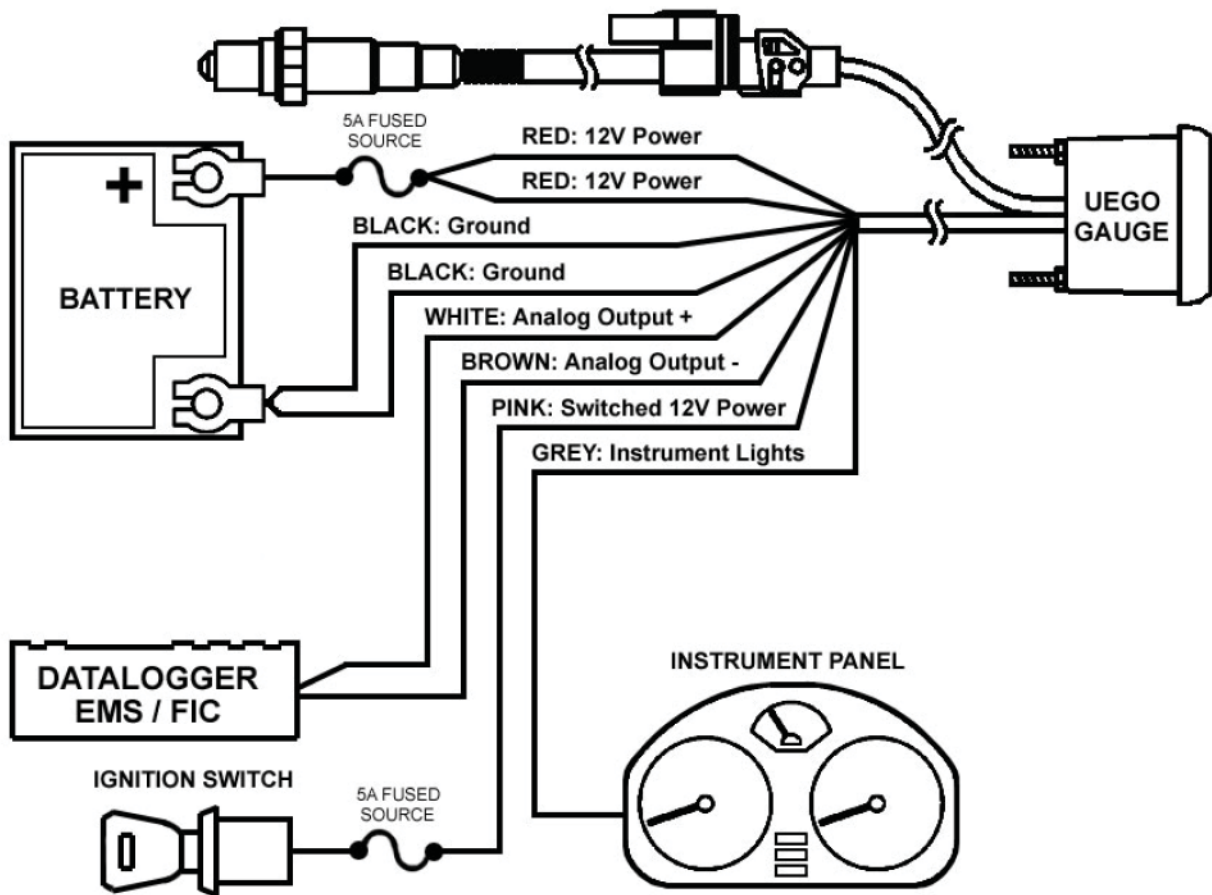

Figure 1. Wiring Schematic

AEM Gauge-Type UEGO Controller Parts

- 1 x 35-5130(B/W) UEGO Gauge Assembly
- 1 x 30-2001 UEGO Sensor
- 1 x 35-8535 Install Kit (O2 Bung with 6 Butt Connectors)
- 1 x 10-5130 Installation Instructions
- 1 x 35-3411 8-Pin Power Harness
- 1 x 35-3400 6-Pin Sensor Harness
- 1 x 35-8529S Silver Bezel

INSTALLATION

1. Disconnect the negative battery cable.
2. Secure the gauge in a 2 1/16th (52MM) mounting hole with the supplied bracket.
3. Plug the 8-wire power harness into the mating connector on the back of the gauge and connect the wires as shown in Figure 1. Note: the locating tabs on the side of the connector should be nearest the center of the gauge.
4. Mount the sensor as shown in figure 2.
5. Connect the sensor to the gauge using the 6-wire sensor cable. The connector with the grey latch connects to the sensor. The single-row connector connects to the back of the gauge. The locating tables on the single-row connector should be farthest from the center of the gauge.

RED - Connect **BOTH** RED wires to a constant 12 volt power source utilizing a 5A fuse.

BLACK – Connect **BOTH** BLACK wires to a clean power ground.

PINK - Connect to a switched 12 volt power source utilizing a 5A fuse.

GREY - Connect to instrument lighting circuit supply voltage.

*WHITE - Connect to Lambda + Input.

*BROWN - Connect to Lambda – input. (Must be connected if Lambda + is used)

**optional – only needed if using the available differential analog output*

Wiring notes:

RED - When wired as shown above, the gauge will park the needle upon powering down. Alternatively, both RED wires can be connected to a switched, fused 12 volt power source. With both RED wires and the PINK wire connected to switched power, the needle will remain at its current position upon powering down. For both power connection methods, the needle will rotate to the parked position before rotating to the value of the current operating condition upon powering up.

GREY – The GREY wire is used to control the lighting intensity of the gauge. Maximum lighting intensity is achieved when the GREY wire is connected to 12 volts. Minimum lighting intensity is achieved when the GREY wire is not connected. The instrumentation illumination on many vehicles is controlled by varying the supply voltage to the instrument panel lights. When the GREY wire is connected to the instrument panel supply voltage, the intensity of the gauge is controlled by the dimmer switch on the dash.

WHITE – The WHITE wire should be connected to the Lambda + input on the EMS or the analog + input on a similar device.

BROWN – The BROWN wire should be connected to the Lambda – input or the analog – input. If the EMS or similar device does not have a – input, the BROWN wire should be connected to a sensor ground. If no sensor ground is available, the BROWN wire should be connected to a power ground. **Note: The BROWN wire must be connected in order to get correct readings from the analog output.**

Sensor Mounting

A weld-in M18 X 1.5 boss is supplied for sensor installation. Mount the O2 sensor in the exhaust system at least 18 inches downstream from the exhaust port. If you anticipate high EGT's (over 800C), run a turbocharger, run at high RPM for extended periods of time or plan on running leaded race fuel then you must mount the sensor at least 36 inches or more downstream of the exhaust port as all of these can cause the sensor to overheat. **On turbocharged engines the UEGO sensor must be installed after the turbo charger, if not, the pressure differential will greatly affect the accuracy of the unit.** For accurate readings, the sensor must be mounted before catalytic converters and/or auxiliary air pumps. To prevent collection of liquids between the sensor housing and sensor element during the cold start phase, the installation angle should be inclined at least 10° from horizontal with the electrical connection upwards, see below. (Figure 2)

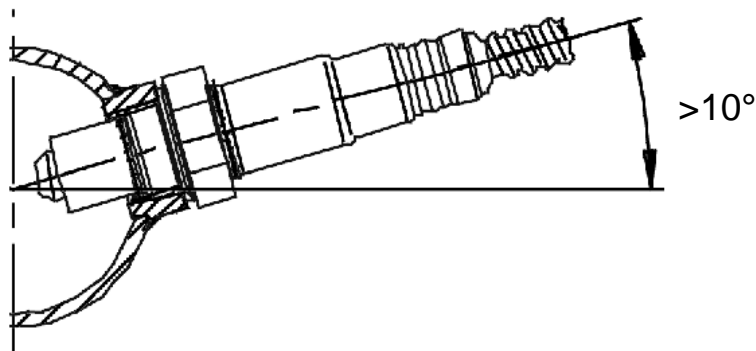

Figure 2. Minimum mounting angle for the UEGO Sensor

Changing the Bezel

The AEM UEGO Gauge comes with the black bezel installed. However, a silver bezel is also included in the gauge kit. To change the bezel, orient the gauge so you are looking at the faceplate. Rotate the bezel counter-clockwise to unscrew it from the gauge cup. The bezel, glass lens, and rubber spacer are all removable. Reassemble the gauge as shown below in Figure 3. **Do not over tighten the bezel when reassembling the gauge.**

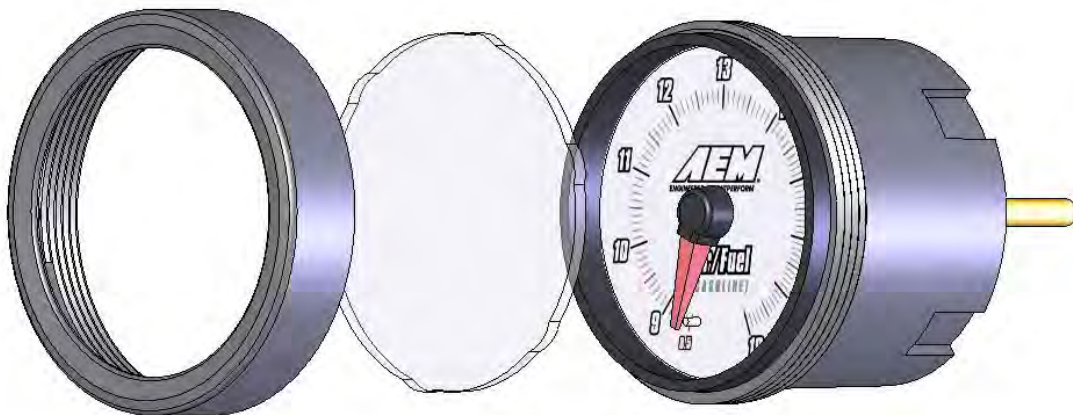

Figure 3. Changing Bezels

Backlighting

The Analog Wideband UEGO Gauge has 7 different backlight colors available to the end user, which closely match some of the more common factory dash panels: white, blue, green, red, orange, light blue, and aqua. To change the backlight color, rotate the backlighting switch using a small precision style screwdriver. The backlight switch is accessed through the small hole in the back of the gauge.

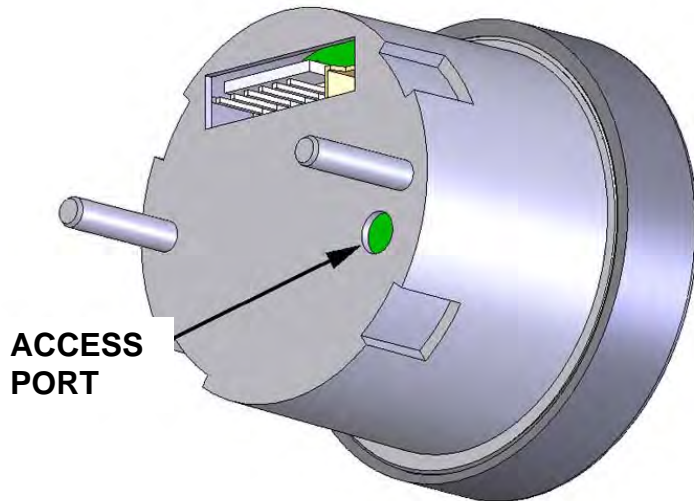

Figure 4. Backlighting Adjustment

Status Lights

The AEM UEGO gauge has two status lights, see Figure 4. The status light on the left is on during sensor warm up. The light will turn off once the sensor reaches its operating temperature, usually within 30 seconds. During sensor warm up, AFR readings may not be accurate. The status light on the right will flash if an error is detected. The status light will flash on and off a number of times, followed by a short pause. The error codes are listed below in Table 1.



Figure 4. Illuminated Status Lights

# of Flashes	Fault	Corrective Action
1-6	Sensor Wiring and/or sensor	Check sensor cable for broken wires/shorts
7	System voltage below 10 volts dc	Check electrical system for good connections and proper function

Table 1. Error Codes

Analog Output

The analog output from the AEM Analog Wideband Air/Fuel Ratio gauge is a linear dc voltage signal that varies from **0.5 Vdc at 8.5:1 AFR to 4.5Vdc at 18.0:1 AFR** over the operating range of the gauge. The signal is used for sending information to a data logger or an engine management system like the AEM EMS or F/IC. The transfer function for the output is listed below.

$$\text{AFR} = 2.375(\text{V}) + 7.3125$$

For example, if the output is 2.0 Vdc, the AFR is 12.06:1
 $2.375 * 2.0 + 7.3125 = 12.06$

Configuring the AEM EMS

With an EMS calibration open, go to Setup>Sensors>Oxygen Sensor #1(2)>O2 Sensor #1(2) Cal Table>Table, and enter the values below into the O2 Sensor #1(2) Cal Table.

Voltage	AFR	Voltage	AFR	Voltage	AFR	Voltage	AFR
0.00	8.43	1.40	10.64	2.81	13.99	4.21	17.31
0.16	8.43	1.56	11.02	2.96	14.34	4.37	17.69
0.31	8.43	1.72	11.40	3.12	14.72	4.52	18.05
0.47	8.43	1.87	11.75	3.28	15.10	4.68	18.05
0.62	8.79	2.03	12.13	3.43	15.46	4.84	18.05
0.78	9.17	2.18	12.49	3.59	15.84	4.99	18.05
0.94	9.55	2.34	12.87	3.74	16.20	NA	NA
1.09	9.90	2.50	13.25	3.90	16.58	NA	NA
1.25	10.28	2.65	13.61	4.06	16.96	NA	NA

Table 2. EMS Software Values

Connect the WHITE Analog Output + wire to the EMS Lambda input and the BROWN Analog Output – wire to the EMS sensor ground. Table 3 below lists the Lambda and Sensor ground pin locations for the different EMS part numbers.

AEM EMS P/N	Lambda #1 Pin	Lambda #2 Pin	Sensor GND Pin
30-1000/1001/1002/1040/1042	D14	D16	D21
30-1010/1012/1050/1052	C16	A23	C18
30-1020/1060	D7	D14	D12
30-1030/1031/1070	C13	C14	A16
30-1080	C16	C8	C14
30-1081	C16	B11	C14
30-1100/1101	B47	B48	B65
30-1110	1C	9C	13C
30-1120/1121/1130	B6	B14	B9
30-1220	30	31	60
30-1300	4	66	17
30-1310/1311/1312/1313	76	75	92
30-1320	71	73	34
30-1400	29	43	46
30-1401	44	43	46
30-1510	C2-31	C2-33	C2-32
30-1600/1601/1602/1603	19	NA	21
30-1610/1611/1612	46	52	50
30-1620/1621/1622/1623	29	55	30
30-1710	2N	4J	2C
30-1720	C3	D3	O3
30-1800	C3	A2	D4
30-1810	D19	B17	B19
30-1820/1821	A26	D25	C35

Table 3. EMS Pin Locations

Configuring the AEM F/IC

With an FIC calibration open, go to Setup>Aux Gauge, and complete the Aux gauge setup window as shown below in Figure 5.

Volts In	Meter Value
0.5	8.5
0.94	9.56
1.39	10.61
1.83	11.67
2.28	12.72
2.72	13.78
3.17	14.83
3.61	15.89
4.06	16.94
4.5	18

Figure 5. F/IC Aux Gauge Setup

Connect the WHITE Analog Output + wire to the Aux Gauge input and the BROWN Analog Output – wire to the sensor ground. Table 4 below lists the Lambda and Sensor ground pin locations for the different FIC part numbers.

AEM F/IC P/N	Lambda Pin	Sensor GND Pin
30-1910(X)	Pin 18 of 22-pin connector	Pin 5 of 22-pin connector
30-1930(X)	Pin 18 of 22-pin connector Pin 20 of 20-pin connector	Pin 5 of 22-pin connector

Table 4. F/IC Pin Locations

Connector Pinouts

The pinouts for the 6-pin sensor harness and 8 pin power harness are provided below in Figure 6.

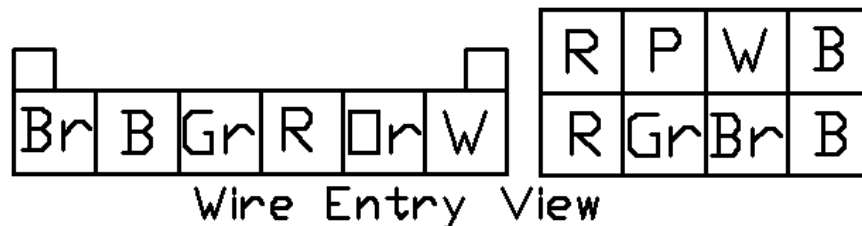

Figure 6. Harness Pinouts

Specifications

Gauge

Supply Current (nominal, peak)	1.3A, 2.7A peak
Differential Analog Outputs	1
Measuring Range	8.5:1 to 18:1 AFR Gasoline
Sensor Accuracy	0.1 AFR
Operating Voltage (nominal)	8.5-15 volts dc
Harness & Connector Temp Limit:	105C

Notes

The sensor contains a ceramic module and should not be subject to mechanical or thermal shock or it may be damaged. The sensor is not designed for operation on leaded fuels, doing so will dramatically shorten sensor life. Long term running in the rich region ($\text{Lambda} < 0.95$) will shorten sensor life. High exhaust temperatures (over 850C) will shorten sensor life. Engine oil consumption at a rate greater than 1 quart per 1,000 miles will shorten sensor life. With the UEGO Sensor installed, do not run the engine without power applied to the gauge.

Replacement O2 Sensor Components

30-2001	UEGO Sensor
35-4005	Mild Steel Oxygen Sensor Bung (welding required)
35-3411	8-Pin Power Harness
35-3400	6-Pin Sensor Harness

For technical inquiries
e-mail us at
sales@aemintakes.com
or
call us at
800.992.3000

AEM Air Intake System Warranty Policy

AEM® warrants that its intake systems will last for the life of your vehicle. AEM will not honor this warranty due to mechanical damage (i.e. improper installation or fitment), damage from misuse, accidents or flying debris. AEM will not warrant its powder coating if the finish has been cleaned with a hydrocarbon-based solvent. The powder coating should only be cleaned with a mild soap and water solution. Proof of purchase of both the vehicle and AEM intake system is required for redemption of a warranty claim.

This warranty is limited to the repair or replacement of the AEM part. In no event shall this warranty exceed the original purchase price of the AEM part nor shall AEM be responsible for special, incidental or consequential damages or cost incurred due to the failure of this product. Warranty claims to AEM must be transportation pre-paid and accompanied with dated proof of purchase. This warranty applies only to the original purchaser of product and is nontransferable. Improper use or installation, use for racing, accident, abuse, unauthorized repairs or alterations voids this warranty. AEM disclaims any liability for consequential damages due to breach of any written or implied warranty on all products manufactured by AEM. Warranty returns will only be accepted by AEM when accompanied by a valid Return Merchandise Authorization (RMA) number. Credit for defective products will be issued pending inspection. Product must be received by AEM within 30 days of the date RMA is issued.

If you have a warranty issue, please call (800) 992-3000 and our customer service department will assist you. A proof of purchase is required for all AEM warranty claims.