



INSTALLATION INSTRUCTIONS

MAKE: BMW
MODEL: 335i
YEAR: 2007-2009
ENGINE: L6-3.0L
NOTE: Cutting is required



2.75" Cat-Back (304SS)
49-36301

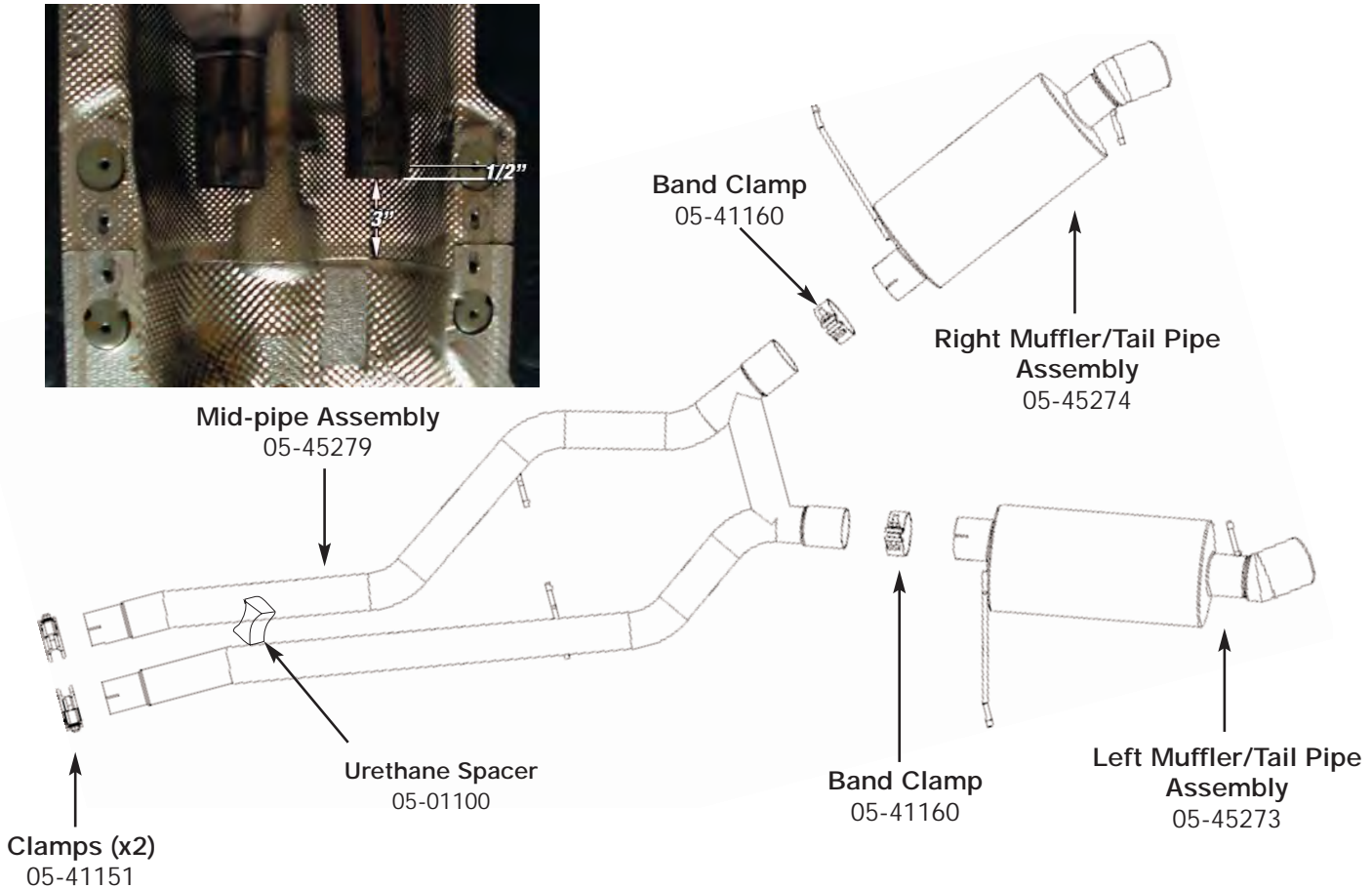
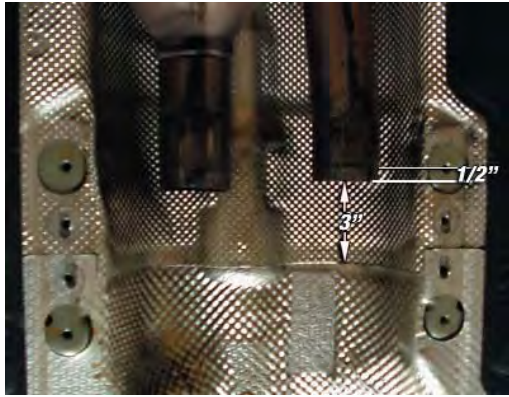

Step 1: (Read Instructions prior to installation) Remove your stock exhaust from the rear of your vehicle working your way forward. Take caution not to damage the factory isolation mounts as they will be reused. **It is recommended to not fully tighten the clamps until the entire system has been installed.**

Step 2: A urethane spacer (05-01100) is placed between the exhaust tubes from the factory to spread the pieces of the exhaust apart so that they will line up better to the OE exhaust tubes.

Step 3: OE exhaust tubes are to be cut. Remove cover plate and torx screws. The cut location is approximately 3" in front of the heat shield seam, approximately 1/2" behind the forward most cover plate attachment holes. (See Photo above)

Step 4: Install mid-pipe assembly with clamps and isolation mounts. If necessary loosen the forward flange joint to ease assembly. Do not fully tighten. Once the mid-pipe assembly is in place, please remove the urethane spacer (05-01100).

Step 5: Install the muffler/tail pipe assemblies with band clamps, utilizing the factory isolation mounts, do not fully tighten until tips have been centered in the bumper cut outs.

Step 6: Adjust for alignment and tighten all connections. Install cover plate using supplied spacers. Your installation is now complete. It is recommended to re-tighten all exhaust components after the first 50-100 miles.

NOTE:

- aFe recommends that the tailpipe be at least 1/2"-1" away from any body panels to avoid heat related body damage. **Tighten and secure.**
- IF additional clearance is needed, the soft aluminum heat shield can be reshaped at any points of contact.

Caution: Allow time for your vehicle to cool down prior to installation. When working on or under your vehicle proceed with caution. Exhaust systems reach high temperatures and may cause serious burns. Wear protective safety equipment; eye goggles and gloves to ensure a safe installation. **aFe recommends professional installation on our products.**



BMW 335i

2007-2009 L6-3.0L E90/92/93



+11

HORSEPOWER MAX GAIN
@ 5350 RPM

+10

lbs. X ft torque MAX GAIN
@ 5350 RPM



CLICK HERE TO WATCH VIDEO

PERFORMANCE EXHAUST

Features

- High performance
- 2.75" (70mm) mandrel-bent tubing
- Polished 304 SS construction
- Dual 3.50" (89mm) polished 304 SS tips
- Crossover pipe
- OE hangers

Benefits

- Increased flow
- Increased MPG
- Aggressive tone

Also Included

- aFe air Filter
P/N: 30-10156



Crossover Pipe
Equalizes pressure and
tunes the exhaust pulses

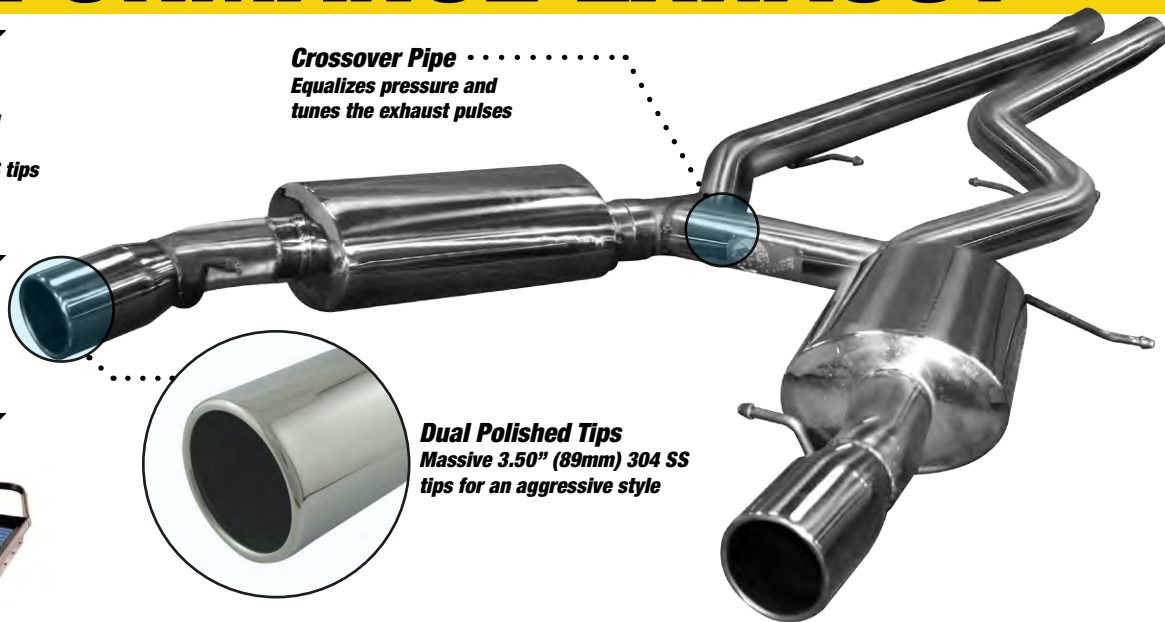

Dual Polished Tips
Massive 3.50" (89mm) 304 SS
tips for an aggressive style

Performance Data

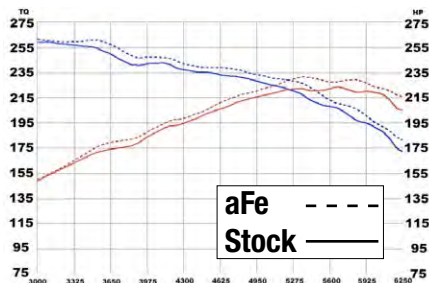

Assembly Layout

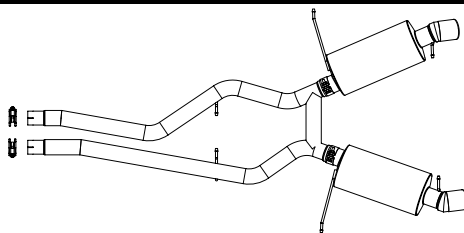

Installed



	P/N	Wheel Base	BOX SIZE	WEIGHT	INSTALL TIME	UPC	MSRP	JOBBER
	49-36301	108.7"	60" x 14" x 19"	65 lbs.	1.5 hours	80295949302	\$1493.75	\$1195.00

* Tested on 2009 BMW 335i with an OE air filter

advanced FLOW engineering

252 Granite St. Corona, CA 92879 • 951.493.7100 • FAX: 951.493.7177 • aFepower.com

P/N 40-12439
last updated 8-2009