



P/N
49-43008

**FORD EXCURSION
POWER STROKE
2000 - 2003 V8-7.3L (td)**

DIESEL EXHAUST



Features:

- High performance
- 4" mandrel-bent
- 409 SS
- Lowers EGT's
- OE style clamps and hangers

Benefits:

- +74% flow increase
- +18 lbs. x ft. torque
- +7HP

aFePower.com





Installation Instructions for: FORD POWER STROKE 2000-2003 V8-7.3L (td)

49-43008 (409SS) Turbo-Back (Off-Road)

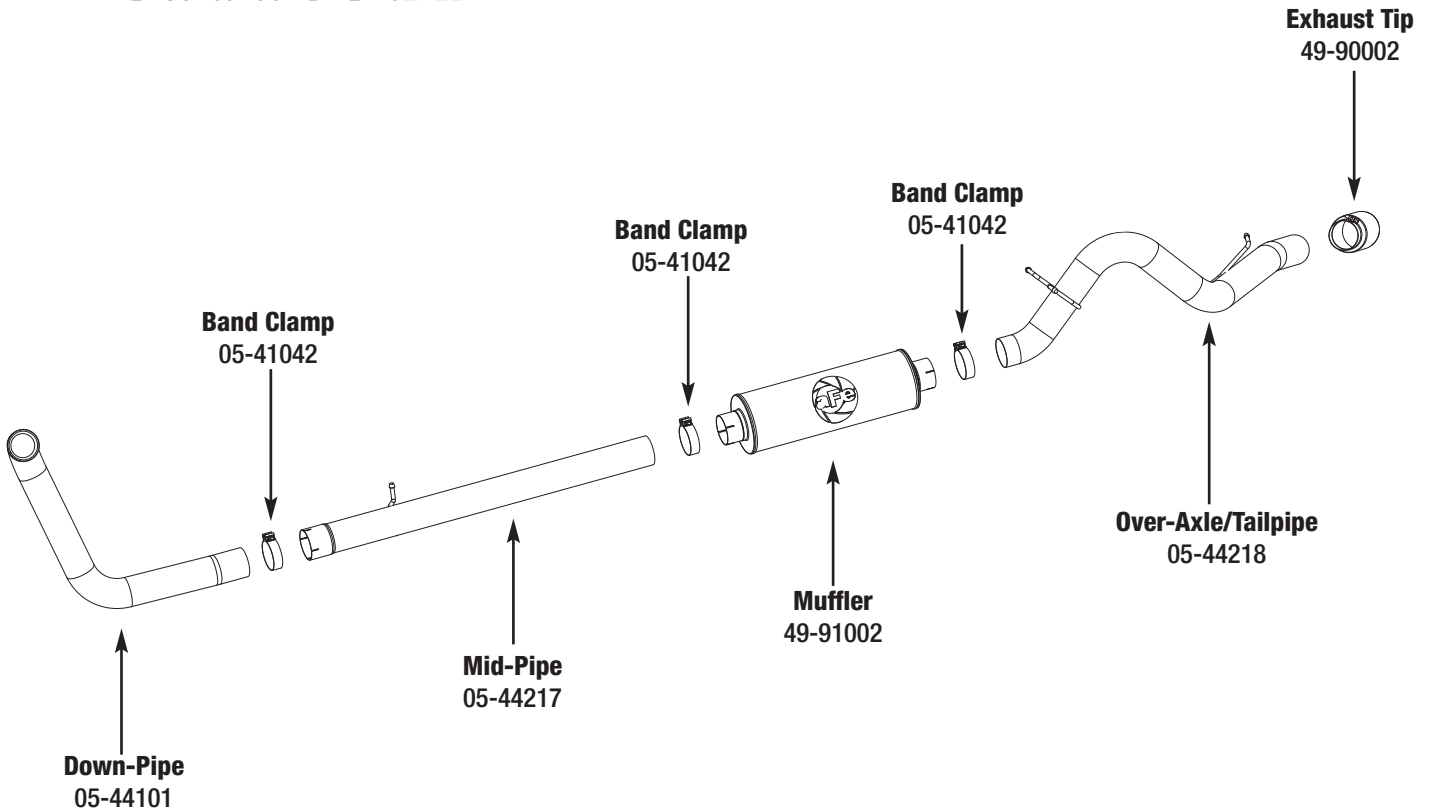

1: (Read Instructions prior to installation) Remove your stock exhaust from the rear of your truck working your way forward. Take caution not to damage the factory isolation mounts. If you want to remove the OE downpipe in one piece or without cutting, you must remove the transmission cross member and disconnect the dip-stick tube & sway bar end links. *It is recommended to not fully tighten the clamps until the entire system has been installed.*

2: For faster installation spread the pieces of the exhaust along side of your vehicle according to the diagram shown.

3: Install the down-pipe first, then install the mid-pipe. Fasten the clamp onto the slip joint.

4: Install the over-axle/tailpipe. Use the factory isolation mounts.

5: Now with the over-axle/tailpipe in place, fasten the muffler in between using the two clamps indicated.

6: Once you have assembled the exhaust, the rubber isolators should be angled forward slightly. Now make sure to tighten all clamps from front to rear. Install the exhaust tip and tighten. Your installation is now complete. It is recommended to re-tighten all parts after 50-100 miles.

NOTE:

- aFe recommends that the tailpipe be at least 1/2"-1" away from any body panels to avoid heat related body damage. **Tighten and secure.**

Caution: Allow time for your vehicle to cool down prior to installation. When working on or under your vehicle proceed with caution. Exhaust systems reach high temperatures and may cause serious burns. Wear protective safety equipment; eye goggles and gloves to ensure a safe installation. **aFe recommends professional installation on our products.**