



INSTALLATION INSTRUCTIONS

MAKE: FORD
MODEL: POWER STROKE
YEAR: 2008-2010
ENGINE: V8-6.4L (td)
WHEELBASE: 156" to 172"

4" Turbo Ball Socket Down Pipe
49-43025 (409SS)

THIS PART IS FOR RACE USE ONLY

This is a "Race Only" Product Used solely for Competition. Its use is limited to closed-course and open-course racing that is formally sanctioned by a recognized racing organization. Any other use, including recreational off-road use, could be in violation of local, state and federal laws.

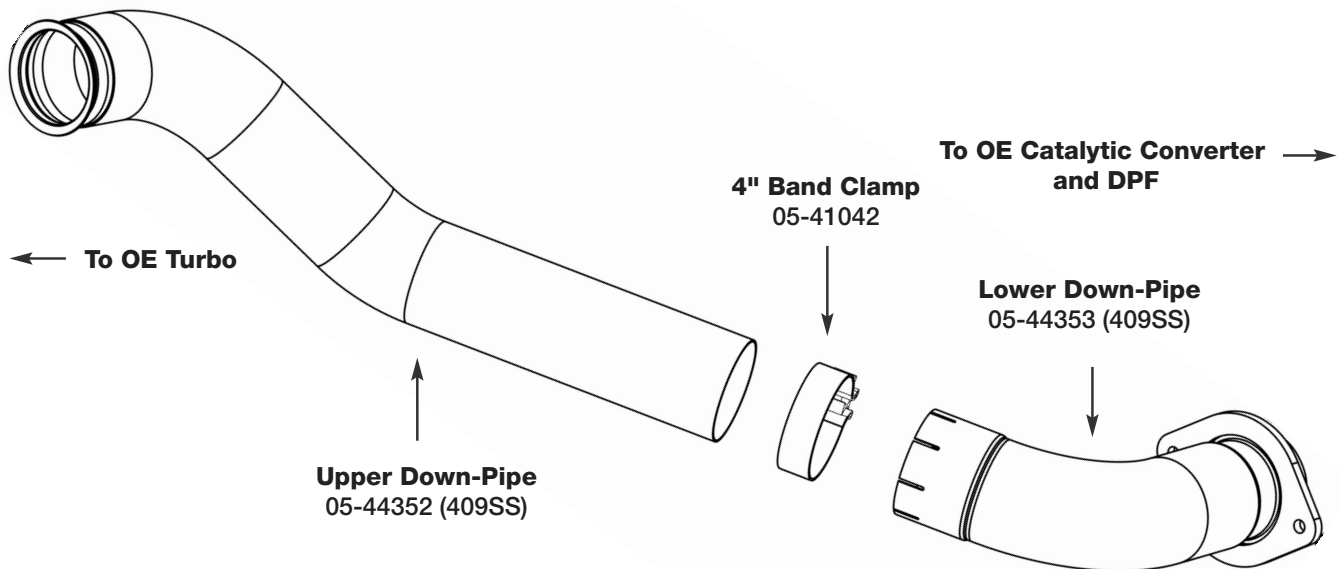

Step 1: (Read Instructions prior to installation) Remove your stock downpipe from the truck working your way forward. *It is recommended to not fully tighten the clamps until the entire system has been installed.*

Step 2: Removal of the OE downpipe will require cutting the downpipe or raising the cab off its mounts.

Step 3: Install the upper downpipe first, then install the lower downpipe. Connect the lower downpipe to the OE catalytic converter. Fasten the clamp onto the slip joint.

Step 4: Now make sure to tighten all clamps from front to rear.

Step 5: Your installation is now complete, it is recommended to re-tighten all parts after 50-100 miles.

NOTE:

- aFe recommends that the downpipe be away from any body panels to avoid heat related body damage. **Tighten and secure.**

Caution: Allow time for your vehicle to cool down prior to installation. When working on or under your vehicle proceed with caution. Exhaust systems reach high temperatures and may cause serious burns. Wear protective safety equipment; eye goggles and gloves to ensure a safe installation. **aFe recommends professional installation on our products.**