

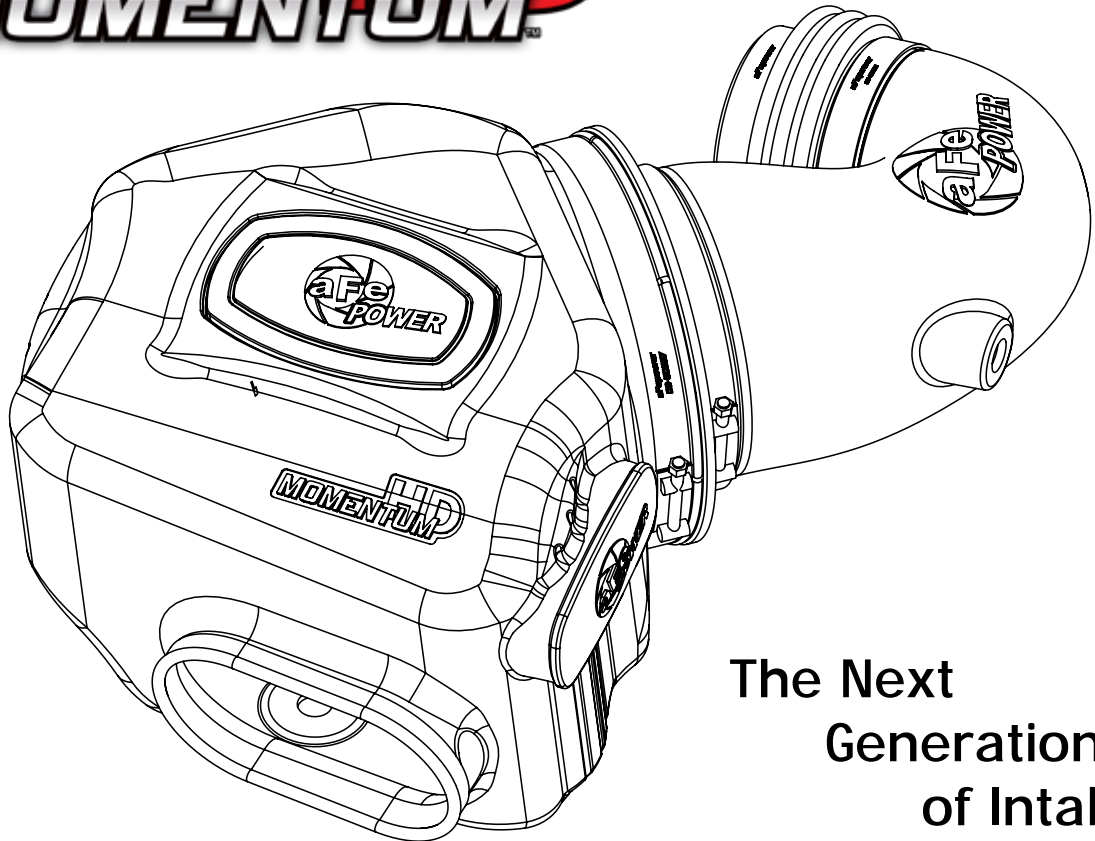

MOMENTUM^{HD}



The Next
Generation
of Intakes

advanced FLOW engineering Momentum Air Intake

Instruction Manual P/N: 51-72001-E

Make: **Dodge** Model: **RAM 2500 Heavy Duty** Year: **1994-2002** Engine: **L6-5.9L (td) Cummins**
Make: **Dodge** Model: **RAM 3500 Heavy Duty** Year: **1994-2002** Engine: **L6-5.9L (td) Cummins**



- Please read the entire instruction manual before proceeding.
- Ensure all components listed are present.
- If you are missing any of the components, call customer support at 951-493-7100 or e-mail at tech@afepower.com.
- Ensure you have all necessary tools before proceeding.
- Do not attempt to work on your vehicle when the engine is hot.
- Disconnect the negative battery terminal before proceeding.
- Retain factory parts for future use.

Label	Qty.	Description	Part Number
A	1	Air Filter (Pro DRY S)	21-91059
B	1	Housing	05-72001B2-A
C	1	Tube	05-72001B1
D	1	Grommet	03-50033
E	1	Cap	03-50103
F	1	Clamp, #064	03-50006
G	1	Coupling	05-01373
H	1	Seal Trim (18")	05-00072
I	1	Clamp, #072	03-50010
J	1	Plug	05-01202
K	1	Clamp (4-3/4" - 5")	03-50261
L	1	12oz. Cleaner Spray	90-10011

Warranty Information available at: <https://afepower.com/contact#warranty>

Installation will require the following tools:
5/16" Nut driver & 10mm Nut driver

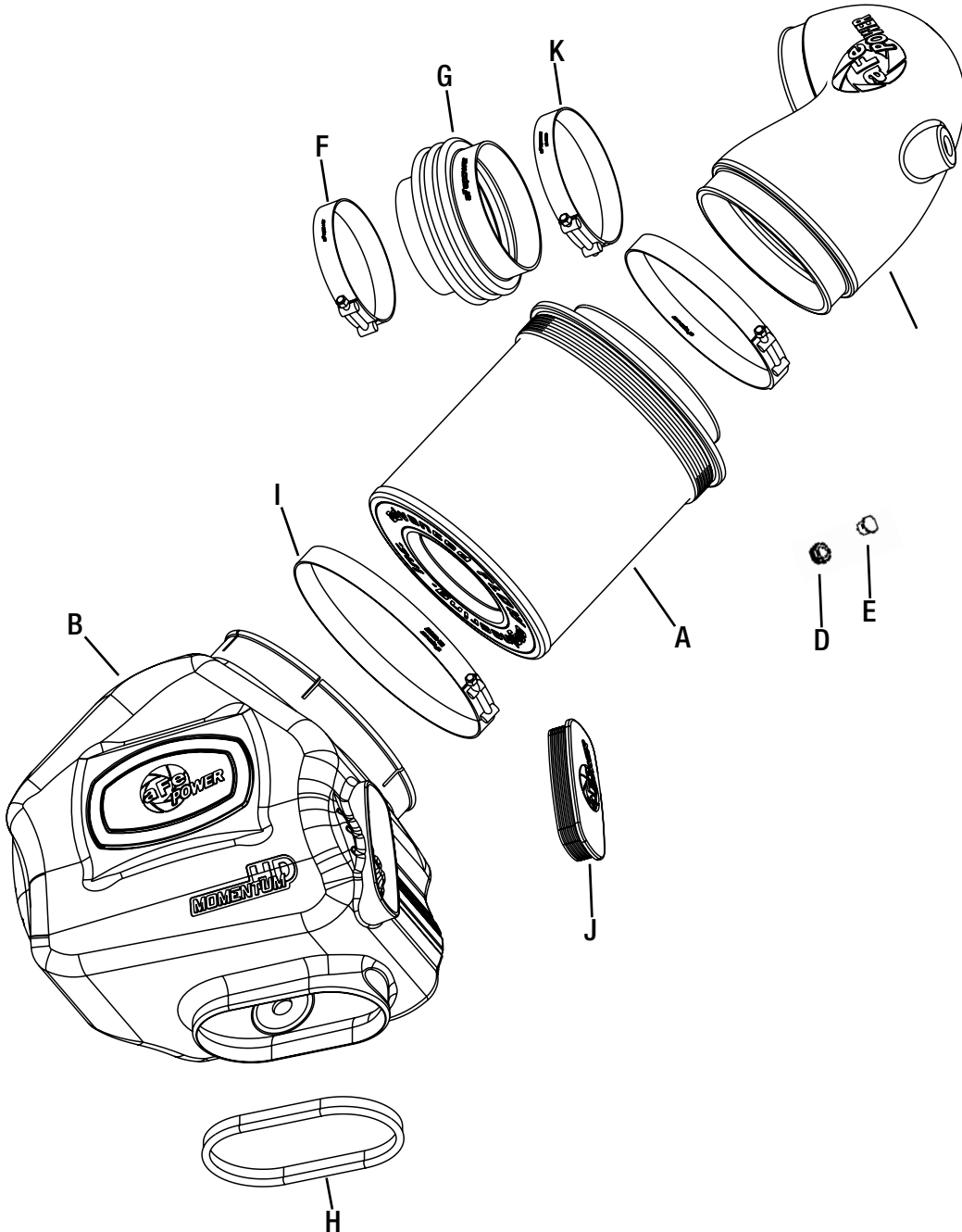



Figure A

Refer to Figure A for step 1

Step 1: Use a 5/16" nut driver to loosen the OE clamps (1) at the turbo and the air box. Remove the OE intake tube (2).



Figure B

Refer to Figure B for step 2

Step 2: Un-clip the upper half of the air box and remove upper half and air filter.



Refer to Figure C for step 3

Step 3: Remove the lower half of the air box (3) by pulling up to release air box from its mounting grommets (4).



Figure D

Refer to Figure D for step 4

Step 4: Make sure plastic inserts (5) are still on the mounting pins. If they pulled out and are stuck in the lower half of the air box grommet, remove them and insert them back on the mounting pins. Remove the plastic air duct (6) that goes through the fender if equipped.



Figure E

Refer to Figure E for step 5

Step 5: Remove all three grommets (7) from the lower half of the air box and install them onto the aFe air box.

MOMENTUM

INSTALL



Figure F

Refer to Figure F for step 14-15

Step 6: Install the trim seal (8) on the opening of the aFe air box.



Figure G

Refer to Figure G for steps 17-19

Step 7: Slide the aFe filter into the aFe housing. Install the larger clamps on the housing and filter.
Do not tighten at this time.



Figure F

Refer to Figure F for step 14-15

Step 8: Install the housing assembly into the vehicle by pushing down into the plastic pins.

Make sure pins are completely through the mounting grommets.



Figure G

Refer to Figure G for steps 17-19

Step 9: Install the aFe coupler (9) to the turbo using the smallest clamp (10) provided. Snug but do not tighten.



Figure F

Refer to Figure F for step 14-15

Step 10: Remove the filter minder and grommet (11) from the upper half of the stock air box. Install the grommet into the aFe intake tube and then push in the filter minder. If you choose not to use the filter minder, just plug off the hole with the provided grommet and cap.



Figure G

Refer to Figure G for steps 17-19

Step 11: Install the provided clamp (12) onto the coupler at the turbo then slide the aFe intake tube into the coupler. Connect the intake tube into the filter. Tighten all clamps with a 10mm nut driver.

**Figure F****Refer to Figure F for step 14-15**

Step 12: Use the provided plug (13) to close additional air inlet if you want to completely seal the air box. Check all the components are tight and secure. Your installation is now complete.

NOTE: Verify all connections are secured after 100-200 miles. Place enclosed CARB EO sticker on or near the intake system on a smooth/clean surface. EO identification label is required to pass the smog test inspection.



advanced FLOW engineering, inc.
252 Granite Street Corona, CA 92879
TEL: 951.493.7100 • TECH: 951.493.7134
E-Mail: Tech@aFepower.com