

Air Lift[™]
PERFORMANCE

Kit 75575
2010 Chevrolet
Camaro
front application



INSTALLATION GUIDE

For maximum effectiveness and safety, please read these instructions completely before proceeding with installation.

Failure to read these instructions can result in an incorrect installation.

TABLE OF CONTENTS

Introduction	2
Notation Explanation	2
Important Safety Notices	2
Installation Diagram	3
Hardware List	3
Tools List	3
Installing the Air Suspension	4
Preparing the Vehicle	4
Stock Strut Removal	4
Air Suspension Preparation/Installation	5
Aligning the Vehicle	8
Before Operating	8
Installation Checklist	9
Product Use, Maintenance and Servicing	10
Suggested Driving and Maximum Air Pressures	10
Maintaining and Operating	10
Troubleshooting Guide	9
Frequently Asked Questions	11
Tuning the Air Pressure	11
Checking for Leaks	11
Fixing Leaks	11
Warranty & Return Policy	13
Replacement Information	13
Contact Information	13

Introduction

The purpose of this publication is to assist with the installation, maintenance and troubleshooting of this Chevrolet Camaro Performance kit.

It is important to read and understand the entire installation guide before beginning installation or performing any maintenance, service or repair. The information includes a hardware list, tool list, step-by-step installation information, maintenance tips, safety information and a troubleshooting guide.

Air Lift Company reserves the right to make changes and improvements to its products and publications at any time. For the latest version of this manual, contact Air Lift Company at (800) 248-0892 or visit our website at www.airliftcompany.com.

NOTATION EXPLANATION

Hazard notations appear in various locations in this publication. Information which is highlighted by one of these notations must be observed to help minimize risk of personal injury or possible improper installation which may render the vehicle unsafe. Notes are used to help emphasize areas of procedural importance and provide helpful suggestions. The following definitions explain the use of these notations as they appear throughout this guide.



INDICATES IMMEDIATE HAZARDS WHICH WILL RESULT IN SEVERE PERSONAL INJURY OR DEATH.



INDICATES HAZARDS OR UNSAFE PRACTICES WHICH COULD RESULT IN SEVERE PERSONAL INJURY OR DEATH.



INDICATES HAZARDS OR UNSAFE PRACTICES WHICH COULD RESULT IN DAMAGE TO THE MACHINE OR MINOR PERSONAL INJURY.

NOTE

Indicates a procedure, practice or hint which is important to highlight.

IMPORTANT SAFETY NOTICES

The installation of this kit does not alter the Gross Vehicle Weight Rating (GVWR) or payload of the vehicle. Check your vehicle's owner's manual and do not exceed the maximum load listed for your vehicle.

Gross Vehicle Weight Rating: The maximum allowable weight of the fully loaded vehicle (including passengers and cargo). This number — along with other weight limits, as well as tire, rim size and inflation pressure data — is shown on the vehicle's Safety Compliance Certification Label.

Payload: The combined, maximum allowable weight of cargo and passengers that the vehicle is designed to carry. Payload is GVWR minus the Base Curb Weight.



DO NOT INFLATE AIR SPRINGS WHILE OFF OF THE VEHICLE. DAMAGE TO ASSEMBLY MAY RESULT AND VOID WARRANTY.



DO NOT WELD TO, OR MODIFY LIFESTYLE STRUTS/SHOCKS IN ANY WAY. DAMAGE TO UNIT MAY OCCUR AND WILL VOID WARRANTY.

Installation Diagram

NOTE:

- 1.) Remove Nyloc Nut and Spacer prior to installation.
- 2.) Install Leader Hose and Air Fitting with thread sealant and torque to 1-3/4 turns beyond hand tight.
- 3.) Torque 18015 Nyloc Nut to 41 Nm 30 ft./lbs.

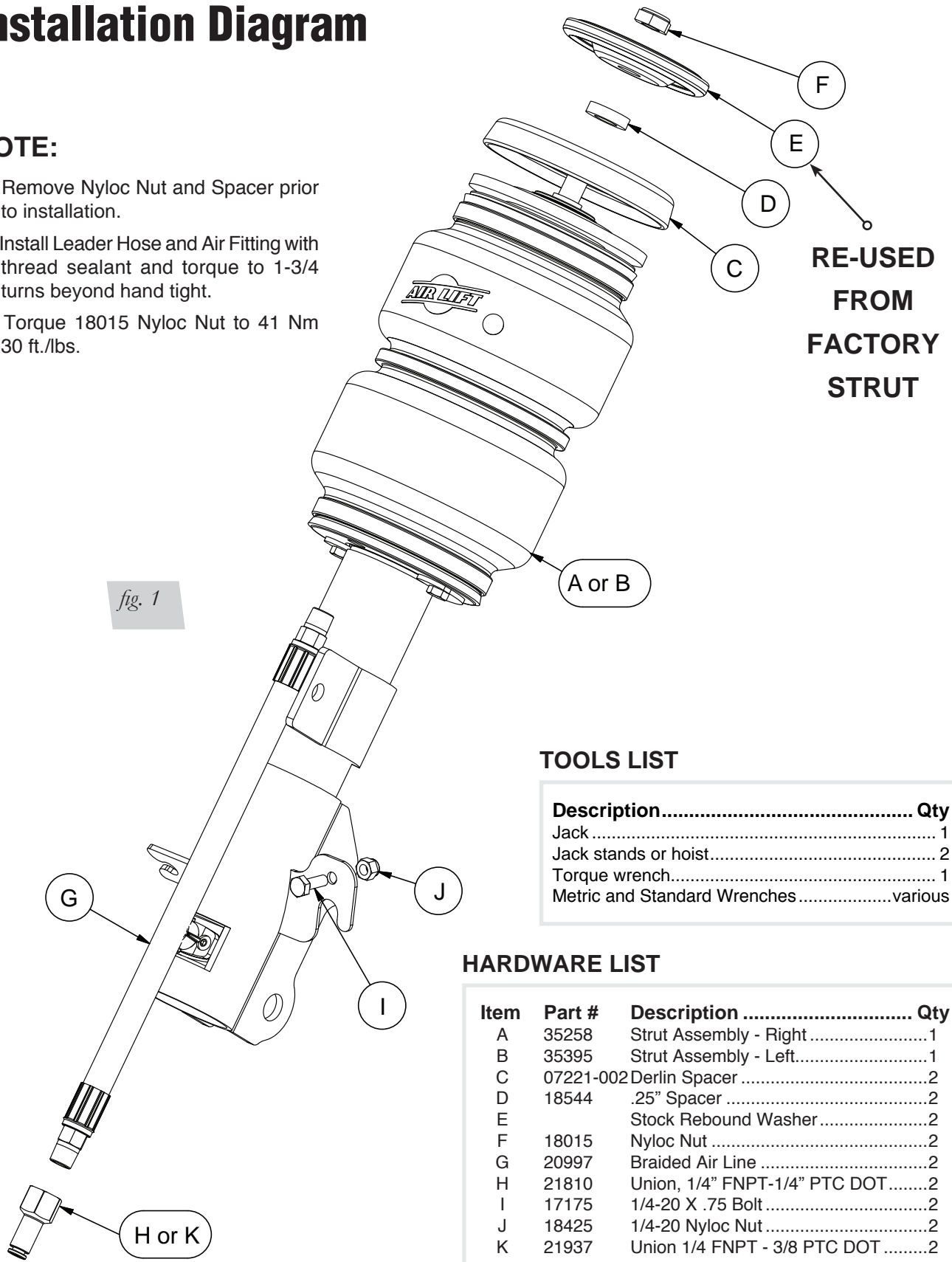

TOOLS LIST

Description	Qty
Jack	1
Jack stands or hoist	2
Torque wrench	1
Metric and Standard Wrenches	various

HARDWARE LIST

Item	Part #	Description	Qty
A	35258	Strut Assembly - Right	1
B	35395	Strut Assembly - Left	1
C	07221-002	Derlin Spacer	2
D	18544	.25" Spacer	2
E		Stock Rebound Washer	2
F	18015	Nyloc Nut	2
G	20997	Braided Air Line	2
H	21810	Union, 1/4" FNPT-1/4" PTC DOT	2
I	17175	1/4-20 X .75 Bolt	2
J	18425	1/4-20 Nyloc Nut	2
K	21937	Union 1/4 FNPT - 3/8 PTC DOT	2

STOP! Missing or damaged parts? Call Air Lift customer service at (800) 248-0892 for a replacement part.

Installing the Air Suspension

PREPARING THE VEHICLE

1. Support vehicle with jack stands or a hoist at approved lifting points.
2. Remove the front wheels

STOCK STRUT REMOVAL

1. Remove the bolt from the brake line tab and release brake line from the strut.
2. Unclip the sensor wire from the strut (fig. 2).
3. Unthread the stabilizer link nut from the strut and free the linkage from the strut (fig. 2).
4. Support the hub assembly

NOTE

Vehicle may come with camber adjuster set screws located on the top of the spindle. Ensure these are tight before removing the lower spindle bolts. This can be used to set a baseline camber but is not meant to supplement as a real alignment.

5. Unthread the spindle nuts and remove spindle bolts from the strut assembly (fig. 2).

Camber
set screw
location



fig. 2

6. From under the hood, remove the covers from the strut mount and unthread the nut from the strut rod. Remove the rebound washer and pull strut from the vehicle (fig. 3). **KEEP THE REBOUND WASHER!**

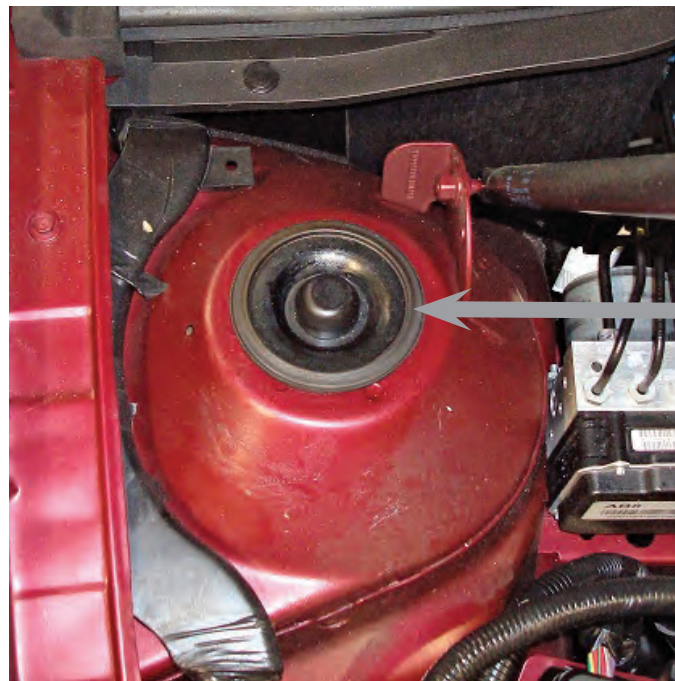

Rebound Washer

fig. 3

AIR SUSPENSION PREPARATION / INSTALLATION

1. Prior to installing the strut, apply Teflon™ tape or thread sealant to the threads of the air fitting and thread into the lower end cap of the air spring. Torque 1-3/4 turns beyond hand tight.
2. Remove the nyloc nut (F) and .25" spacer (D) from the top of the bellow-over-strut assembly (fig. 4). KEEP THESE PARTS!



fig. 4

3. Insert the strut assembly into the vehicle strut pocket. Fit the Derlin spacer (C) into the stock strut location. Add the .25" spacer (D) back onto the strut rod and apply the stock rebound washer (E) and nyloc nut (F) to the rod shown in the two images below (fig. 5a & 5b). Torque to 41 Nm (30 ft/lbs).

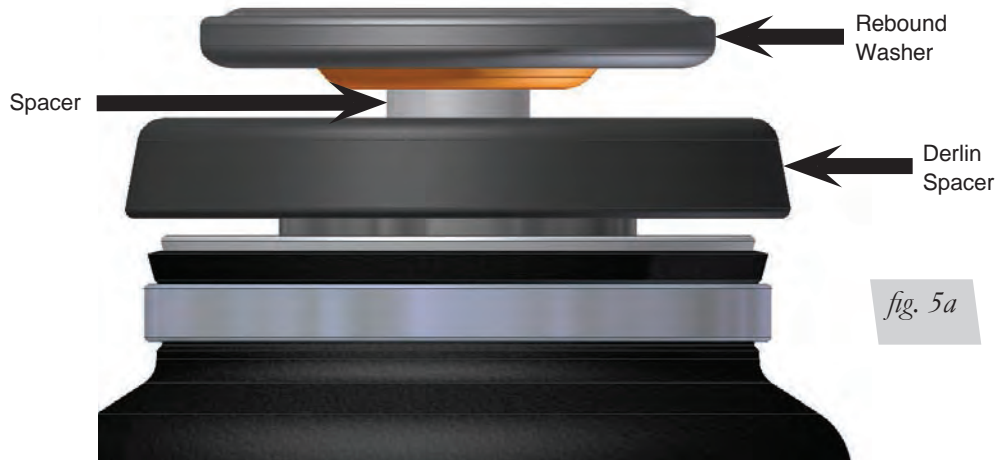

4. Install the factory spindle bolts and nuts. Torque to 129 Nm (95 ft/lbs).
5. Clip the sensor wire into the strut bracket.
6. Using the supplied bolts (I) and nuts (J), attach the brake line to the strut with attached brake line tab mounted on the backside of the strut bracket (fig. 6).



fig. 6

7. Reinstall the stabilizer end linkage. Torque to 45 Nm (33 ft/lbs).
8. Reinstall wheels, torque to 140Nm (100ft-lbs)

Torque Specifications		
Location	Nm	ft. lbs.
Strut spindle bolts	129	95
Stabilizer bar linkage	45	33
Rebound washer nyloc nut	41	30
Wheel lugs	140	100

Table 1

ALIGNING THE VEHICLE

1. Using the control system, set the vehicle height to the new custom ride height.
2. If the custom ride height is lower than stock, we recommend loosening all pivot points (bolts, nuts) on any control arm, strut arm or radius rod that contains bushings (fig. 7). Once they have been loosened, re-torque to stock specifications (fig. 8).

NOTE

It may be necessary to cycle the suspension to loosen the bushing up from its mount. This will help re-orient the bushing at its new position based on the custom ride height.

Before Operating

1. Some struts for this vehicle come with a nine-position damping dial for added adjustability (fig. 7). If not, proceed to 2.

Before driving your vehicle, set the new struts to their highest setting by turning the black dial on the shaft of the strut as far as it will go to the right (position 9).

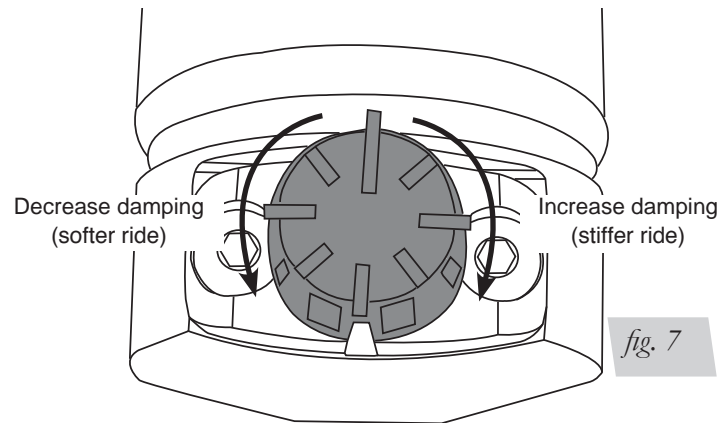

fig. 7

2. Next, completely deflate and reinflate the air bags 2-3 times. This procedure will purge any trapped air in the dampers and allow for maximum performance. For ride performance and the most versatility, Lifestyle recommends setting the strut dial (if equipped) to position 6 or higher.

CAUTION

MAKE SURE THE FRONT WHEELS ARE STRAIGHT WHEN DEFLATING AND REINFLATING AIR BAGS.

3. Inflate and deflate the system (do not exceed 125 PSI) to check for clearance or binding issues. With the air springs deflated, check clearances on everything so as not to pinch brake lines, vent tubes, etc. Clear lines if necessary.
4. Inflate the air springs to 75PSI - 90PSI and check all connections for leaks.
5. Air Lift part #27669 or #27671, AutoPilot V2 Air Management System, is highly recommended for this product.
6. Please continue by reading the Product Use, Maintenance and Servicing section.

INSTALLATION CHECKLIST

- Clearance test — Inflate the air springs to 75-90 PSI and make sure there is at least ½” clearance from anything that might rub against each sleeve. Be sure to check the tire, brake drum, frame, shock absorbers and brake cables.

- Leak test before road test — Inflate the air springs to 75PSI - 90PSI and check all connections for leaks. All leaks must be eliminated before the vehicle is road tested.

- Heat test — Be sure there is sufficient clearance from heat sources, at least 6” for air springs and air lines. If a heat shield was included in the kit, install it. If there is no heat shield, but one is required, call Air Lift customer service at (800) 248-0892.

- Fastener test — Recheck all bolts for proper torque.

- Road test — The vehicle should be road tested after the preceding tests. Inflate the springs to recommended driving pressures. Drive the vehicle 10 miles and recheck for clearance, loose fasteners and air leaks.

- Operating instructions — If professionally installed, the installer should review the operating instructions with the owner. Be sure to provide the owner with all of the paperwork that came with the kit.

Technician's Signature _____

Date _____

POST-INSTALLATION CHECKLIST

- Overnight leak down test — Recheck air pressure after the vehicle has been used for 24 hours. If the pressure has dropped more than 5 PSI, then there is a leak that must be fixed. Either fix the leak yourself or return to the installer for service.

- Air pressure requirements — I understand the air pressure requirements of my air spring system. Regardless of load, the air pressure should always be adjusted to maintain adequate ride height at all times while driving.

- Thirty day or 500 mile test — I understand that I must recheck the air spring system after 30 days or 500 miles, whichever comes first. If any part shows signs of rubbing or abrasion, the source should be identified and moved, if possible. If it is not possible to relocate the cause of the abrasion, the air spring may need to be remounted. If professionally installed, the installer should be consulted. Check all fasteners for tightness.

Product Use, Maintenance and Servicing

Suggested Driving Air Pressure	Maximum Air Pressure
45 PSI	125 PSI
FAILURE TO MAINTAIN ADEQUATE MINIMUM PRESSURE (OR PRESSURE PROPORTIONAL TO LOAD) WILL RESULT IN BOTTOMING OUT, OVER-EXTENSION OR RUBBING AGAINST ANOTHER COMPONENT AND WILL VOID THE WARRANTY.	

MAINTENANCE GUIDELINES

NOTE

By following these steps, vehicle owners will obtain the longest life and best results from their air spring.

1. Check the air pressure before driving.
2. Never inflate beyond 125 PSI.
3. If you develop an air leak in the system, use a soapy water solution to check all air line connections, before deflating and removing the spring.
4. When increasing load, always adjust the air pressure to maintain normal ride height. Increase or decrease pressure from the system as necessary to attain normal ride height for optimal ride and handling. Remember that loads carried behind the axle (including tongue loads) require more leveling force (pressure) than those carried directly over the axle.

CAUTION

FOR YOUR SAFETY AND TO PREVENT DAMAGE TO YOUR VEHICLE, DO NOT EXCEED MAXIMUM GROSS VEHICLE WEIGHT RATING (GVWR), AS INDICATED BY THE VEHICLE MANUFACTURER. ALTHOUGH YOUR AIR SPRINGS ARE RATED AT A MAXIMUM INFLATION PRESSURE OF 125 PSI, THE AIR PRESSURE ACTUALLY NEEDED IS DEPENDENT ON YOUR LOAD.

5. Always add air to the springs in small quantities, checking the pressure frequently. Sleeves require less air volume than a tire and inflate quickly.
6. Should it become necessary to raise the vehicle by the frame, make sure the control system is turned off before lifting.

Troubleshooting Guide

1. Leak test the air line connections, the threaded connection into the air spring, and all fittings in the control system.
2. Inspect the air lines to be sure none are pinched. Tie straps may be too tight. Loosen or replace the strap and replace leaking components.
3. Inspect the air line for holes and cracks. Replace as needed.
4. Look for a kink or fold in the air line. Reroute as needed.

If the preceding steps do not solve the problem, it is possibly caused by a failed air spring — either a factory defect or an operating problem. Please call Air Lift at (800) 248-0892 for assistance.

Frequently Asked Questions

Q. Will installing air springs increase the weight ratings of a vehicle?

No. Adding air springs will not change the weight ratings (GAWR, GCWR and/or GVWR) of a vehicle. Exceeding the GVWR is dangerous and voids the Air Lift warranty.

Q. How long should air springs last?

If the air springs are properly installed and maintained they can last indefinitely.

Q. Will raising the vehicle on a hoist for service work damage the air springs?

No. The vehicle can be lifted on a hoist for short-term service work such as tire rotation or oil changes. However, if the vehicle will be on the hoist for a prolonged period of time, support the axle with jack stands in order to take the tension off of the air springs.

Tuning the Air Pressure

Pressure determination comes down to three things — level vehicle, ride comfort, and stability.

1. Level vehicle

If the vehicle's headlights are shining into the trees or the vehicle is leaning to one side, then it is not level. Raise the air pressure to correct either of these problems and level the vehicle.

2. Ride comfort

If the vehicle has a rough or harsh ride it may be due to either too much pressure or not enough. Try different pressures to determine the best ride comfort. See Air Lift suggested driving air pressure.

3. Stability

Stability translates into safety and should be the priority, meaning the driver may need to sacrifice a perfectly level and comfortable ride. Stability issues include roll control, bounce, dive during braking and sponginess. Tuning out these problems usually requires additional air pressure, strut damping, or both.

Checking for leaks

1. Inflate the air spring to 80 PSI.
2. Spray all connections and the inflation valves with a solution of 1/5 liquid dish soap and 4/5 water. Spot leaks easily by looking for bubbles in the soapy water.
3. After the test, deflate the springs to the minimum pressure required to restore the system to normal ride height.
4. Check the air pressure again after 24 hours. A 2 - 4 PSI loss after initial installation is normal. Retest for leaks if the loss is more than 5 lbs.

Fixing Leaks

1. If there is a problem with a swivel fitting:
 - a. Check the air line connection by deflating the spring and removing the line by pulling the collar against the fitting and pulling firmly on the air line. Trim 1" off the end of the air line. Be sure the cut is clean and square (see fig. 8). Reinsert the air line into the push-to-connect fitting.

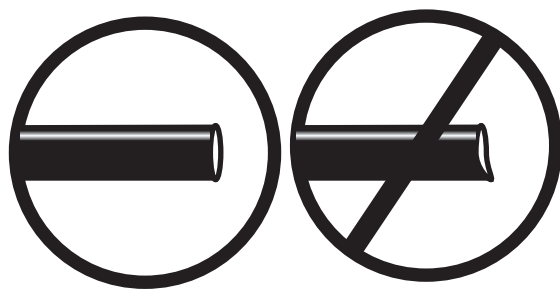
*fig. 8*

- b. Check the threaded connection by tightening the swivel fitting another $\frac{1}{2}$ turn. If it still leaks, deflate the air spring, remove the fitting, and re-coat the threads with thread sealant. Reinstall by hand tightening as much as possible and then use a wrench for an additional two turns.
2. If the preceding steps have not resolved the problem, call Air Lift customer service at (800) 248-0892.

Warranty and Returns Policy

Air Lift Company warrants its performance products for one year to the original purchaser against manufacturing defects one year from the date of purchase when used on cars and trucks as specified under normal operating conditions. The warranty does not apply to products that have been improperly applied, improperly installed, or which have not been maintained in accordance with installation instructions furnished with all products. The consumer will be responsible for removing (labor charges) the defective product from the vehicle and returning it, transportation costs prepaid, to the dealer from which it was purchased or to Air Lift Company for verification.

Air Lift will repair or replace, at its option, defective products or components. A minimum \$10.00 shipping and handling charge will apply to all warranty claims. Before returning any defective product, you must call Air Lift at (800) 248-0892 in the U.S. and Canada (elsewhere, (517) 322-2144) for a Returned Materials Authorization (RMA) number. Returns to Air Lift can be sent to: Air Lift Company • 2727 Snow Road • Lansing, MI • 48917.

Product failures resulting from abnormal use or misuse are excluded from this warranty. The loss of use of the product, loss of time, inconvenience, commercial loss or consequential damages is not covered. The consumer is responsible for installation/reinstallation (labor charges) of the product. Air Lift Company reserves the right to change the design of any product without assuming any obligation to modify any product previously manufactured.

This warranty gives you specific legal rights and you may also have other rights that may vary from state-to-state. Some states do not allow limitations on how long an implied warranty lasts or allow the exclusion or limitation of incidental or consequential damages. The above limitation or exclusion may not apply to you. There are no warranties, expressed or implied including any implied warranties of merchantability and fitness, which extend beyond this warranty period. There are no warranties that extend beyond the description on the face hereof. Seller disclaims the implied warranty of merchantability. (Dated proof of purchase required.)

Replacement Information

If you need replacement parts, contact the local dealer or call Air Lift customer service at (800) 248-0892. Most parts are immediately available and can be shipped the same day.

Contact Air Lift Company customer service at (800) 248-0892 first if:

- Parts are missing from the kit.
- Broken or defective parts in the kit.
- Need technical assistance on installation or operation.
- Wrong parts in the kit.
- Have a warranty claim or question.

Contact the retailer where the kit was purchased:

- If it is necessary to return or exchange the kit for any reason.
- If there is a problem with shipping if shipped from the retailer.
- If there is a problem with the price.

Contact Information

If you have any questions, comments or need technical assistance contact our customer service department by calling (800) 248-0892, Monday through Friday, 8 a.m. to 7 p.m. Eastern Time. For calls from outside the USA or Canada, our local number is (517) 322-2144. You may also contact customer service anytime by e-mail at techsupport@airliftperformance.com.

For inquiries by mail, our address is PO Box 80167, Lansing, MI 48908-0167. Our shipping address for returns is 2727 Snow Road, Lansing, MI 48917.

You may also contact our sales team anytime by e-mail at sales@airliftperformance.com or on the web at www.airliftperformance.com.

Need Help?

Contact our customer service department by calling (800) 248-0892, Monday through Friday, 8 a.m. to 7 p.m. Eastern Time. For calls from outside the USA or Canada, our local number is (517) 322-2144.



Thank you for purchasing Air Lift Performance products!

Air Lift Company • 2727 Snow Road • Lansing, MI 48917 or PO Box 80167 • Lansing, MI 48908-0167
Toll Free (800) 248-0892 • Local (517) 322-2144 • Fax (517) 322-0240 • www.airliftperformance.com

Printed in
the USA

Air Lift[™]
PERFORMANCE

Kit 75675
2010 Chevrolet Camaro
rear application



INSTALLATION GUIDE

For maximum effectiveness and safety, please read these instructions completely before proceeding with installation.

Failure to read these instructions can result in an incorrect installation.

TABLE OF CONTENTS

Introduction	2
Notation Explanation	2
Important Safety Notices	2
Installation Diagram	3
Hardware List	3
Tools List	3
Installing the Air Suspension	4
Preparing the Vehicle	4
Stock Shock Removal	4
Air Suspension Installation	5
Aligning the Vehicle	6
Before Operating	7
Installation Checklist	8
Product Use, Maintenance and Servicing	9
Suggested Driving and Maximum Air Pressures	9
Maintaining and Operating	9
Troubleshooting Guide	9
Frequently Asked Questions	10
Tuning the Air Pressure	10
Checking for Leaks	10
Fixing Leaks	10
Warranty & Returns Policy	12
Replacement Information	12
Contact Information	12
Template	13



Introduction

The purpose of this publication is to assist with the installation, maintenance and troubleshooting of this Chevrolet Camaro Lifestyle kit.

It is important to read and understand the entire installation guide before beginning installation or performing any maintenance, service or repair. The information includes a hardware list, tool list, step-by-step installation information, maintenance tips, safety information and a troubleshooting guide.

Air Lift Company reserves the right to make changes and improvements to its products and publications at any time. For the latest version of this manual, contact Air Lift Company at (800) 248-0892 or visit our website at www.airliftcompany.com.

NOTATION EXPLANATION

Hazard notations appear in various locations in this publication. Information which is highlighted by one of these notations must be observed to help minimize risk of personal injury or possible improper installation which may render the vehicle unsafe. Notes are used to help emphasize areas of procedural importance and provide helpful suggestions. The following definitions explain the use of these notations as they appear throughout this guide.

DANGER

INDICATES IMMEDIATE HAZARDS WHICH WILL RESULT IN SEVERE PERSONAL INJURY OR DEATH.

WARNING

INDICATES HAZARDS OR UNSAFE PRACTICES WHICH COULD RESULT IN SEVERE PERSONAL INJURY OR DEATH.

CAUTION

INDICATES HAZARDS OR UNSAFE PRACTICES WHICH COULD RESULT IN DAMAGE TO THE MACHINE OR MINOR PERSONAL INJURY.

NOTE

Indicates a procedure, practice or hint which is important to highlight.

IMPORTANT SAFETY NOTICES

The installation of this kit does not alter the Gross Vehicle Weight Rating (GVWR) or payload of the vehicle. Check your vehicle's owner's manual and do not exceed the maximum load listed for your vehicle.

Gross Vehicle Weight Rating: The maximum allowable weight of the fully loaded vehicle (including passengers and cargo). This number — along with other weight limits, as well as tire, rim size and inflation pressure data — is shown on the vehicle's Safety Compliance Certification Label.

Payload: The combined, maximum allowable weight of cargo and passengers that the vehicle is designed to carry. Payload is GVWR minus the Base Curb Weight.

WARNING

DO NOT INFLATE AIR SPRINGS WHILE OFF OF THE VEHICLE. DAMAGE TO ASSEMBLY MAY RESULT AND VOID WARRANTY.

CAUTION

DO NOT WELD TO, OR MODIFY LIFESTYLE STRUTS/SHOCKS IN ANY WAY. DAMAGE TO UNIT MAY OCCUR AND WILL VOID WARRANTY.

Installation Diagram

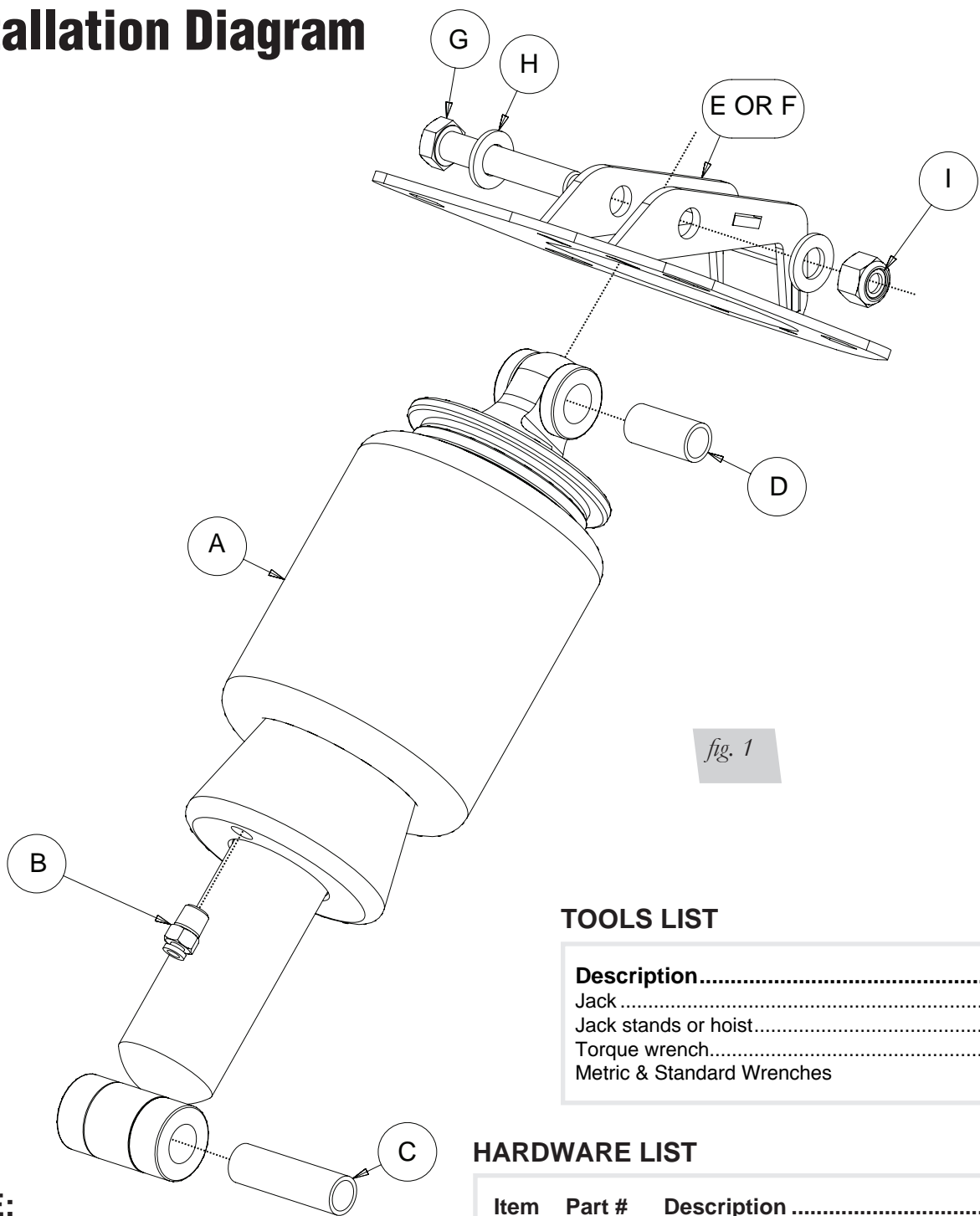

NOTE:

- 1.) Air fitting to be installed with thread sealant and torqued 1-3/4 turns beyond hand tight.
- 2.) Lubricate sleeves with grease at mating interfaces.
- 3.) Align upper bracket uprights opposite air-port.
- 4.) Torque bolt to 125NM (90 ft/lbs).

TOOLS LIST

Description.....	Qty
Jack	1
Jack stands or hoist.....	2
Torque wrench.....	1
Metric & Standard Wrenches	

HARDWARE LIST

Item	Part #	Description	Qty
A	35396	Shock Assembly Rear.....	2
B	21807	1/4" MNPT X 1/4 PTC Straight.....	2
C	11035	Bushing, Lower	2
D	11034	Bushing, Upper	2
E	07212	Upper Bracket, Right Rear.....	1
F	07337	Upper Bracket, Left Rear	1
G	17381	M14-2 X 80 Bolt	2
H	18571	M14 Flat Washer.....	4
I	18553	M14 X 2 Nyloc Nut.....	2



Missing or damaged parts? Call Air Lift customer service at (800) 248-0892 for a replacement part.

Installing the Air Suspension

PREPARING THE VEHICLE

1. Support vehicle with jack stands or a hoist at approved lifting points.
2. Remove the rear wheels

STOCK SHOCK REMOVAL

1. Unbolt the four upper mount bolts from the chassis.
2. Loosen and remove the lower shock mounting nut from the control arm (fig. 2).

fig. 2

CAUTION

STABILIZER BAR MAY BE UNDER TENSION.

3. Unthread the stabilizer bar end link from the control arm (fig. 3).

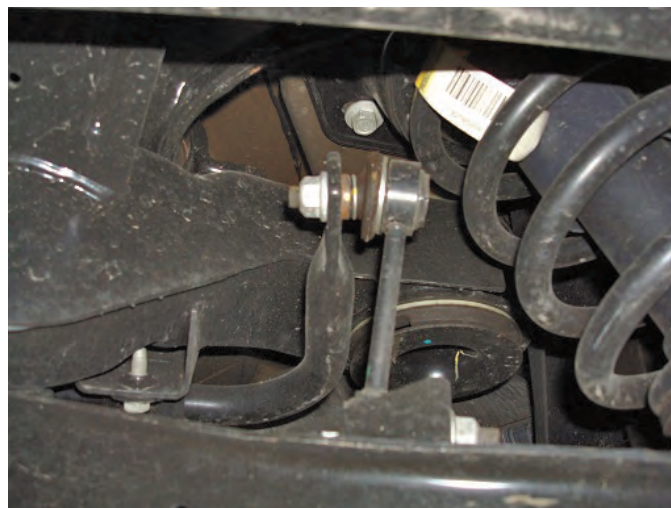
fig. 3

CAUTION

SHOCK ASSEMBLY IS UNDER TENSION

4. Securely support the lower control arm. Unbolt and remove the control arm-to-spindle bolt. Cautiously lower the control arm until shock is fully extended. Remove shock assembly from the vehicle (fig. 2).
5. Loosely reattach the lower control arm to the spindle.

AIR SUSPENSION INSTALLATION

1. Using the template at the back of this manual: first place the corresponding upper bracket on the template to verify the template size is correct. Cut out the supplied template. Apply template to the upper shock body mount and attach with previously removed bolts. Clearly mark the chassis area to be cut and remove the template for use on the other side. Cut metal to the template (fig. 4). Keep in mind template needs to be flipped between left and right. Take the supplied brackets (E and F) and verify fitment by bolting in place before proceeding. Remove all burrs and sharp edges from worked area. Treat the worked area with paint to prevent oxidation.



fig. 4

2. Prior to installing the shock, apply Teflon tape or thread sealant to the threads of the air fitting (B) and thread into the lower end cap of the air spring. Torque 1-3/4 turns beyond hand tight.
3. Lubricate the bushings inner diameter and outer diameter of the corresponding sleeve (C and D). Press the sleeves into the bushing eye mounts.
4. Attach the upper bracket to the upper eye so that the bracket “points” away from the air fitting. This air fitting must be inboard of the vehicle (fig. 5).

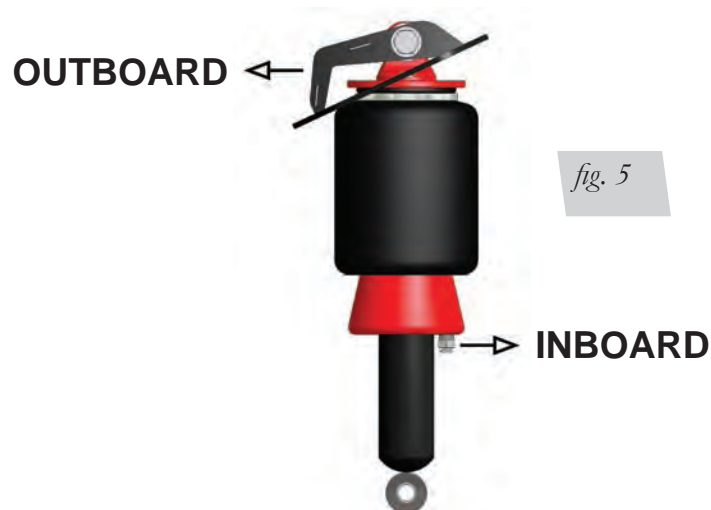

fig. 5

5. Align the bushing sleeve with the bracket hole and fasten together using the supplied bolt (G), washers (H) and nyloc nut (I). Torque to 125Nm (90 ft-lbs). The shock should freely articulate within the bracket.
6. Insert the new shock assembly and loosely bolt the upper bracket into place.
7. Align and loosely fasten the lower shock eye to the lower control arm.
8. Compress the suspension approximately halfway. Shift the upper bracket if necessary to prevent binding and then torque the mount bolts to 47 Nm (35 ft-lbs)
9. Reattach the stabilizer linkage and torque to 45Nm (33ft-lbs).

NOTE

Some after market stabilizer bars can slide side to side because the bar bushings are not locked to the bar. This could potentially damage the air spring assembly. Bar Clamps are available from some manufacturers and is highly recommended.

10. Reattach the wheels. Torque to 140Nm (100ft-lbs).
11. Lower vehicle to ride height and torque the lower shock bushing bolt to 88Nm (65ft-lbs). Also torque the control arm to spindle bolt to 47Nm (35ft-lbs).

Torque Specifications		
Location	Nm	ft. lbs.
Shock upper eye to bracket	125	90
Upper bracket to chassis	47	35
Lower shock mount to control arm	88	65
Lower control arm to spindle	47	35
Stabilizer end link	45	33
Wheel lugs	140	100

Table 1

ALIGNING THE VEHICLE

1. Using the control system, set the vehicle height to the new custom ride height.
2. If the custom ride height is lower than stock, we recommend loosening all pivot points (bolts, nuts) on any control arm, strut arm or radius rod that contains bushings. Once they have been loosened, re-torque to stock specifications (Table 1).

NOTE

It may be necessary to cycle the suspension to loosen the bushing up from its mount. This will help re-orient the bushing at its new position based on the custom ride height.

Before Operating

1. Some struts for this vehicle come with a nine-position damping dial for added adjustability (fig. 6). If not, proceed to 2.

NOTE

Before driving your vehicle, set the new struts to their highest setting by turning the black dial on the shaft of the strut as far as it will go to the right (position 9).

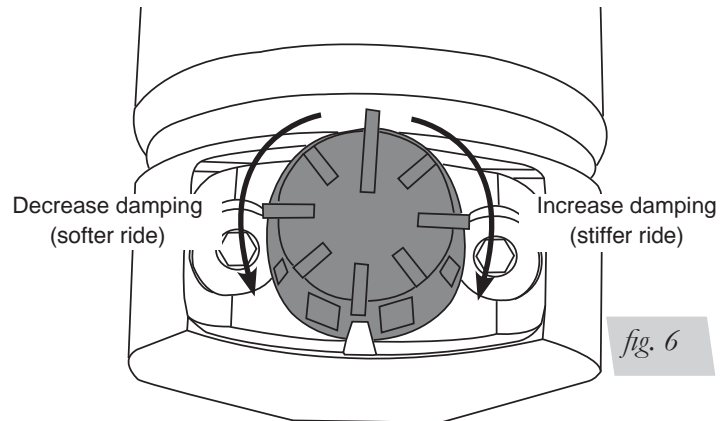

2. Next, completely deflate and reinflate the air bags 2-3 times. This procedure will purge any trapped air in the dampers and allow for maximum performance. For ride performance and the most versatility, Lifestyle recommends setting the strut dial (if equipped) to position 6 or higher.

CAUTION

MAKE SURE THE FRONT WHEELS ARE STRAIGHT WHEN DEFLATING AND REINFLATING AIR BAGS.

3. Inflate and deflate the system (do not exceed 125 PSI) to check for clearance or binding issues. With the air springs deflated, check clearances on everything so as not to pinch brake lines, vent tubes, etc. Clear lines if necessary.
4. Inflate the air springs to 75PSI - 90PSI and check all connections for leaks.
5. Air Lift part #27669 or #27671, AutoPilot V2 Air Management System, is highly recommended for this product.
6. Please continue by reading the Product Use, Maintenance and Servicing section.

INSTALLATION CHECKLIST

- Clearance test — Inflate the air springs to 75-90 PSI and make sure there is at least ½” clearance from anything that might rub against each sleeve. Be sure to check the tire, brake drum, frame, shock absorbers and brake cables.

- Leak test before road test — Inflate the air springs to 75PSI - 90PSI and check all connections for leaks. All leaks must be eliminated before the vehicle is road tested.

- Heat test — Be sure there is sufficient clearance from heat sources, at least 6” for air springs and air lines. If a heat shield was included in the kit, install it. If there is no heat shield, but one is required, call Air Lift customer service at (800) 248-0892.

- Fastener test — Recheck all bolts for proper torque.

- Road test — The vehicle should be road tested after the preceding tests. Inflate the springs to recommended driving pressures. Drive the vehicle 10 miles and recheck for clearance, loose fasteners and air leaks.

- Operating instructions — If professionally installed, the installer should review the operating instructions with the owner. Be sure to provide the owner with all of the paperwork that came with the kit.

Technician's Signature _____

Date _____

POST-INSTALLATION CHECKLIST

- Overnight leak down test — Recheck air pressure after the vehicle has been used for 24 hours. If the pressure has dropped more than 5 PSI, then there is a leak that must be fixed. Either fix the leak yourself or return to the installer for service.

- Air pressure requirements — I understand the air pressure requirements of my air spring system. Regardless of load, the air pressure should always be adjusted to maintain adequate ride height at all times while driving.

- Thirty day or 500 mile test — I understand that I must recheck the air spring system after 30 days or 500 miles, whichever comes first. If any part shows signs of rubbing or abrasion, the source should be identified and moved, if possible. If it is not possible to relocate the cause of the abrasion, the air spring may need to be remounted. If professionally installed, the installer should be consulted. Check all fasteners for tightness.

Product Use, Maintenance and Servicing

Suggested Driving Air Pressure	Maximum Air Pressure
85 PSI	125 PSI
FAILURE TO MAINTAIN ADEQUATE MINIMUM PRESSURE (OR PRESSURE PROPORTIONAL TO LOAD) WILL RESULT IN BOTTOMING OUT, OVER-EXTENSION OR RUBBING AGAINST ANOTHER COMPONENT AND WILL VOID THE WARRANTY.	

MAINTENANCE GUIDELINES

NOTE

By following these steps, vehicle owners will obtain the longest life and best results from their air spring.

1. Check the air pressure before driving.
2. Never inflate beyond 125 PSI.
3. If you develop an air leak in the system, use a soapy water solution to check all air line connections, before deflating and removing the spring.
4. When increasing load, always adjust the air pressure to maintain normal ride height. Increase or decrease pressure from the system as necessary to attain normal ride height for optimal ride and handling. Remember that loads carried behind the axle (including tongue loads) require more leveling force (pressure) than those carried directly over the axle.

CAUTION

FOR YOUR SAFETY AND TO PREVENT DAMAGE TO YOUR VEHICLE, DO NOT EXCEED MAXIMUM GROSS VEHICLE WEIGHT RATING (GVWR), AS INDICATED BY THE VEHICLE MANUFACTURER. ALTHOUGH YOUR AIR SPRINGS ARE RATED AT A MAXIMUM INFLATION PRESSURE OF 125 PSI, THE AIR PRESSURE ACTUALLY NEEDED IS DEPENDENT ON YOUR LOAD.

5. Always add air to the springs in small quantities, checking the pressure frequently. Sleeves require less air volume than a tire and inflate quickly.
6. Should it become necessary to raise the vehicle by the frame, make sure the control system is turned off before lifting.

Troubleshooting Guide

1. Leak test the air line connections, the threaded connection into the air spring, and all fittings in the control system.
2. Inspect the air lines to be sure none are pinched. Tie straps may be too tight. Loosen or replace the strap and replace leaking components.
3. Inspect the air line for holes and cracks. Replace as needed.
4. Look for a kink or fold in the air line. Reroute as needed.

If the preceding steps do not solve the problem, it is possibly caused by a failed air spring — either a factory defect or an operating problem. Please call Air Lift at (800) 248-0892 for assistance.

Frequently Asked Questions

Q. Will installing air springs increase the weight ratings of a vehicle?

No. Adding air springs will not change the weight ratings (GAWR, GCWR and/or GVWR) of a vehicle. Exceeding the GVWR is dangerous and voids the Air Lift warranty.

Q. How long should air springs last?

If the air springs are properly installed and maintained they can last indefinitely.

Q. Will raising the vehicle on a hoist for service work damage the air springs?

No. The vehicle can be lifted on a hoist for short-term service work such as tire rotation or oil changes. However, if the vehicle will be on the hoist for a prolonged period of time, support the axle with jack stands in order to take the tension off of the air springs.

Tuning the Air Pressure

Pressure determination comes down to three things — level vehicle, ride comfort, and stability.

1. Level vehicle

If the vehicle's headlights are shining into the trees or the vehicle is leaning to one side, then it is not level. Raise the air pressure to correct either of these problems and level the vehicle.

2. Ride comfort

If the vehicle has a rough or harsh ride it may be due to either too much pressure or not enough. Try different pressures to determine the best ride comfort. See Air Lift suggested driving air pressure.

3. Stability

Stability translates into safety and should be the priority, meaning the driver may need to sacrifice a perfectly level and comfortable ride. Stability issues include roll control, bounce, dive during braking and sponginess. Tuning out these problems usually requires additional air pressure, strut damping, or both.

Checking for leaks

1. Inflate the air spring to 80 PSI.
2. Spray all connections and the inflation valves with a solution of 1/5 liquid dish soap and 4/5 water. Spot leaks easily by looking for bubbles in the soapy water.
3. After the test, deflate the springs to the minimum pressure required to restore the system to normal ride height.
4. Check the air pressure again after 24 hours. A 2 - 4 PSI loss after initial installation is normal. Retest for leaks if the loss is more than 5 lbs.

Fixing Leaks

1. If there is a problem with a swivel fitting:
 - a. Check the air line connection by deflating the spring and removing the line by pulling the collar against the fitting and pulling firmly on the air line. Trim 1" off the end of the air line. Be sure the cut is clean and square (see fig. 7). Reinsert the air line into the push-to-connect fitting.

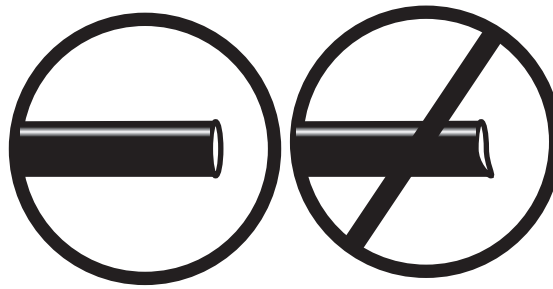

fig. 7

- b. Check the threaded connection by tightening the swivel fitting another $\frac{1}{2}$ turn. If it still leaks, deflate the air spring, remove the fitting, and re-coat the threads with thread sealant. Reinstall by hand tightening as much as possible and then use a wrench for an additional two turns.
2. If the preceding steps have not resolved the problem, call Air Lift customer service at (800) 248-0892.

Warranty and Returns Policy

Air Lift Company warrants its performance products for one year to the original purchaser against manufacturing defects one year from the date of purchase when used on cars and trucks as specified under normal operating conditions. The warranty does not apply to products that have been improperly applied, improperly installed, or which have not been maintained in accordance with installation instructions furnished with all products. The consumer will be responsible for removing (labor charges) the defective product from the vehicle and returning it, transportation costs prepaid, to the dealer from which it was purchased or to Air Lift Company for verification.

Air Lift will repair or replace, at its option, defective products or components. A minimum \$10.00 shipping and handling charge will apply to all warranty claims. Before returning any defective product, you must call Air Lift at (800) 248-0892 in the U.S. and Canada (elsewhere, (517) 322-2144) for a Returned Materials Authorization (RMA) number. Returns to Air Lift can be sent to: Air Lift Company • 2727 Snow Road • Lansing, MI • 48917.

Product failures resulting from abnormal use or misuse are excluded from this warranty. The loss of use of the product, loss of time, inconvenience, commercial loss or consequential damages is not covered. The consumer is responsible for installation/reinstallation (labor charges) of the product. Air Lift Company reserves the right to change the design of any product without assuming any obligation to modify any product previously manufactured.

This warranty gives you specific legal rights and you may also have other rights that may vary from state-to-state. Some states do not allow limitations on how long an implied warranty lasts or allow the exclusion or limitation of incidental or consequential damages. The above limitation or exclusion may not apply to you. There are no warranties, expressed or implied including any implied warranties of merchantability and fitness, which extend beyond this warranty period. There are no warranties that extend beyond the description on the face hereof. Seller disclaims the implied warranty of merchantability. (Dated proof of purchase required.)

Replacement Information

If you need replacement parts, contact the local dealer or call Air Lift customer service at (800) 248-0892. Most parts are immediately available and can be shipped the same day.

Contact Air Lift Company customer service at (800) 248-0892 first if:

- Parts are missing from the kit.
- Need technical assistance on installation or operation.
- Broken or defective parts in the kit.
- Wrong parts in the kit.
- Have a warranty claim or question.

Contact the retailer where the kit was purchased:

- If it is necessary to return or exchange the kit for any reason.
- If there is a problem with shipping if shipped from the retailer.
- If there is a problem with the price.

Contact Information

If you have any questions, comments or need technical assistance contact our customer service department by calling (800) 248-0892, Monday through Friday, 8 a.m. to 8 p.m. Eastern Time. For calls from outside the USA or Canada, our local number is (517) 322-2144. You may also contact customer service anytime by e-mail at techsupport@airliftperformance.com.

For inquiries by mail, our address is PO Box 80167, Lansing, MI 48908-0167. Our shipping address for returns is 2727 Snow Road, Lansing, MI 48917.

You may also contact our sales team anytime by e-mail at sales@airliftperformance.com or on the web at www.airliftperformance.com.

Template

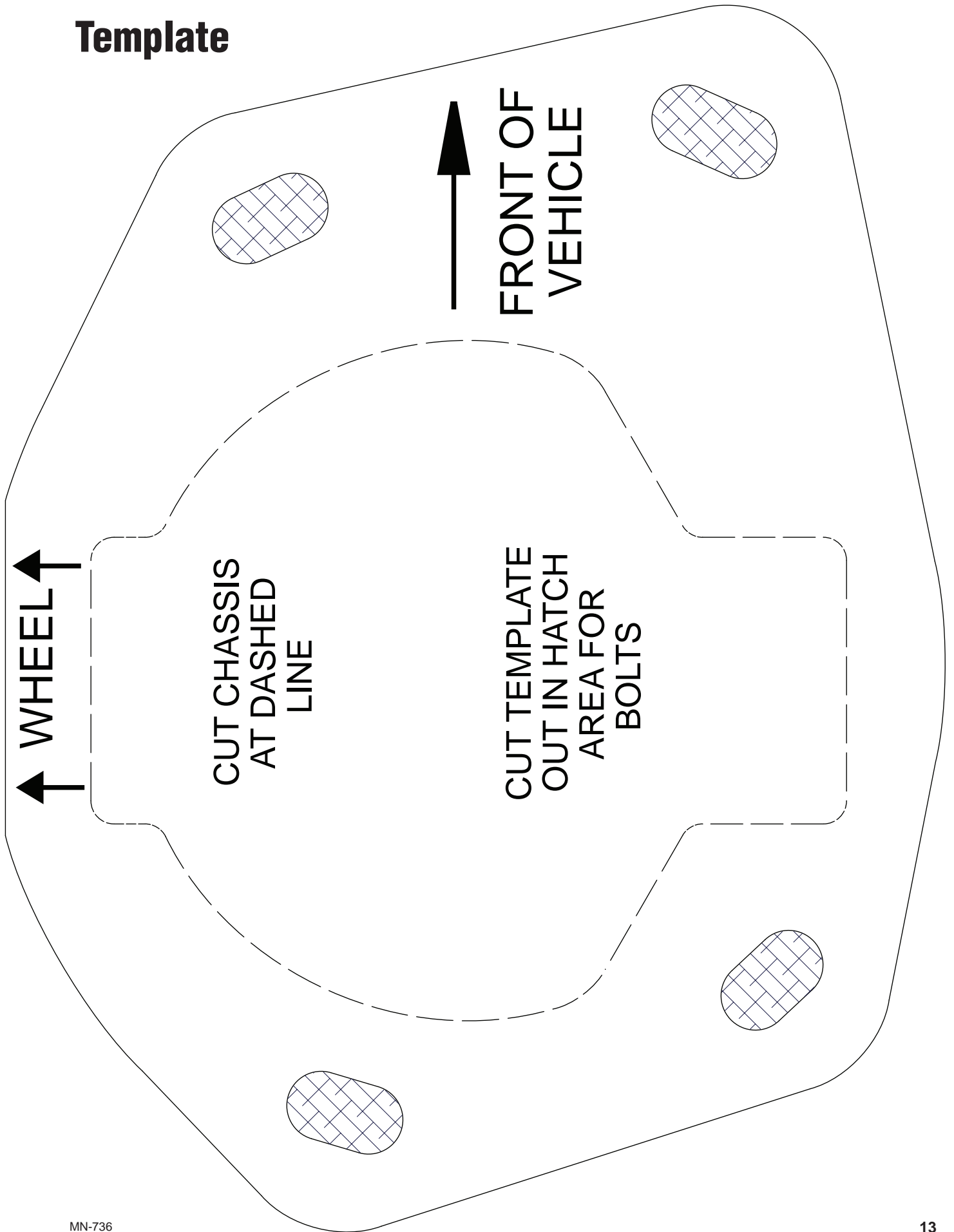

Need Help?

Contact our customer service department by calling (800) 248-0892, Monday through Friday, 8 a.m. to 8 p.m. Eastern Time. For calls from outside the USA or Canada, our local number is (517) 322-2144.



Thank you for purchasing Air Lift Performance products!

Air Lift Company • 2727 Snow Road • Lansing, MI 48917 or PO Box 80167 • Lansing, MI 48908-0167
Toll Free (800) 248-0892 • Local (517) 322-2144 • Fax (517) 322-0240 • www.airliftperformance.com

Printed in
the USA



AutoPilot V2™

PATENT PENDING



- *Calibrate to your vehicle* page 5
- *Automatic preset maintenance*.... page 5
- *Rise on start*..... page 6
- *8 programmable presets* page 7
- *Micro adjust to ± 1 PSI*..... page 10
- *Manual mode with Easy Control™ Tap* page 10



View AutoPilotV2™ videos at:
www.airliftperformance.com/video/

INSTALLATION GUIDE

For maximum effectiveness and safety, please read these instructions completely before proceeding with installation.

Failure to read these instructions can result in an incorrect installation.



TABLE OF CONTENTS

Installing the AutoPilot V2 Kit	3
Setup and Calibration	5
Troubleshooting Guide	6
Program Presets	7
Use the System	10
Electrical Schematic	11
Warranty and Returns Policy	12
Replacement Information	12
Contact Information	12
NPT Assembly Instructions	13
Manifold Template	14
AutoPilot V2 Remote Control Unit	14
16380 Compressor Template	15



Installing the AutoPilot V2 Kit

INSTALL COMPONENTS (SEE FIGURE 17, PAGES 8-9)

- 1. Layout:** Plan component location first. Prior to mounting components, check to make sure the electrical harness connections will reach the manifold and compressor, the compressor leader hose will reach the tank, and the plumbing will route cleanly through the vehicle.

NOTE: Be sure to install all components as far as possible from any heat sources. Plan and prepare harness and plumbing routing thru the vehicle: eliminate all sharp edges that could chafe, use grommets when passing through compartment walls.

NOTE: If harness must be lengthened, use properly sized butt connectors and wire. If extending power/ground wires, use 8AWG wire minimum or contact Air Lift.

NOTE: Air Compressors ingest moisture and will deposit it inside the tank. The AutoPilot V2 system does not include moisture separators or filters, and does require periodic tank moisture drain. If using an Engine Driven compressor, proper oil and water filtration must be added as these compressors will quickly contaminate the air suspension system.

2. Prepare and install:

Compressor

- Prepare compressor intake: if inside vehicle, attach filter to port on end of compressor (Fig. 17). If compressor located outside vehicle, snorkel inlet filter to dry location inside vehicle.
- Center punch and drill four holes using the template on page 15.
- Attach using hardware supplied with compressor.

Manifold

- Locate manifold above compressors and tank if possible to avoid compressor ingested water from gathering in manifold.
- Position manifold in desired location: make sure manifold mount surface is flat.
- Fasten using the two provided self-tapping screws. ***If mounting surface not flat, add washers to space the manifold up over surface irregularities.***

Viair	Max. Tank Pressure
380C	175
400C	150
444C	175
450C	150
480C	175

Tank pre assembly (see fig. 17)

NOTE: compressors ingest moisture and will deposit water in the tank. Tanks must be regularly purged – be sure to provide easy access to drain/fill valve (preferably outside the vehicle).

- Apply thread sealant as necessary.
- Determine tank location and orientation prior to installing fittings.
- In the lower most tank threaded port, install drain/fill PTC fitting.
- Choose a tank threaded port for the compressor fitting.
- Choose highest tank threaded port for manifold airline routing.
- Plug the remaining tank ports with hex plugs.

Tank install (see fig. 17)

- Use tank feet as template, drill holes for hardware assembly.
- Attach tank using supplied hardware.
- Cut appropriate length of hose from the manifold port 5, to the PTC fitting on tank.
- Route drain/fill air line with schrader valve (preferably outside vehicle).

NOTE: Use a standard hose cutter or razorblade. Cut all hose ends square and as smooth as possible.

INSTALL HARNESS

1. Disconnect battery ground while installing system.

2. Compressor / manifold connections (see fig. 17)

- Attach the manifold connector, it will “click” into place once fully seated.
 - Push the tab on the connector to release and remove it.
- Mount the compressor relay in a preferred location using a self-tapping screw.

NOTE: Use appropriate terminal crimp tool to ensure a good connection.

- Cut off the spade and eyelet from the compressor power and ground wires.
- Strip ¼” of wire casing from the compressor wires.
- Strip ¼” of wire casing from the black and pink harness wires.
- Using butt connector attach the RED compressor wire to the PINK harness wire.
- Using butt connector attach the BLACK compressor wire to the BLACK harness wire.
- Carefully apply heat (preferably with a heat gun) to seal these connections.
 - The plastic casing on the butt splice will shrink and seal when heat is applied.

3. Battery / ignition connections (see fig. 17)

- Identify the power/ground + ignition leg of the harness.
 - One 10AWG black wire, One 10AWG red wire, One 18AWG pink wire.
- Route power leg of the harness free from any heat source to the battery.
- Using Butt connector attach the red harness wire to a fuse holder.
- Attach a 3/8” eyelet to the other end of the fuse holder and attach to battery +.
- Attach a 3/8” eyelet to the black wire and attach to battery ground.
- Route the 18AWG pink wire to a key switched ignition source – not accessory.
- Using Butt connector attach the pink ignition wire to a fuse holder.
- Select an auxiliary ignition source and attach the fused ignition wire.
- Use fuse adaptors as necessary.

4. Display

- Route display cable as desired to the preferred operating location.
- Attach the display cable to the main harness cable (small white 3 cavity connector).

5. Reconnect battery

INSTALL AIR LINES

NOTE: Use a standard hose cutter or razorblade. Cut all hose ends square and as smooth as possible.

Route and attach air lines to air springs

- Route air lines free from abrasive edges and heat sources.
- Attach manifold port 1 to the front, drivers side spring “FL” (Front Left).
- Attach manifold port 2 to the front, passengers side spring “FR” (Front Right).
- Attach manifold port 3 to the rear, drivers side spring “RL” (Rear Left).
- Attach manifold port 4 to the rear, passengers side spring “RR” (Rear Right).
- Attach manifold port 5 to the PTC fitting previously installed on the tank.
- Manifold port 6 is the exhaust port.
 - Port 6 can be left open, or routed to a preferred exhaust location.

NOTE: Air lines should be pushed in firmly, with a slight back and forth rotational twist – check connection by pulling on each line to verify robust connection.

NOTE: Release the air line from the fitting by releasing air, pushing on the line, depressing the ring towards the fitting, and then pulling the hose out of the fitting.

Setup and Calibration

AutoPilot V2 is an advanced pressure-based air suspension control system, using state-of-the-art software algorithms to calibrate or map the control system to your vehicle. Once the system is calibrated, the algorithm predicts required “valve open time” to move the air suspension to achieve preset target pressures. AutoPilot V2 has 8 programmable presets, allowing the user to input 8 different combinations of the 4 corner air spring pressures.

After installing AutoPilot V2 in your vehicle, please follow the steps below to properly setup your new system! If changes are made after installing and calibrating the system such as changes to air springs, lines, tank, compressor, or other vehicle modifications the system must be recalibrated.

SYSTEM CALIBRATION AND SETTINGS

1. Key-on power up, compressor should come on to fill the tank.
2. Press buttons 1 and 5 at the same time (1+5) and hold for 5-10 seconds until settings and diagnostics mode main page appears (fig. 2).
3. Press button 1: TANK ADJUST. Set tank pressure preference by pressing MIN and MAX up/down buttons (fig. 3). Press buttons 1+5 to exit to settings and diagnostics mode.

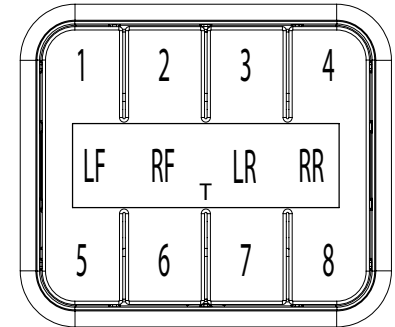

fig. 1

Button Definition

Calibrate to your vehicle

NOTE: System will automatically deflate to 0 PSI and inflate to 100 PSI.

4. Press button 2 to enter CALIBRATE (fig. 4). Press SYSTEM CAL Button 1, follow instructions to calibrate AutoPilot V2 system to your vehicle. Once calibration is complete, Press buttons 1+5 to exit to settings and diagnostics mode.
5. Press button 3 to enter BACKLIGHT (fig. 5). Set display backlight to your preference by pressing the + and – on R (Red), G (Green), B (Blue). Press buttons 1+5 to exit to settings and diagnostics mode.

fig. 2

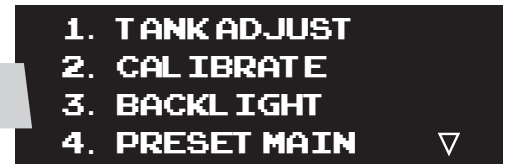

fig. 3



fig. 4

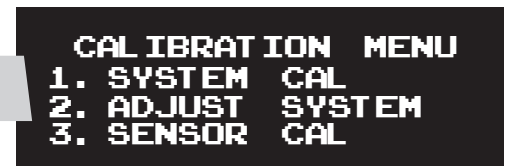

fig. 5

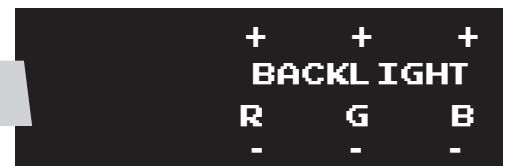

fig. 6



Automatic preset maintenance

6. Press button 4 to enter PRESET MAINTAIN (fig. 6). Press Button 8 to turn ON or OFF. When ON, this function actively monitors air spring pressure and will fill to maintain active preset pressure. If any corner requires 3 or more inflates, System will alert LEAK, displaying an “L” next to the suspect air spring pressure.

NOTE: This function will not exhaust pressure. If air spring pressure is higher than preset target, only the operator pressing the preset button again will activate the system to exhaust air spring pressure (for safety). Press buttons 1+5 to exit.

NOTE: PRESET MAINTAIN should be off for performance/ track driving or if operating in extremely hilly areas.

7. Press button 8 to toggle to settings page 2 (fig. 7).
8. Press button 5 to run a compressor test (fig. 8). This function will exhaust the tank to your specified MIN tank pressure, then turn ON the compressor and measure its inflate time to achieve MAX pressure. AutoPilot V2 will record this fill time, allowing the operator to compare future fill times to determine compressor performance. Press buttons 1+5 to exit.
9. Press button 6 to view the number of hours the compressor has been running.

Rise on start

10. Press button 7 to enter RISE ON START (fig. 9). This function will automatically activate valves to achieve preset 1 target pressures when the vehicle is keyed-on. This function allows the operator to drive away seconds after vehicle is started. Press buttons 1+5 to exit.
11. Press button 8 to toggle between PSI and BAR pressure units and check software version. Press buttons 1+5 to exit.
NOTE: BAR is actually DeciBar values.
12. Press buttons 1+5 to exit settings and diagnostics – you are now ready to create presets!

PRESSURE SENSOR CALIBRATION

If the AutoPilot V2 system experiences a pressure reading that appears to be incorrect or if the Display instructs you that calibration is required (fig. 10), then please follow the procedure below.

1. Enter Settings Menu.
2. Select Calibration Menu (fig. 2).
3. Select Sensor Cal (fig. 4).
4. Follow the text on the display to calibrate the pressure sensors (figs. 10 & 11).
 - a. You will be required to disconnect all the air lines from the manifold for the calibration process to complete.
 - b. Once complete connect the air lines.

fig. 7

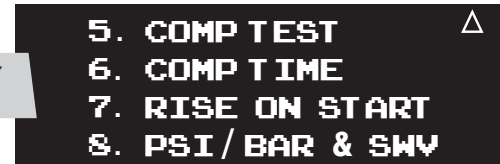

fig. 8

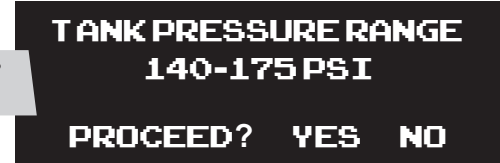

fig. 9



fig. 10

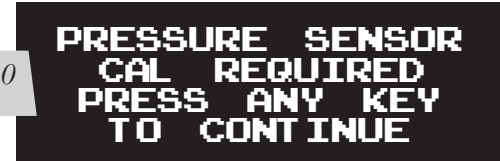

fig. 11

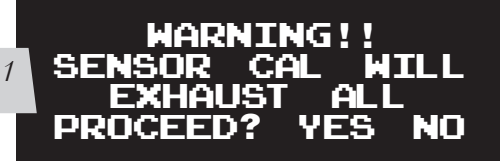

fig. 12



Program Presets

NOTE: Preset 1 should always be entered as the desired ride pressure for the RISE ON START function.

1. Determine ride pressures: press buttons 1+5 to toggle display to MANUAL MODE. Manually activate each corner (see MANUAL Mode section page 10) to achieve desired “normal driving” ride pressure. (fig. 13)

8 programmable presets

2. Program preset 1: press buttons 1+5 to toggle display to PRESET MODE. Press and hold button 1 to set 1: release button and actual air spring pressures will appear (fig. 11). Fine-tune the pressures by pressing up/down buttons. Press + hold to scroll. Press buttons 1+5 to exit.
 - “Low”: set pressures to the lowest possible pressures for extreme low driving stance
 - “Front up”: for speed bump or driveway clearance
 - “Rear up”: for added load of passengers, equipment
 - “Play”: for those that want to enjoy their air suspension freedom, AutoPilot V2 has a special function that recognizes side-side presets. When left side pressures are equal, and right side pressures are equal but >25psi different than left, the algorithm will activate side to side instead of front to back. It will also equalize all air spring pressures when exiting the “play” preset, conserving air by using the high pressure side to inflate the low pressure side. Pairing two “play” presets together allows side-side activation that consumes far less air than manual mode activation would consume (Figs. 15 & 16).
3. You are now free to program the additional 7 presets to desired pressures. Typical presets can be:
 - “Low”: set pressures to the lowest possible pressures for extreme low driving stance
 - “Front up”: for speed bump or driveway clearance
 - “Rear up”: for added load of passengers, equipment
 - “Play”: for those that want to enjoy their air suspension freedom, AutoPilot V2 has a special function that recognizes side-side presets. When left side pressures are equal, and right side pressures are equal but >25psi different than left, the algorithm will activate side to side instead of front to back. It will also equalize all air spring pressures when exiting the “play” preset, conserving air by using the high pressure side to inflate the low pressure side. Pairing two “play” presets together allows side-side activation that consumes far less air than manual mode activation would consume (Figs. 15 & 16).

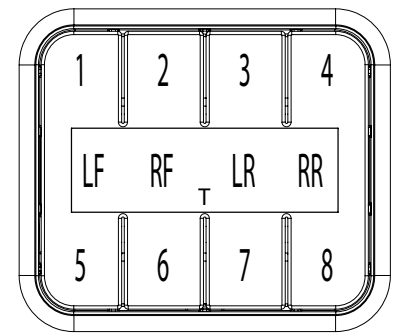

fig. 1

Button Definition



fig. 13



fig. 14



fig. 15



fig. 16

Troubleshooting Guide

For further technical assistance please contact our customer service department by calling (800) 248-0892, Monday through Friday, 8 a.m. to 8 p.m. Eastern Time. For calls from outside the USA or Canada, our local number is (517) 322-2144.

PROBLEM	CAUSE	SOLUTION
<i>Compressor doesn't run.</i>	There is a blown fuse or relay, bad ground, or poor electrical connections.	Replace the fuse, check the ground wire, or check the compressor connector.
<i>Compressor runs all the time.</i>	The compressor relay is defective or there is a leak.	Replace the relay or locate the leak and repair.
<i>Air spring or tank leak.</i>	Fitting seal or air line compromised.	Check to make sure air lines are seated in connectors. Inspect fittings with soapy water. Trim hose or re-seal fitting.
<i>Nothing happens when the vehicle is key-on ignition active.</i>	There is a blown fuse or a poor connection.	Replace the fuses and check the electrical connections.
<i>The display does not light up.</i>	There is a blown fuse or a poor connection.	Replace the fuses and check the electrical connections.
<i>Compressor runs all the time but no fill tank.</i>	Compressor inline check valve fitting has been overtightened.	Loosen fitting and check again. Replace if needed.
<i>System takes more than 4 iterations to achieve target pressure.</i>	Calibration may need to be adjusted or system may need to be recalibrated.	Adjust “ADJ” value or Recalibrate system to reduce # of iterations.
<i>Spring pressures are not zero when fully deflated.</i>	Pressure sensor calibration is off.	Recalibrate using Pressure Sensor Calibration Routine.

Connect direct to battery

fig. 17

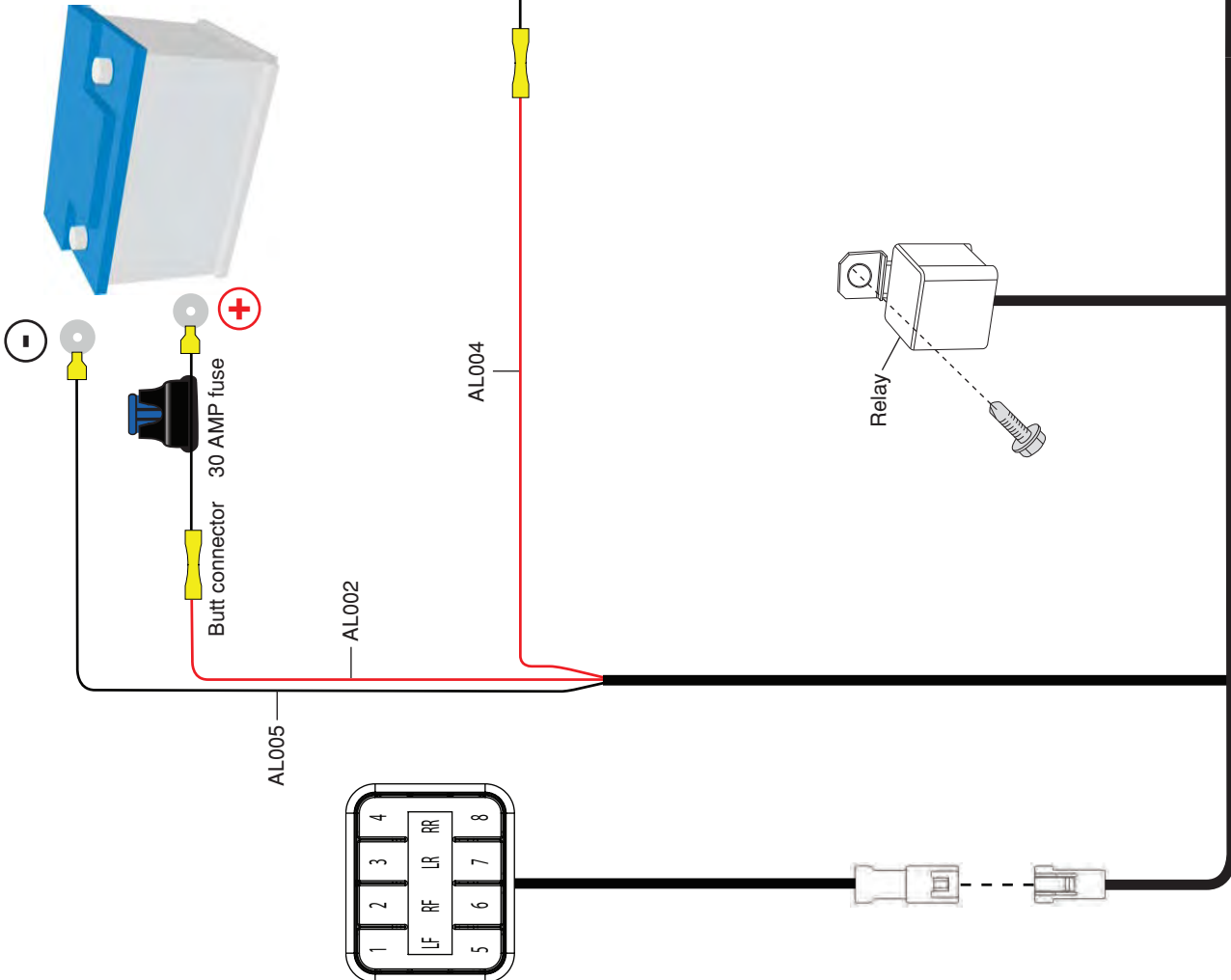

Ignition Source (on while cranking)

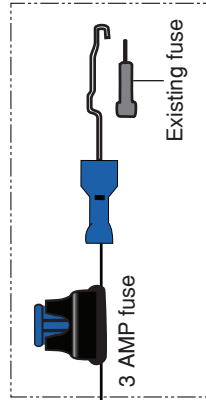

Relay schematic reference

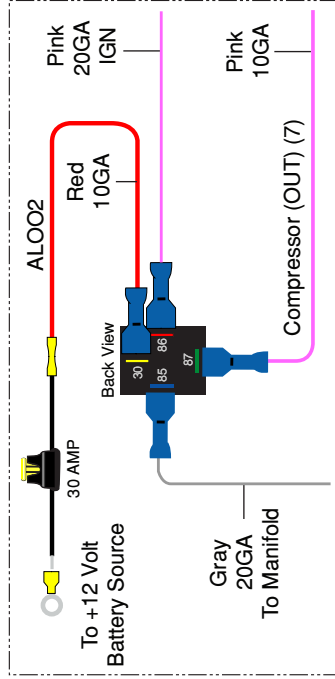

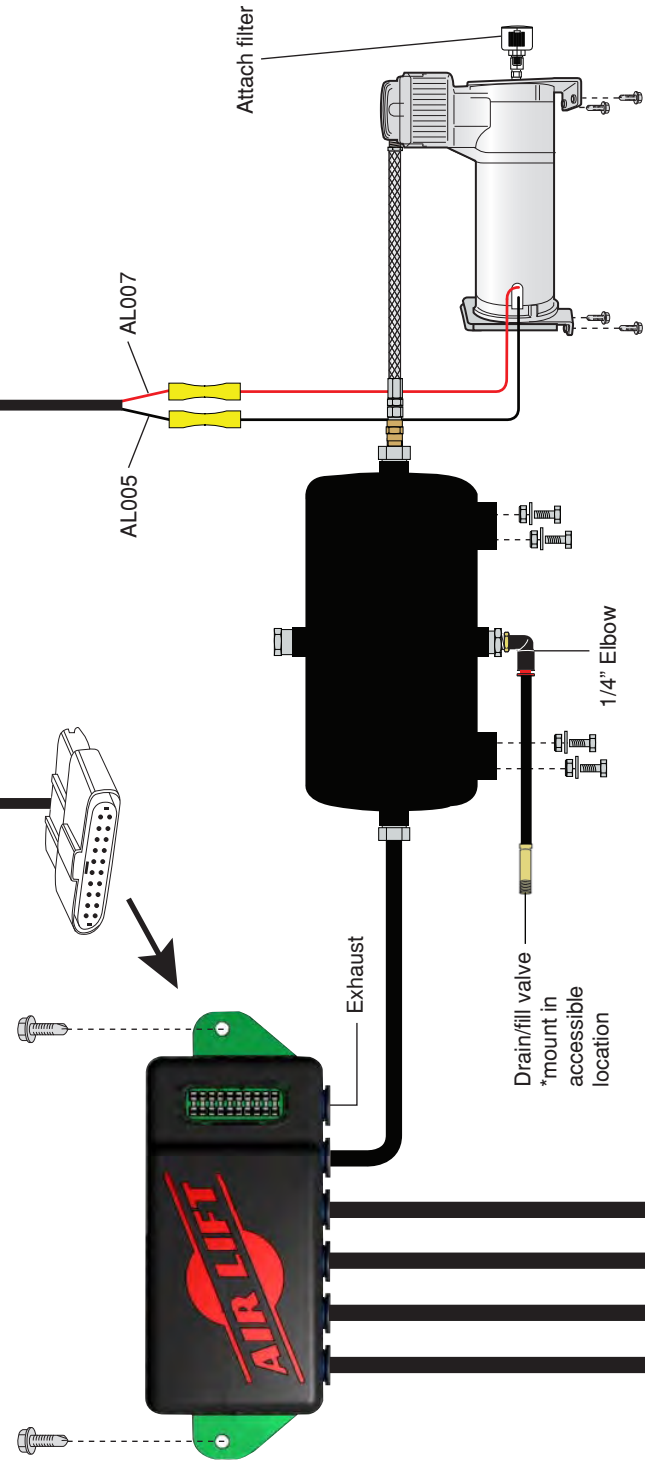

To add a second compressor

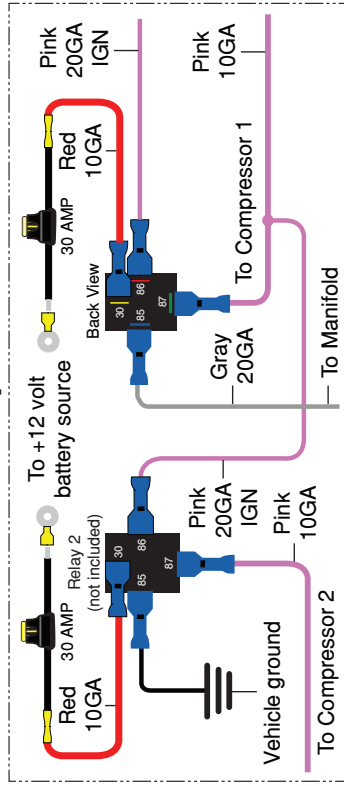

NOTE: Air Lift recommends using a hose cutting tool to ensure a proper cut.

If a hose connection has been disconnected the hose must be trimmed 1/2" back to provide for a leak free seal.

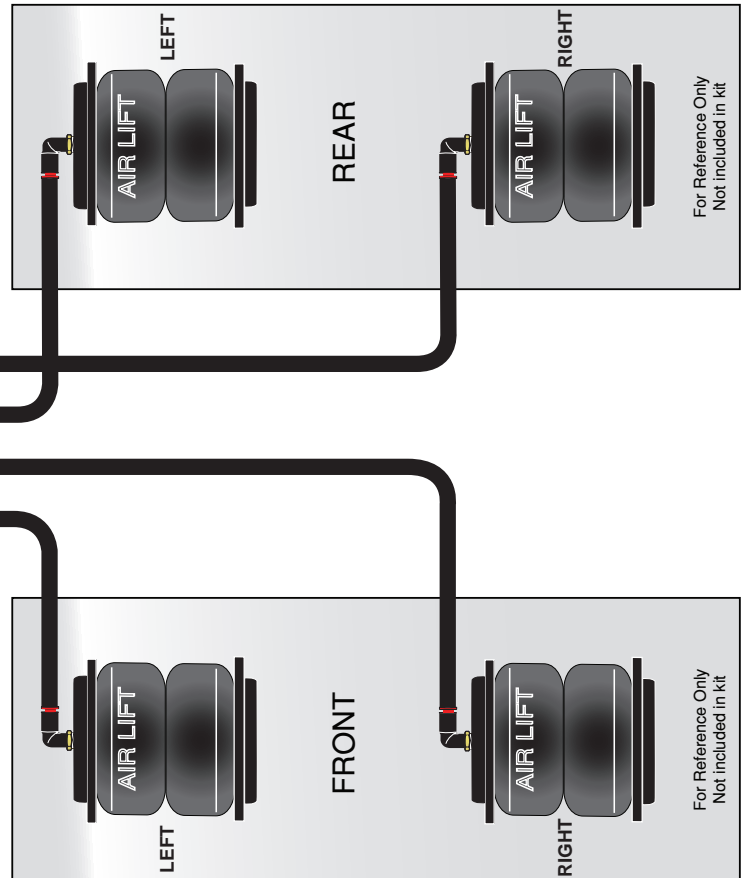
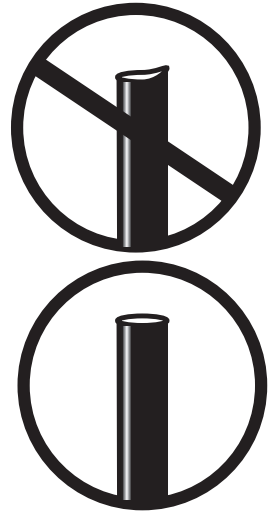

Use the System

Now that your system is set up, it's time to use it. If changes are made after installing and calibrating the system such as changes to air springs, lines, tank, or compressor the system must be recalibrated.

There are two modes: PRESET, and MANUAL. Pressing buttons 1 and 5 together will toggle between modes. After 10 seconds of non-use, the display enters standby where the LCD dims. Any button hit will "wake-up" the display and allow users to activate the system. See mode operation below for more details.

PRESET mode

- First button press will display the programmed preset. Users can quickly view each preset prior to activating to make sure they are selecting the desired preset.
- 2nd button press of the same preset will activate it. The system will iterate up to 6 times to achieve the preset target pressures by +/- 3 psi. Display shows "PLEASE WAIT" as it iterates, then will flash "SUCCESSFUL" when achieved or "UNSUCCESSFUL" if not able to achieve the target pressure window. NOTE: if your system is not hitting Presets quickly, change the "ADJ" value. Enter "Settings and Diagnostics" mode (press Button 1+5 for more than 5 seconds), press #2 CALIBRATE, then ADJUST SYSTEM to toggle the value between 0 and 10; higher values increase system fill rates to overshoot target pressures.

🔑 **Micro adjust to ±1 PSI:** If more accuracy is desired, double press the same preset and the system will refine pressures closer to target .

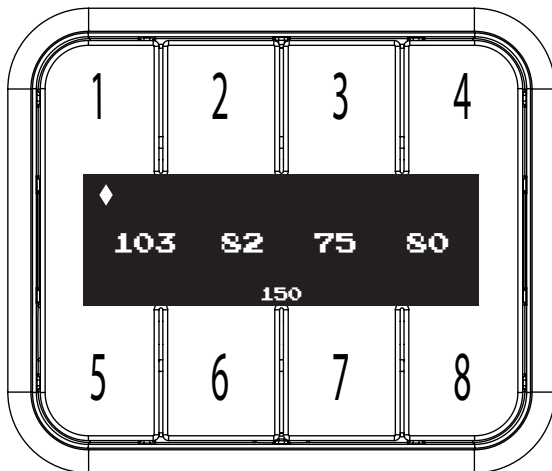

fig. 18 **Preset Mode**

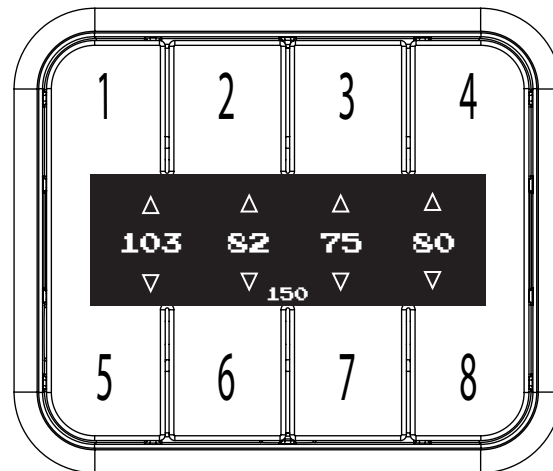

fig. 19 **Manual Mode**

MANUAL mode

MANUAL mode allows the user to fill or exhaust each spring. The display will show arrows above and below the pressures to indicate manual control mode. The arrow will be solid when the spring is filling / exhausting, and just an outline when not active.

🔑 **Manual mode with Easy Control Tap™**

The system detects button press time. For a very short (<0.1sec) duration press, the system will open the valves for a defined "burst", changing pressure minimally so users can fine-tune their pressures. For a longer than 0.1 sec duration press, the valves open as long as you hold it down. If a button is held active the fill / exhaust will timeout after 10 seconds.

- Fill springs: buttons 1 - 4
- Exhaust springs: buttons 5 - 8

Electrical Schematic

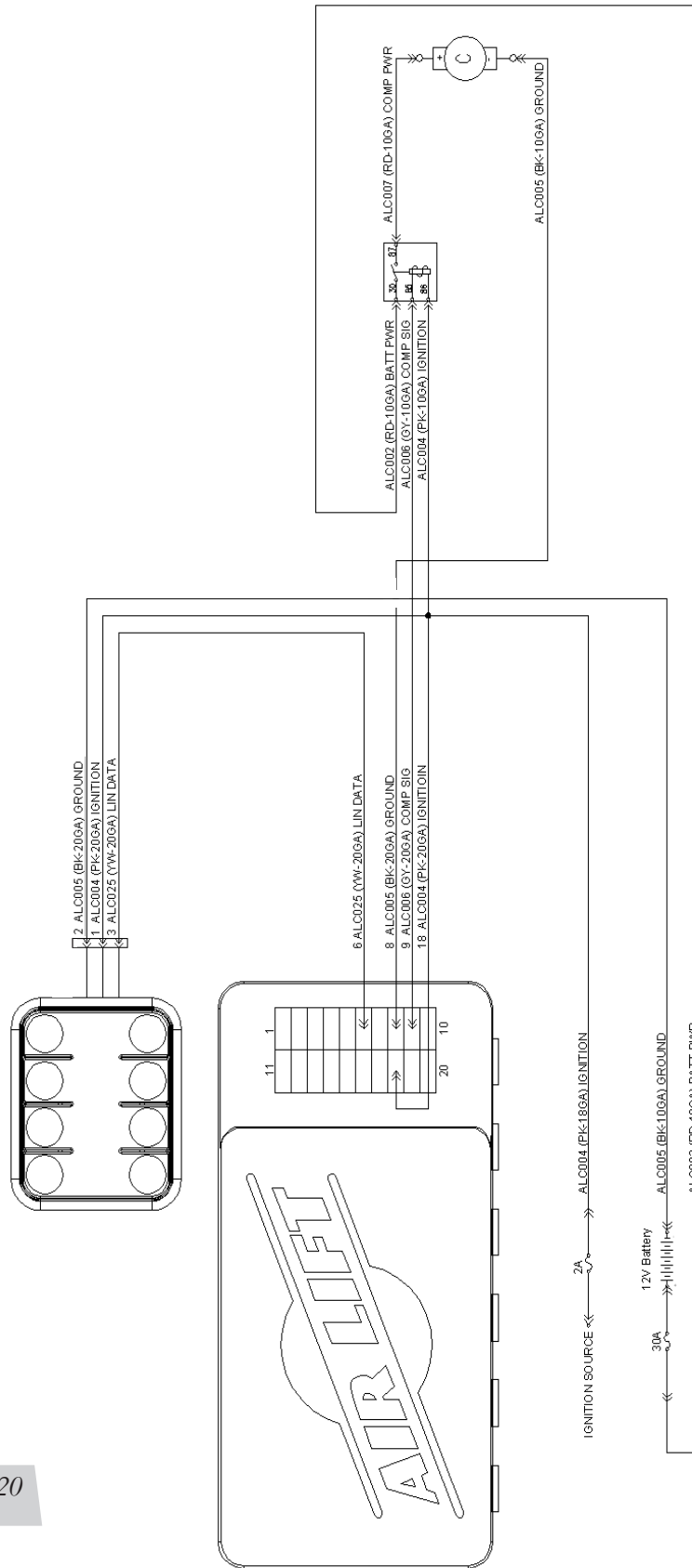

fig. 20

Warranty and Returns Policy

Air Lift Company warrants its performance products for one year to the original purchaser against manufacturing defects one year from the date of purchase when used on cars and trucks as specified under normal operating conditions. The warranty does not apply to products that have been improperly applied, improperly installed, or which have not been maintained in accordance with installation instructions furnished with all products. The consumer will be responsible for removing (labor charges) the defective product from the vehicle and returning it, transportation costs prepaid, to the dealer from which it was purchased or to Air Lift Company for verification.

Air Lift will repair or replace, at its option, defective products or components. A minimum \$10.00 shipping and handling charge will apply to all warranty claims. Before returning any defective product, you must call Air Lift at (800) 248-0892 in the U.S. and Canada (elsewhere, (517) 322-2144) for a Returned Materials Authorization (RMA) number. Returns to Air Lift can be sent to: Air Lift Company • 2727 Snow Road • Lansing, MI • 48917.

Product failures resulting from abnormal use or misuse are excluded from this warranty. The loss of use of the product, loss of time, inconvenience, commercial loss or consequential damages are not covered. The consumer is responsible for installation/reinstallation (labor charges) of the product. Air Lift Company reserves the right to change the design of any product without assuming any obligation to modify any product previously manufactured.

This warranty gives you specific legal rights and you may also have other rights that may vary from state-to-state. Some states do not allow limitations on how long an implied warranty lasts or allow the exclusion or limitation of incidental or consequential damages. The above limitation or exclusion may not apply to you. There are no warranties, expressed or implied including any implied warranties of merchantability and fitness, which extend beyond this warranty period. There are no warranties that extend beyond the description on the face hereof. Seller disclaims the implied warranty of merchantability. Dated proof of purchase required.

Replacement Information

If you need replacement parts, contact the local dealer or call Air Lift customer service at (800) 248-0892. Most parts are immediately available and can be shipped the same day.

Contact Air Lift Company customer service at (800) 248-0892 first if:

- Parts are missing from the kit.
- Broken or defective parts in the kit.
- Technical assistance on installation or operation is needed.
- Wrong parts in the kit.
- Have a warranty claim or question.

Contact the retailer where the kit was purchased:

- If it is necessary to return or exchange the kit for any reason.
- If there is a problem with shipping, if shipped from the retailer.
- If there is a problem with the price.

Contact Information

If you have any questions, comments or need technical assistance contact our customer service department by calling (800) 248-0892, Monday through Friday, 8 a.m. to 8 p.m. Eastern Time. For calls from outside the USA or Canada, our local number is (517) 322-2144. You may also contact customer service anytime by e-mail at techsupport@airliftperformance.com.

For inquiries by mail, our address is PO Box 80167, Lansing, MI 48908-0167. Our shipping address for returns is 2727 Snow Road, Lansing, MI 48917.

You may also contact our sales team anytime by e-mail at sales@airliftperformance.com or on the web at www.airliftperformance.com.

NPT Assembly Instructions

1. Inspect port and fitting to ensure both are free of contaminants and excessive burrs and nicks.
2. Apply a stripe of liquid pipe sealant around the male threads leaving the first two threads uncovered.
3. Screw finger tight into the port.
4. Wrench tighten the fitting to the correct Turns Past Finger Tight position (see following table).

CAUTION: NEVER BACK OFF AN INSTALLED PIPE FITTING TO ACHIEVE PROPER ALIGNMENT. LOOSENING INSTALLED PIPE FITTINGS WILL CORRUPT THE SEAL AND CONTRIBUTE TO LEAKAGE AND FAILURE.

Torque Specifications			
Fitting Size	Dash Size	Turns Past Finger Tight	Torque ft/lbs
1/8" NPT	-02	1.5 - 3.0	12
1/4" NPT	-04	1.5 - 3.0	25
3/8" NPT	-06	1.5 - 3.0	40
1/2" NPT	-08	1.5 - 3.0	54
3/4" NPT	-12	1.5 - 3.0	78
1" NPT	-16	1 - 2.5	112
1 1/4" NPT	-20	1 - 2.5	154
1 1/2" NPT	-24	1 - 2.5	211
2" NPT	-32	1 - 2.5	300

Table 1

Manifold Template

AutoPilot V2 Remote Control Unit

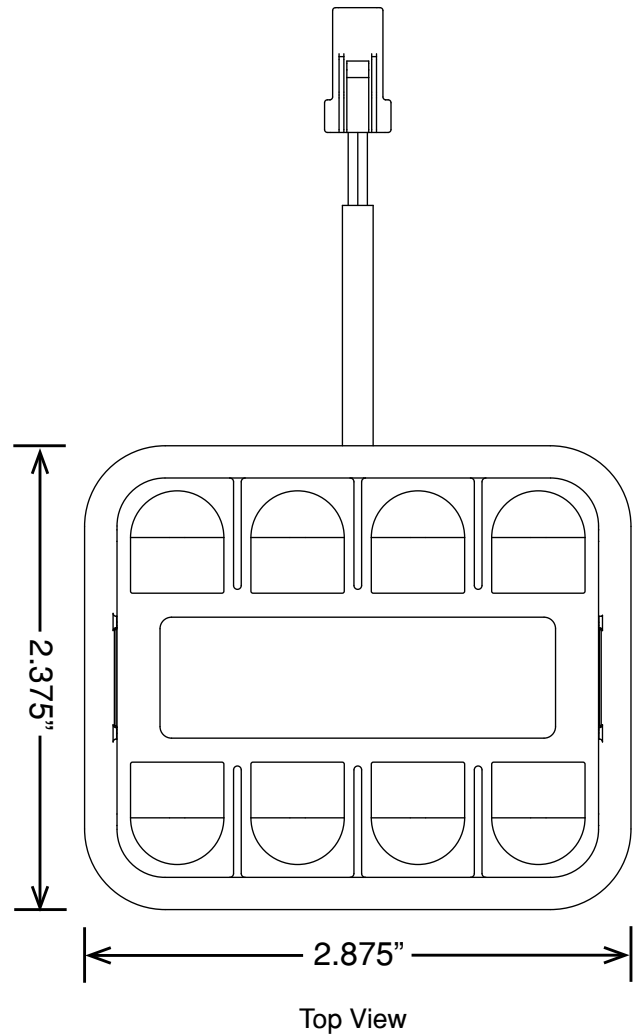
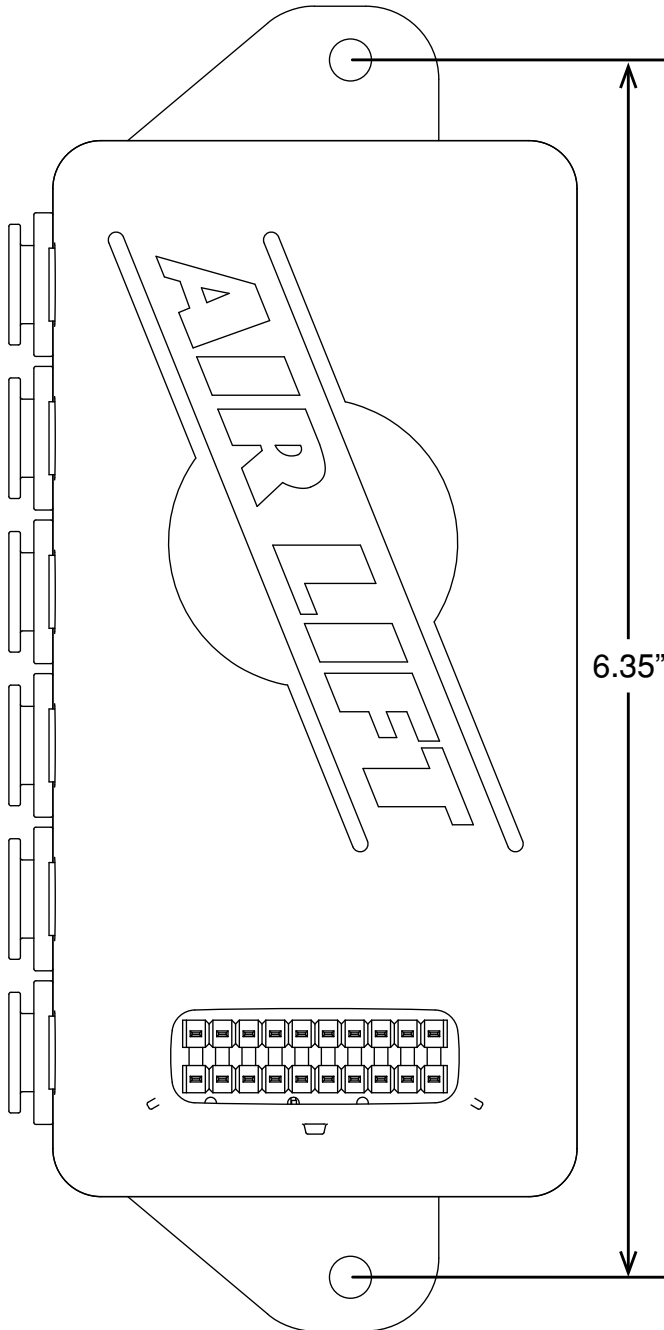

16380 Compressor Template

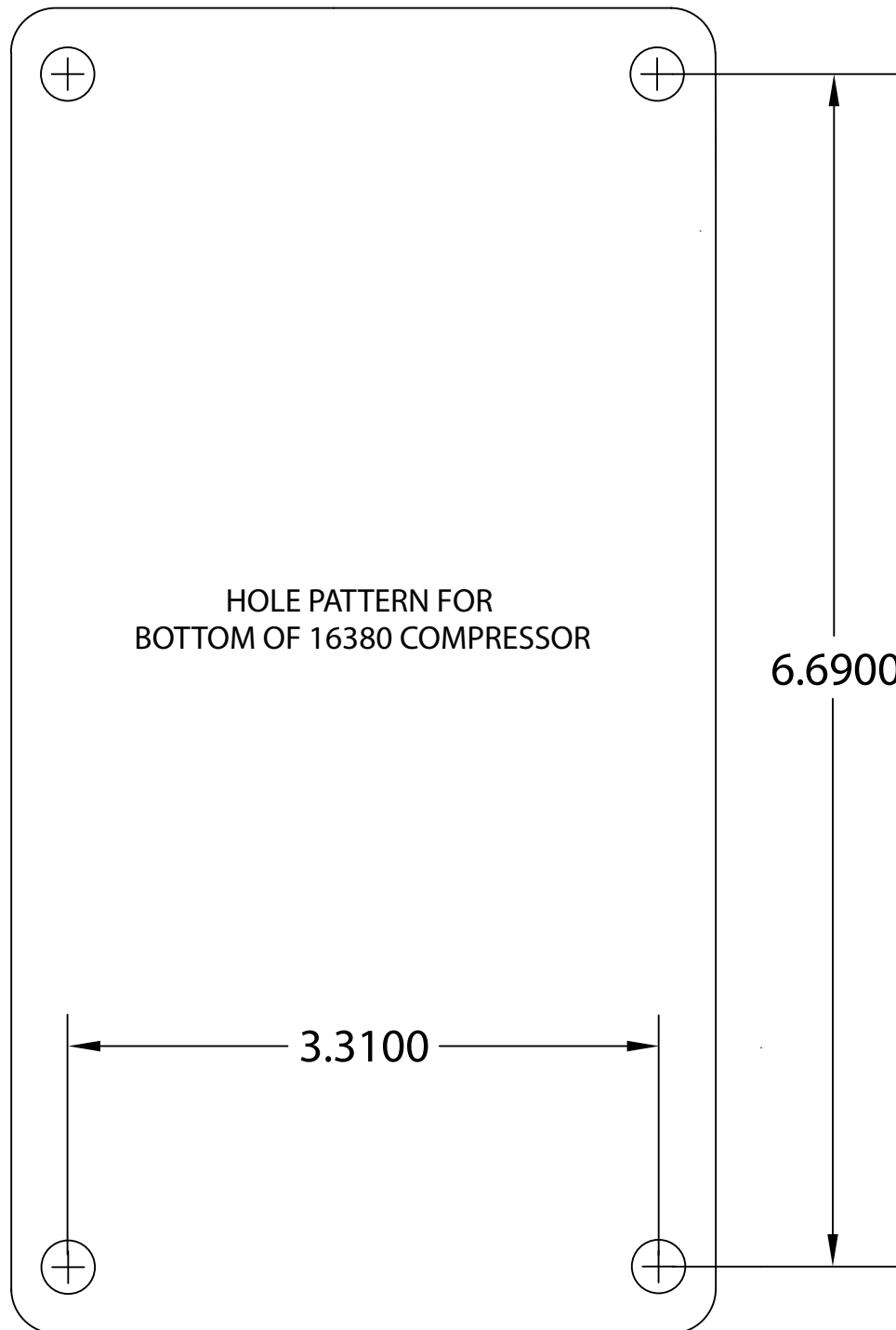

Need Help?

Contact our customer service department by calling (800) 248-0892, Monday through Friday, 8 a.m. to 8 p.m. Eastern Time. For calls from outside the USA or Canada, our local number is (517) 322-2144.



Thank you for purchasing Air Lift Performance products!

Air Lift Company • 2727 Snow Road • Lansing, MI 48917 or PO Box 80167 • Lansing, MI 48908-0167
Toll Free (800) 248-0892 • Local (517) 322-2144 • Fax (517) 322-0240 • www.airliftperformance.com

Printed in
the USA

Kit Details

27671



HARDWARE LIST

Part #	Description	Qty	Part #	Description	Qty
72605	4pt Fast Air Manifold - 1/4".....	1	24542	ATC/ATO Fuse Adaptor.....	1
27042	Gen 3 Display	1	21247	1/2" MNPT X 1/4" FNPT.....	3
26498-002	Electrical Harness - FastAir	1	21190	1/2" MNPT Center Sunk Hex Plug.....	4
20946	DOT 1/4" Air Line.....	2ft	21779	DOT Swivel Elbow 1/4Pipe - 1/4 PTC	1
22630	DOT Elbow 1/4PTC - 1/4PTC.....	6	21993	DOT Swivel Elbow 1/4MNPT-1/4PTC.	1
24672	Fuse, spade 3amp	1	21633	Push Lock Valve	1
24547	Fuse, spade, 30amp	1	20946	DOT 1/4" Air Line	50ft
24500	ATC Fuse holder w/ cap	2	17263	1/4-14 X 1 Heavy Duty Washer	3
24645	16GA Butt Connector.....	1	18444	3/8" Flat Washer	8
24752	12-10GA Butt Connector.....	3	17188	3/8-16 x 1.25 Hex Cap Screw	4
24748	12GA Ring Terminal 3/8"	2	18435	3/8-16 Nyloc Nut	4
24524	Female Spade Terminal.....	1	16380	Compressor (200 psi)	1
24595	12GA Female Spade Terminal	1	10991	Air Tank (5 gallon).....	1
24561	Adaptor, Mini Fuse.....	1	10466	8" Zip Tie.....	10



Missing or damaged parts? Call Air Lift customer service at (800) 248-0892 for a replacement part.