

Please read these instructions completely before proceeding with the installation.

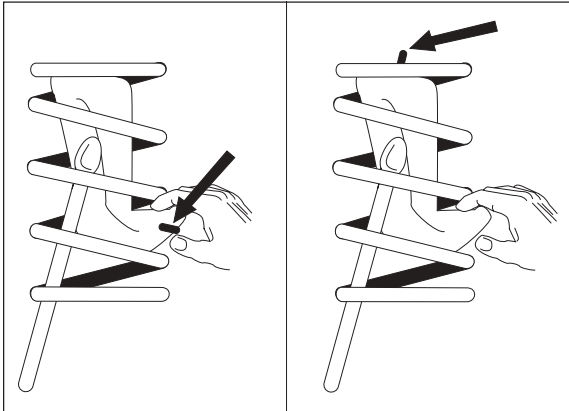

Figure 1A

Figure 1B

**IMPORTANT:** This kit fits several different vehicles. Please consult the following listings for the appropriate section for your particular vehicle.

**Section A:** General Motors A (Century, Celebrity, Cutlass Cierra 6000) and X (Skylark, Citation, Omega, Phoenix) front wheel drive, with solid rear axle cars; Ford, Lincoln, Mercury full size and mid-size cars; Chevy Lumina APV, Olds Silhouette, and Pontiac Transport; Nissan Pathfinder; Isuzu Trooper, Amigo, and Vehicross

**Section B:** Camaro, Firebird, Monza, Skyhawk, Starfire, Astre, Sunbird, and Vega

**Section C:** General Motors E (Toronado, Riviera, El Dorado, Seville) and H (LeSabre, Electra, Park Ave, DeVille, Eighty-Eight, Ninety-Eight, and Bonneville) Cars; Kia Sedona Van; Nissan Morano, Toyota Scion XB.

## Section A Installation

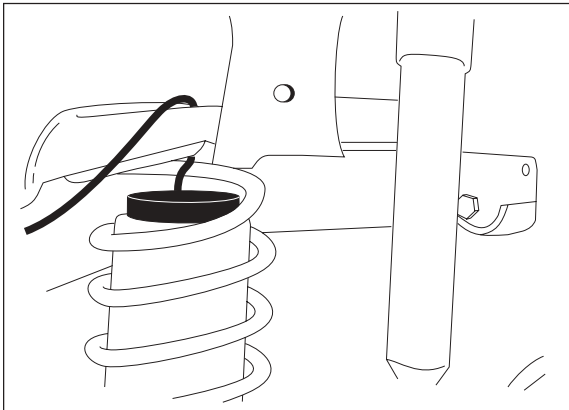

Figure 2

1. Some Ford, Lincoln, and Mercury models come equipped with a rubber sleeve inside of the rear coil springs. This needs to be removed prior to proceeding with the installation. It can either be cut out or pulled out with vise grips.
2. Remove the plastic cap from the barbed stem on the end of the air cylinder and exhaust all the air from the cylinder by rolling it up towards the barbed stem. Replace the cap so that the cylinder holds its flat shape. Form the cylinder into a hot dog bun shape. If necessary, use string, tape, or wire to retain this shape.
3. Lower axle or raise body of vehicle until suspension is fully extended.
4. If necessary, additional clearance between the coil may be obtained by removing the shock absorbers from the lower mountings and lowering the suspension an additional two inches. **CAUTION:** Observe the tension on the brake line. Do not strain.
5. Insert the stem end of the air cylinder into the lowest opening of the coil (valve stem up). Push the cylinder into the coil spring by hand or with a blunt object such as a spoon type tire iron (Figure 1B).
6. When the air cylinder is completely within the coil, remove the cap and allow the cylinder to assume its original shape.
7. Push the cylinder to the bottom of the coil and insert the protector on top of the cylinder (Figure 2),
8. Complete the installation with installing the air lines found on page 2.

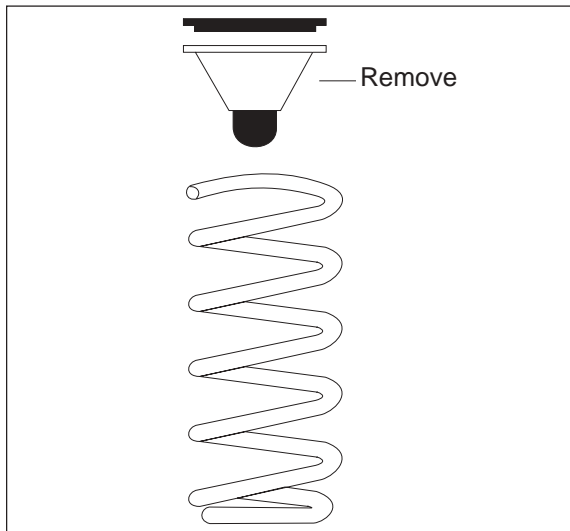

Figure 3

## Section B Installation

1. Jack up rear of vehicle or raise on hoist. Support frame with safety stands.
2. Detach the shock absorber lower ends from the axle. Lower the axle or raise the body to permit the removal of the coil spring.
3. 1975 and up Vega, Monza, Starfire, Skyhawk, and Sunbird only:
  - a. Remove the upper bound bumper/cone assembly with coil spring (Figure 3). The bumper/cone assembly will not be reused, as the air cylinder replaces their function.

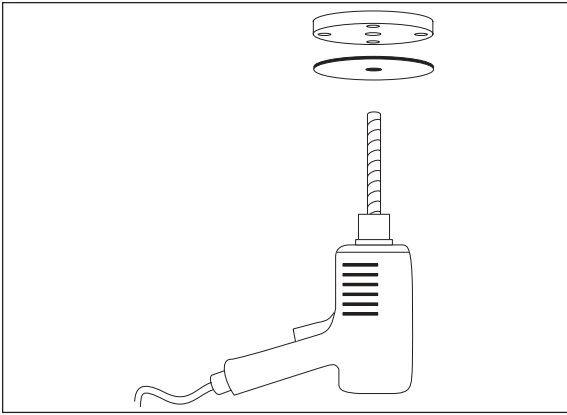

Figure 4

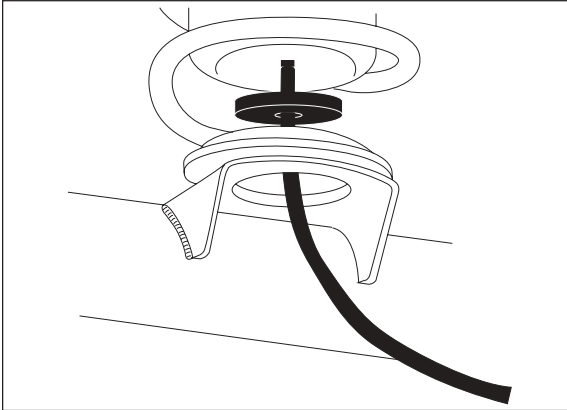
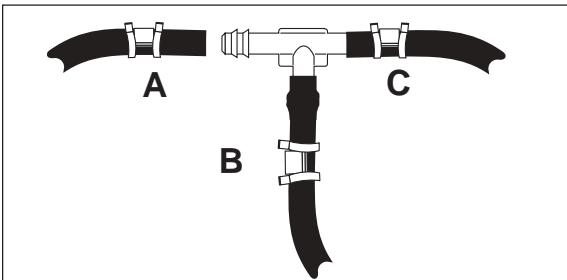

Figure 5



Use this procedure for all air line connections:  
 A. Slide air line clamp onto the air line.  
 B. Push air line over the barbed stem.  
 C. Compress the ears on the air line clamp with pliers and slide it forward to fully covers the barbed section.

Figure 6

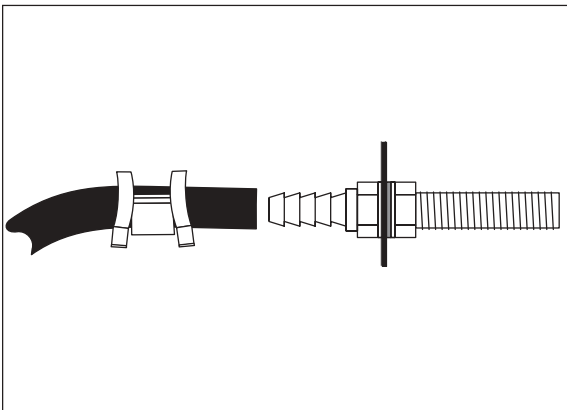

Figure 7

b. Cut out circle "C" on template and place onto the lower spring seat with a dab of grease to hold in position. Center punch and drill a 1/2" hole (Figure 4).

4. Remove the plastic cap from the barbed stem on the end of the air cylinder and exhaust all the air from the cylinder by rolling it up towards the barbed stem. Replace the cap so that the cylinder holds its flat shape. Form the cylinder into a hot dog bun shape. If necessary, use string, tape, or wire to retain this shape.
5. Insert the air cylinder into the coil with the stem down.
6. When the cylinder is completely within the coil, remove the cap and allow the cylinder to assume its original shape.
7. If removed, place the upper spring insulator on top of the coil spring. Index it so that the notch fits on the end of the spring.
8. Replace the coil springs and air cylinder assembly into the vehicle spring seats, insuring that the end of the spring is indexed properly into the notch in the seat.
9. Push cylinder to the top of the coil spring and insert the protector on top of the lower spring seat (Figure 5).
10. Complete the installation with installing the air lines.

## Section C Installation

1. Jack up rear of vehicle or raise on hoist. Support frame with safety stands. Lower axle or raise body of vehicle until suspension is fully extended.
2. Some of the vehicles in this section do not have a hole in the lower spring. Cut out circle "D" on the template and place into the lower spring seat and hold in place with a dab of grease. Center punch and drill a 3/4" hole in the marked location.
3. Remove the plastic cap from the barbed stem on the end of the air cylinder and exhaust all the air from the cylinder by rolling it up towards the barbed stem. Replace the cap so that the cylinder holds its flat shape. Form the cylinder into a hot dog bun shape. If necessary, use string, tape, or wire to retain this shape.
4. Insert the air cylinder into the coil with the stem down. Push the cylinder into the coil spring by hand or carefully with a blunt object such as a spoon type tire iron (Figure 1A).
5. When the air cylinder is completely within the coil, remove the cap and allow it to assume its original shape.
6. Push the cylinder to the top of the coil and insert the protector on the bottom of the cylinder (Figure 5).
7. Complete the installation by installing the air lines.

## Installing the Air Line

*Tee air line installation is recommended unless weight in vehicle varies from one side to the other and unequal pressures are needed to level the load. Dual air lines are used in this case.*

1. Tee Air Line routing:  
*IMPORTANT: To prevent air line from melting, keep it at least 8" from the exhaust system.*
  - a. Locate desired tee location on the frame rail or cross member.

- b. Determine and cut adequate length of air line to reach from tee to left and right side on air cylinders. *CAUTION: Leave sufficient air line slack to prevent any strain on fitting during axle motions.*
  - c. Slide air line clamp onto the air line.
  - d. Push the air line over one side of the tee until all the barbs are covered. Repeat procedure for other leg of tee. With pliers slide the air line clamp forward until it fully covers the barbed section. Repeat for other leg of tee (Figure 7).
  - e. Route along cross member and lower control to air cylinder.
  - f. Insert air line through lower control arm.
  - g. Push the air line onto the stem of the air spring, covering all the barbs (Figure 8). With pliers slide the air line clamp upward until it fully covers the barbed section.
  - h. Push the remaining air line over the last fitting on tee and route along frame to desired inflation valve location (Figure 9). Attach with plastic straps or wire.
  - i. Select a location for inflation valve in the gas cap well, the truck, rear bumper, fender flange or behind the license plate, insuring that the valve will be protected and accessible with an air hose.
  - j. Drill a  $\frac{5}{16}$ " hole for inflation valve and mount as in illustration (Figure 11). Rubber washer is for outside weather seal.
  - k. Slide air line clamp over the air line. Push air line onto fitting covering all barbs, with pliers slide the air line clamp forward until it fully covers the barbed section (Figure 7).
  - l. Raise axle or lower body until air cylinders lightly touch upper spring seat and lower spacers.
  - m. Check tail pipe clearance and insure that it is at least 2-3 inches from air cylinder. If necessary, loosen clamps and rotate or move to obtain additional clearance. If heat shield is provided, install it. Attach shock absorbers if removed earlier in the installation.
- CAUTION: Do not inflate air cylinders before reading the maintenance and operation tips.*

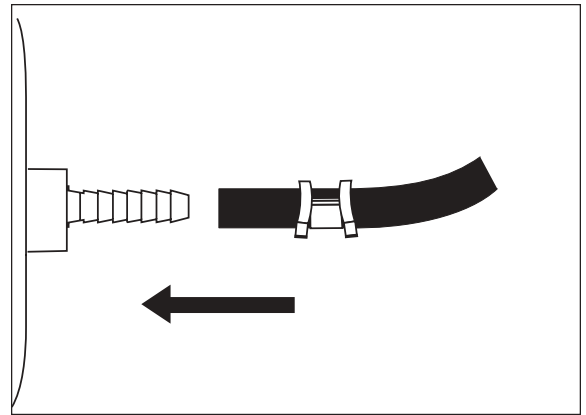

Figure 8

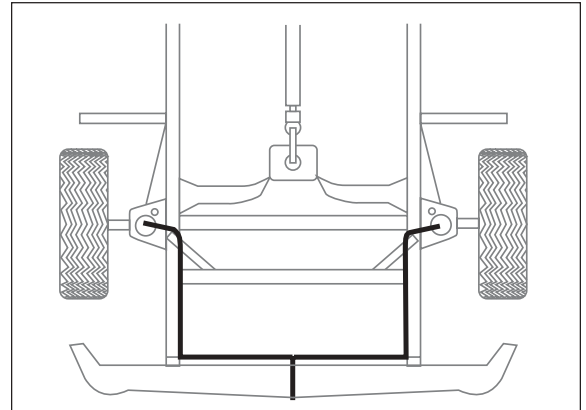

Figure 9

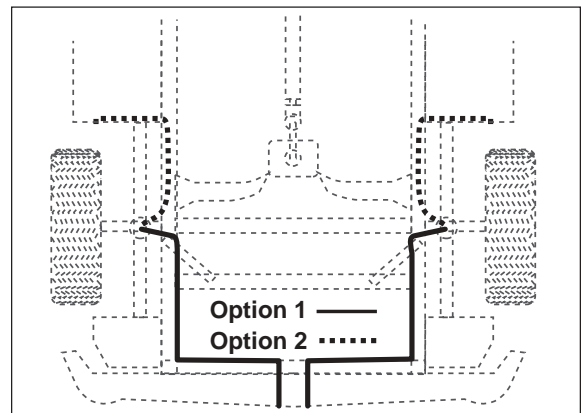

Figure 10

2. Dual Air Line routing:

*IMPORTANT: To prevent air line from melting, keep it at least 8" from the exhaust system.*

- a. Select a location for the inflation valves in the rocker panel flange, or rear bumper, insuring that each valve will be protected and accessible with an air hose (Figure 10).
- b. Determine and cut an adequate length of air line to reach from valve location to left side air cylinder. *CAUTION: Leave sufficient air line slack to prevent strain on valve stem during axle motions.*
- c. Insert the air line through the lower control arm and spacer.
- d. Slide air line clamp onto the cut air line.
- e. Push the air line onto the stem of the air spring, covering all the barbed section. With pliers slide the air line clamp forward until it fully covers barbed section (Figure 8).
- f. Repeat process for right side.
- g. Drill  $\frac{5}{16}$ " hole for inflating valves and mount as illustrated. Rubber washer is for outside weather seal (Figure 11).

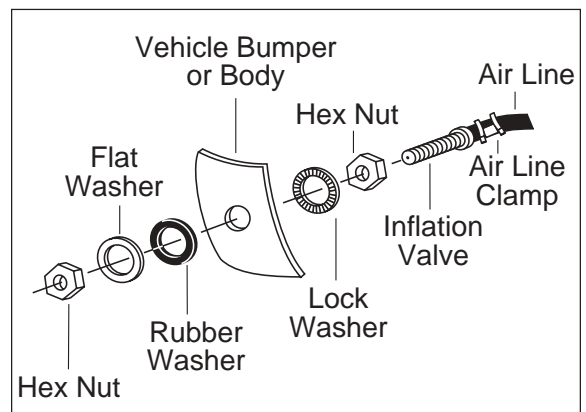

Figure 11

- h. Route air line along control arm and frame to inflation valve location and cut off excess.
- i. Slide a clamp onto the air line and push the air line over the fitting, covering all the barbs. With pliers slide the air line clamp forward until it fully covers the barbed section (Figure 7).
- j. Raise axle or lower body until air cylinders lightly touch upper spring seat and lower spacers.
- k. Check tail pipe clearance and insure that it is at least 2-3 inches from air cylinders. If heat shields are supplied, install them.

*CAUTION: Do not inflate air cylinders before reading the maintenance and operation tips.*

## Testing the Air Springs

1. Inflate the cylinders to 35 lbs of air pressure. Test for air leaks by applying a liquid solution of 1/5 dish soap to 4/5 water to all valve cores, fittings, and connections.
2. Lower the vehicle to the ground and deflate the air springs in 5 p.s.i. intervals to determine best ride and handling.
3. Recheck air pressure after 24 hours. A 2-4 p.s.i. loss after initial installation is normal. If pressure has dropped by more than 5 lbs, then retest for leaks with the soapy water solution.

Minimum Air Pressure
5 p.s.i.

Maximum Air Pressure
35 p.s.i.

*Failure to maintain minimum pressure will void the warranty.*

### **Maintenance**

1. Check air pressure weekly.
2. Always maintain at least a 5 p.s.i. air pressure chafing or coil pinch.
3. If a leak develops in the system, use a soapy water solution to check all air line connections and valve cores before removing the cylinder.

### **Operation**

1. Inflate the air springs to 35 p.s.i. before adding the payload. After vehicle is loaded, adjust the air pressure down to level the vehicle for ride comfort.
2. When carrying a payload, it will be useful to increase the tire pressure in proportion to any overload condition. A 2 p.s.i. increase above normal is recommended (do not exceed manufacturer's maximum) for each 100 lbs of load on the axle.



### ***Thank you for purchasing Air Lift Products***

Mailing Address:  
 AIR LIFT COMPANY  
 P.O. Box 80167  
 Lansing, MI 48908-0167

Street Address:  
 AIR LIFT COMPANY  
 2727 Snow Rd.  
 Lansing, MI 48917

Local Phone: (517) 322-2144

Fax: (517) 322-0240

<http://www.airliftcompany.com>

**For Technical Assistance call 1-800-248-0892, extension 2**

***“The Choice of the Professional Installer”***

Printed in the USA



# Product Use Information

## Frequently asked questions

**Q. Will installing air springs increase the weight ratings of a vehicle?**

No. Adding air springs will not change the weight ratings (GAWR, GCWR and/or GVWR) of a vehicle. Exceeding the GVWR is dangerous and voids the Air Lift warranty.

**Q. Is it necessary to keep air in the air springs at all time and how much pressure will they need?**

The minimum air pressure should be maintained at all times. The minimum air pressure keeps the air spring in shape, ensuring that it will move throughout its travel without rubbing or wearing on itself.

**Q. Is it necessary to add a compressor system to the air springs?**

No. Air pressure can be adjusted with any type of compressor as long as it can produce sufficient pressure to service the springs. Even a bicycle tire pump can be used, but it's a lot of work.

**Q. How long should air springs last?**

If the air springs are properly installed and maintained they can last indefinitely.

**Q. Will raising the vehicle on a hoist for service work damage the air springs?**

No. The vehicle can be lifted on a hoist for short-term service work such as tire rotation or oil changes. However, if the vehicle will be on the hoist for a prolonged period of time, support the axle with jack stands in order to take the tension off of the air springs.

## Tuning the air pressure

Pressure determination comes down to three things — level vehicle, ride comfort, and stability.

**1. Level vehicle**

If the vehicle's headlights are shining into the trees or the vehicle is leaning to one side, then it is not level (fig. 1). Raise the air pressure to correct either of these problems and level the vehicle.

**2. Ride comfort**

If the vehicle has a rough and harsh ride it may be due to either too much pressure or not enough (fig. 2). Try different pressures to determine the best ride comfort.

**3. Stability**

Stability translates into safety and should be the priority, meaning the driver may need to sacrifice a perfectly level and comfortable ride. Stability issues include roll control, bounce, dive during braking and sponginess (fig. 3). Tuning out these problems usually requires an increase in pressure.

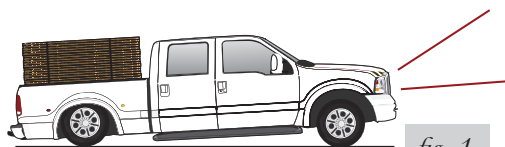

Bad headlight aim



Sway and body roll



Rough ride

### Guidelines for adding air:

1. Start with the vehicle level or slightly above.
2. When in doubt, always add air.
3. For motorhomes, start with 50-100 PSI in the rear because it can be safely assumed that it is heavily loaded.
4. If the front of the vehicle dives while braking, increase the pressure in the front air bags, if equipped.
5. If it is ever suspected that the air bags have bottomed out, increase the pressure (fig. 4).
6. Adjust the pressure up and down to find the best ride.
7. If the vehicle rocks and rolls, adjust the air pressure to reduce movement.
8. It may be necessary to maintain different pressures on each side of the vehicle. Loads such as water, fuel, and appliances will cause the vehicle to be heavier on one side (fig. 5). As much as a 50 PSI difference is not uncommon.

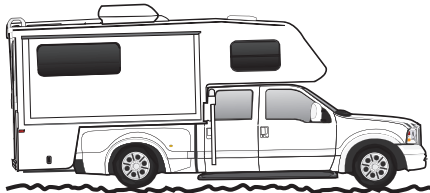

Bottoming out

fig. 4

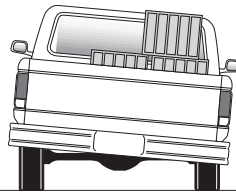

Unlevel

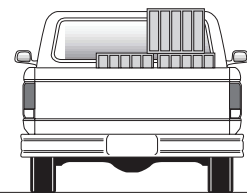

Level

fig. 5

## Warranty and Returns Policy

Air Lift Company warrants its products, for the time periods listed below, to the original retail purchaser against manufacturing defects when used on catalog-listed applications on cars, vans, light trucks and motorhomes under normal operating conditions for as long as Air Lift manufactures the product. The warranty does not apply to products that have been improperly applied, improperly installed, used in racing or off-road applications, used for commercial purposes, or which have not been maintained in accordance with installation instructions furnished with all products. The consumer will be responsible for removing (labor charges) the defective product from the vehicle and returning it, transportation costs prepaid, to the dealer from which it was purchased or to Air Lift Company for verification.

Air Lift will repair or replace, at its option, defective products or components. A minimum \$10.00 shipping and handling charge will apply to all warranty claims. Before returning any defective product, you must call Air Lift at (800) 248-0892 in the U.S. and Canada (elsewhere, (517) 322-2144) for a Returned Materials Authorization (RMA) number. Returns to Air Lift can be sent to: Air Lift Company • 2727 Snow Road • Lansing, MI • 48917.

Product failures resulting from abnormal use or misuse are excluded from this warranty. The loss of use of the product, loss of time, inconvenience, commercial loss or consequential damages is not covered. The consumer is responsible for installation/reinstallation (labor charges) of the product. Air Lift Company reserves the right to change the design of any product without assuming any obligation to modify any product previously manufactured.

This warranty gives you specific legal rights and you may also have other rights that vary from state-to-state. Some states do not allow limitations on how long an implied warranty lasts or allow the exclusion or limitation of incidental or consequential damages. The above limitation or exclusion may not apply to you. There are no warranties, expressed or implied including any implied warranties of merchantability and fitness, which extend beyond this warranty period. There are no warranties that extend beyond the description on the face hereof. Seller disclaims the implied warranty of merchantability. (Dated proof of purchase required.)

**Air Lift 1000** ..... Lifetime Limited  
**RideControl** ..... Lifetime Limited  
**SlamAir** ..... Lifetime Limited  
**LoadLifter 5000\*** ..... Lifetime Limited  
**EasyStreet Systems** ..... 1 Year Limited

**Load Controller (I)** ..... 2 Year Limited  
**Load Controller (II)** ..... 2 Year Limited  
**SmartAir** ..... 2 Year Limited  
**Wireless AIR**..... 2 Year Limited  
**Other Accessories**..... 2 Year Limited

*\*formerly SuperDuty*

**Thank you for purchasing Air Lift products! For technical support, please call (800) 248-0892.**  
 Air Lift Company • P.O. Box 80167, MI 48908-0167 • (517) 322-2144 • Fax: (517) 322-0240 • [www.airliftcompany.com](http://www.airliftcompany.com)

# TEMPLATE

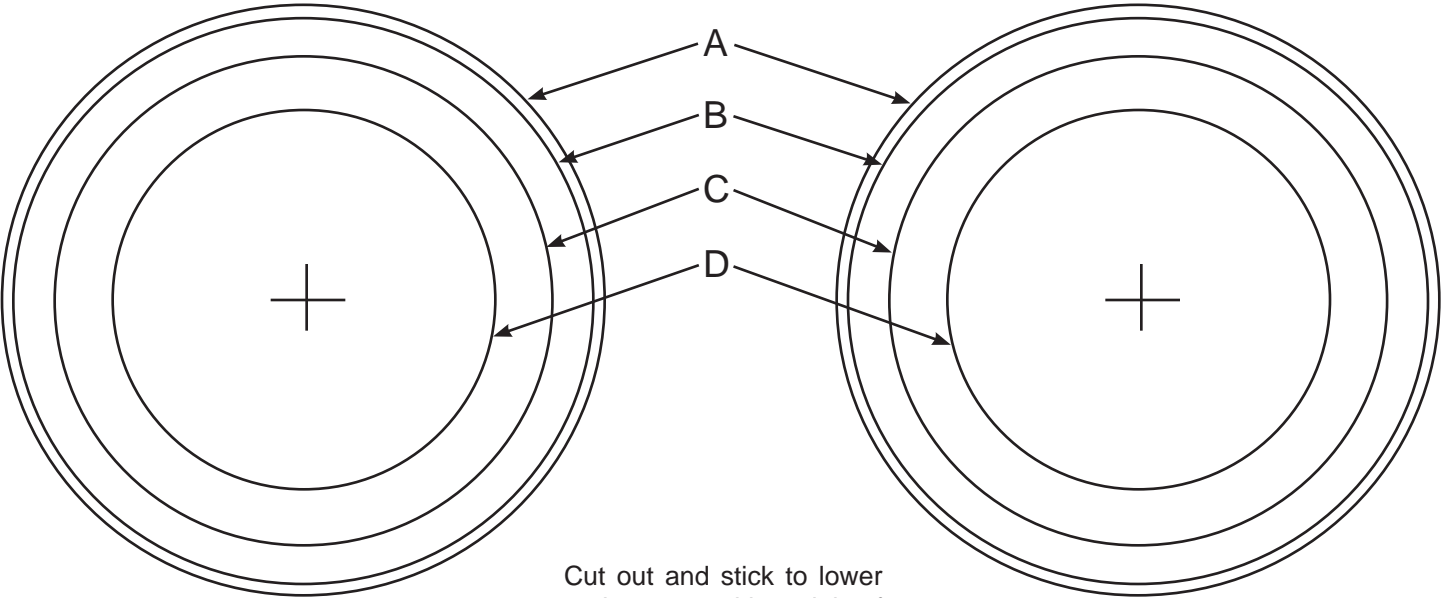

Cut out and stick to lower spring seat with a dab of grease.