

# LoadLIFTER 5000

by AIR LIFT®

## Kit 57250

*2001-2005 Chevy Silverado 1500HD*

*2001-2008 GMC Sierra 1500HD*

*1999-2004 Chevy Silverado/  
GMC Sierra 2500 3/4 Ton Pickup*



## INSTALLATION GUIDE

For maximum effectiveness and safety, please read these instructions completely before proceeding with installation.

*Failure to read these instructions can result in an incorrect installation.*



# TABLE OF CONTENTS

<b>Introduction</b> .....	<b>2</b>
Important Safety Notice .....	2
Notation Explanation .....	2
<b>Installation Diagram</b> .....	<b>3</b>
Hardware List .....	3
Tools List .....	3
<b>Installing the LoadLifter 5000 System</b> .....	<b>4</b>
Getting Started .....	4
Assembling the Air Spring Unit .....	5
Removing the Jounce Bumper .....	7
Attaching the Air Spring Assembly .....	7
Install the Other Air Spring .....	10
Installing the Air Lines .....	10
Installing the Heat Shield .....	11
Checking for Leaks .....	11
Fixing Leaks .....	11
<b>Before Operating</b> .....	<b>12</b>
Installation Checklist .....	12
Post-installation checklist .....	12
<b>Product Use, Maintenance and Servicing</b> .....	<b>12</b>
Suggested Driving Pressure and Maximum Air Pressure .....	12
Maintenance Guidelines .....	13
Troubleshooting Guide .....	13
Frequently Asked Questions .....	13
Tuning the Air Pressure .....	14
Guidelines for Adding Air .....	14
<b>Warranty and Returns Policy</b> .....	<b>15</b>
<b>Replacement Parts and Returns</b> .....	<b>16</b>

# Introduction

The purpose of this publication is to assist with the installation, maintenance and troubleshooting of the LoadLifter 5000 air spring kit. LoadLifter 5000 utilizes sturdy, reinforced, commercial grade single or double, depending on the kit, convolute bellows. The bellows are manufactured like a tire with layers of rubber and cords that control growth. LoadLifter 5000 kits are recommended for most 3/4 and 1 ton pickups and SUVs with leaf springs and provide up to 5,000 lbs. of load leveling support with air adjustability from 5-100 PSI. The kits are also used in motor home rear kits and some motor home fronts where leaf spring are used.

It is important to read and understand the entire installation guide before beginning installation or performing any maintenance, service or repair. The information here includes a hardware list, tool list, step-by-step installation information, maintenance guidelines and operating tips.

Air Lift Company reserves the right to make changes and improvements to its products and publications at any time. For the latest version of this manual, contact Air Lift Company at (800) 248-0892 or visit our website at [www.airliftcompany.com](http://www.airliftcompany.com).

## IMPORTANT SAFETY NOTICE

The installation of this kit does not alter the Gross Vehicle Weight Rating (GVWR) or payload of the vehicle. Check your vehicle's owner's manual and do not exceed the maximum load listed for your vehicle.

**Gross Vehicle Weight Rating:** The maximum allowable weight of the fully loaded vehicle (including passengers and cargo). This number — along with other weight limits, as well as tire, rim size and inflation pressure data — is shown on the vehicle's Safety Compliance Certification Label.

**Payload:** The combined, maximum allowable weight of cargo and passengers that the truck is designed to carry. Payload is GVWR minus the Base Curb Weight.

## NOTATION EXPLANATION

Hazard notations appear in various locations in this publication. Information which is highlighted by one of these notations must be observed to help minimize risk of personal injury or possible improper installation which may render the vehicle unsafe. Notes are used to help emphasize areas of procedural importance and provide helpful suggestions. The following definitions explain the use of these notations as they appear throughout this guide.

### DANGER

INDICATES IMMEDIATE HAZARDS WHICH WILL RESULT IN SEVERE PERSONAL INJURY OR DEATH.

### WARNING

INDICATES HAZARDS OR UNSAFE PRACTICES WHICH COULD RESULT IN SEVERE PERSONAL INJURY OR DEATH.

### CAUTION

INDICATES HAZARDS OR UNSAFE PRACTICES WHICH COULD RESULT IN DAMAGE TO THE MACHINE OR MINOR PERSONAL INJURY.

## NOTE

*Indicates a procedure, practice or hint which is important to highlight.*

# Installation Diagram

## HARDWARE LIST

Item	Description	Quantity
A	Air Springs	2
B	Roll Plates	4
C	Upper Bracket	2
E	Retaining Brackets	4
F	Lower Brackets	2
G	Heat Shield Kit	1
I	3/8-24 x 7/8" Hex Head Bolts	8
J	3/8-16 x 2" Hex Head Bolts	4
K	5/16" Clinch Bolt (Driver's Side Only)	1
L	3/8-16 Lock Nut	4
M	Flat Washer	21
N	5/16" Lock Nut (Driver's Side Only)	1
O	3/8" Whiz Nut	4
P	Hose Clip (Driver's Side Only)	1
S	Lock Washers	8
T	90° Swivel Fitting	2
AA	Air Line Assembly	1
BB	Tie Strap	6
CC	Valve Caps	2
DD	5/16" Flat Washers	2
EE	Rubber Washer	2
FF	Star Washer	2
GG	5/16" Hex Nut	4
HH	Thermal Sleeve	2
JJ	3/8-16 X 7/8" Hex Head Bolts	4

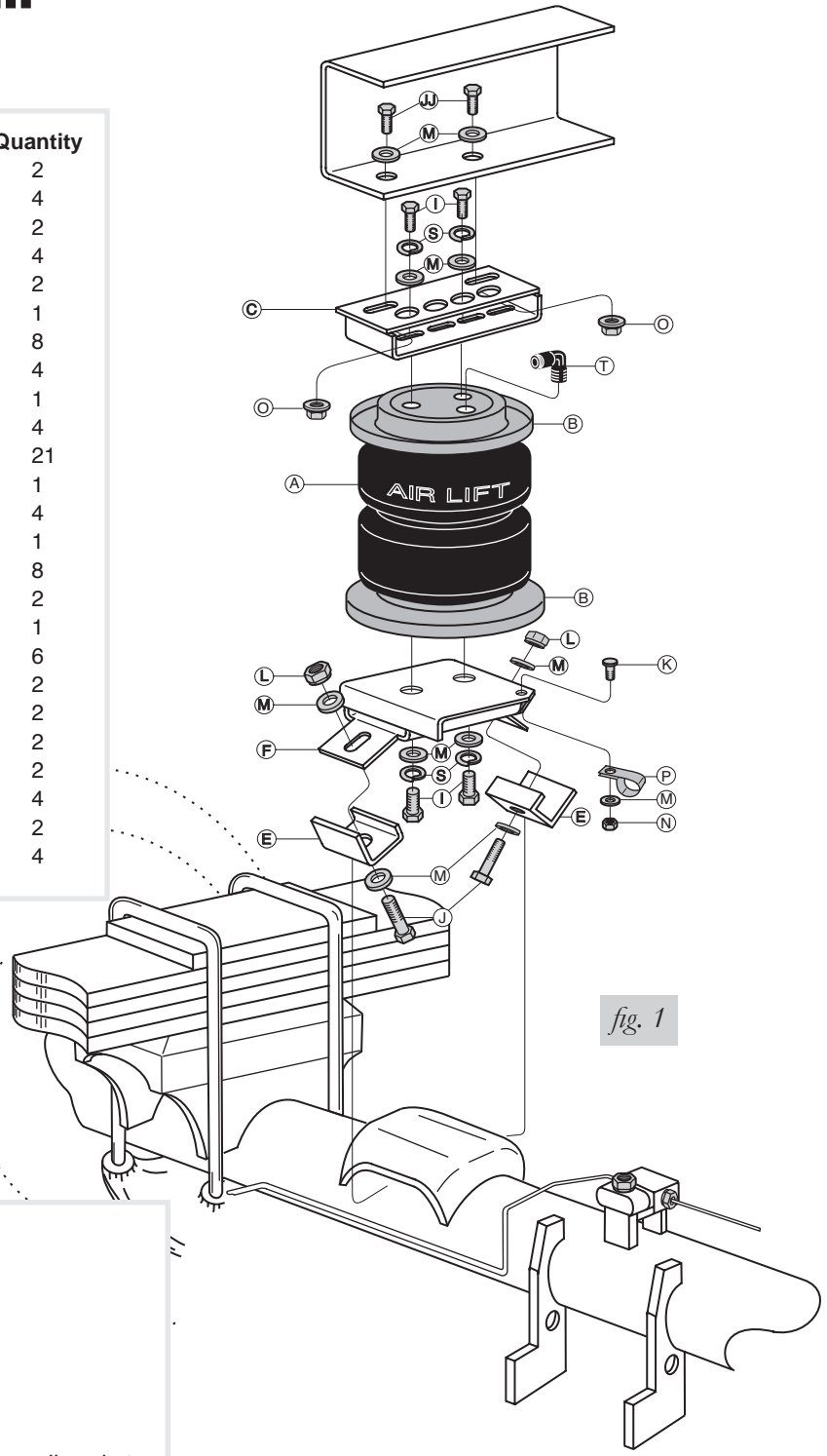

## TOOLS LIST

Description
Jack
Jack Stands or hoist
Safety glasses
Air compressor or compressed air source
Spray bottle with dish soap/water solution
9/16" open-end box wrenches
Crescent Wrench
Ratchet with 15mm, 7/16", 9/16" and 1/2" deep well sockets
3/8" & 5/16" drill bits (very sharp)
Heavy Duty Drill
Torque Wrench
Hose cutter, razor blade, or sharp knife
3/4" Wrench

**STOP!** Missing or damaged parts? Call Air Lift customer service at (800) 248-0892 for a replacement part.

# Installing the LoadLifter5000 System

**IMPORTANT:** Your vehicle may be equipped with a rear brake proportioning valve. Any type of load assist product could affect brake performance. We recommend that you check with your dealer before installing this type of product. If your vehicle DOES NOT have a rear brake proportioning valve or is equipped with an anti-lock type brake system, installation of a load assist product will have NO EFFECT ON BRAKE SYSTEM PERFORMANCE.

**IMPORTANT:** Failure to maintain correct minimum pressure (or pressure proportional to load), bottoming out, overextension, or rubbing against another component will void the warranty.

## CAUTION

COMPRESSED AIR CAN CAUSE INJURY AND DAMAGE TO THE VEHICLE AND PARTS IF IT IS NOT HANDLED PROPERLY. FOR YOUR SAFETY, DO NOT TRY TO INFLATE THE AIR SPRINGS UNTIL THEY HAVE BEEN PROPERLY SECURED TO THE VEHICLE.

## GETTING STARTED

1. Determine the Normal Ride Height. The Normal Ride Height is the distance between the bottom edge of the wheel-well and the center of the hub with the vehicle in the "as delivered" condition. In some cases, Normal Ride Height is not perfectly level.
  - a. Remove unusual loads and examine your vehicle from the side to ensure it is on a level surface.
  - b. If necessary (in cases where your leaf springs are sagging badly), use a jack to raise the rear end so that the vehicle achieves the original "as delivered" ride height.



fig. 2

2. Measure the distance between the center of the hub and the bottom edge of the wheel well (see fig. 3). This is the Normal Ride Height. Enter the measurement below:

NORMAL

RIDE HEIGHT: \_\_\_\_\_ inches



fig. 3

### ASSEMBLING THE AIR SPRING UNIT

1. Set a roll plate (B) on both ends of the air spring (A). The radiused (rounded) edge of the roll plate will be towards the air spring, so that the air spring is “seated” in both roll plates (Fig. 4).

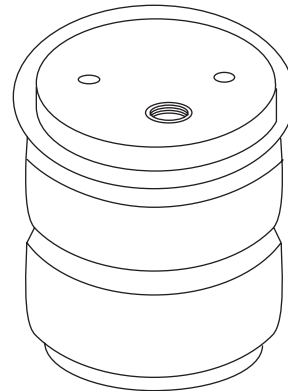

fig. 4

2. Attach the upper brackets (C) to the air springs with two 3/8-24x7/8” hex head bolts (I), lockwashers(S) and flat washers (M). Leave loose at this time (Fig. 5).

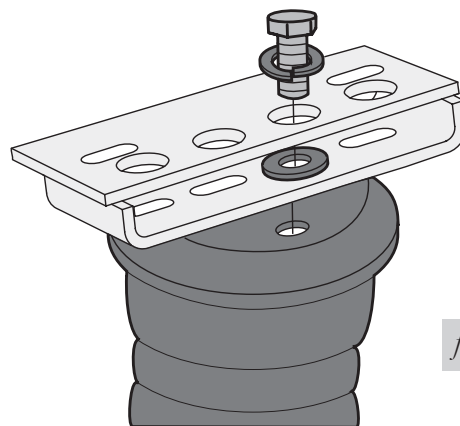
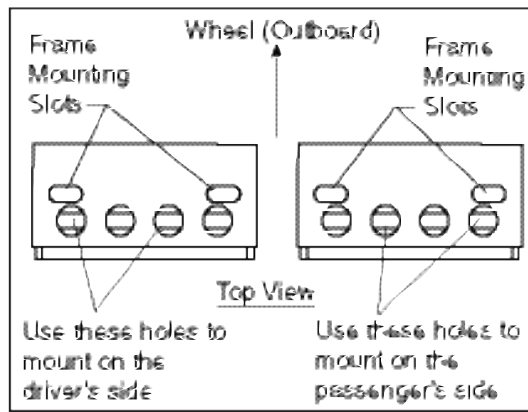

fig. 5

CAUTION

#### NOTE

*It will be necessary to use the correct holes for driver and passenger side mounting. See diagram to correctly index the bellows and the upper bracket (Fig. 6).*

*fig. 6*

**DRIVERS SIDE ONLY** - Insert 5/16 clinch bolt (K) into the small hole of the lower bracket before attaching the lower bracket to the air spring. Supporting the lower bracket will ease installation of the clinch bolt. Use a hammer to drive the bolt into the hole in the lower bracket (Fig. 7).

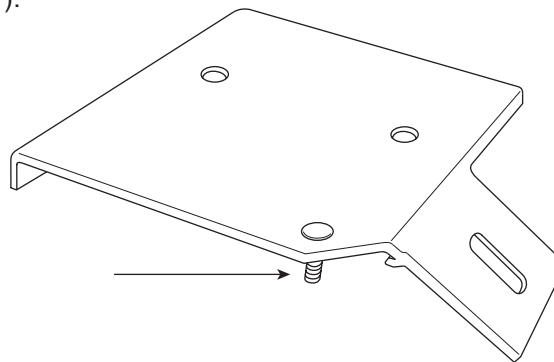
*fig. 7*

3. The lower bracket must be attached with the small hole in the lower bracket on the same side as the air port in the air spring.

**NOTE**

*Be sure to install the assembly with the clinch bolt on the driver side. Refer to diagram (Fig. 7) on page 6.*

4. Attach the air spring to the lower bracket (figs. 8 & 9). Secure the lower bracket (F) to the air spring (A) with two 3/8-24x7/8" hex head bolts (I), lockwashers (S) and flat washers (M). (fig. 9)
5. Torque to 20 ft. lbs. It may be helpful to use a socket to install the mounting hardware.

**CAUTION**

**DO NOT CROSS THREAD THE BOLT.**

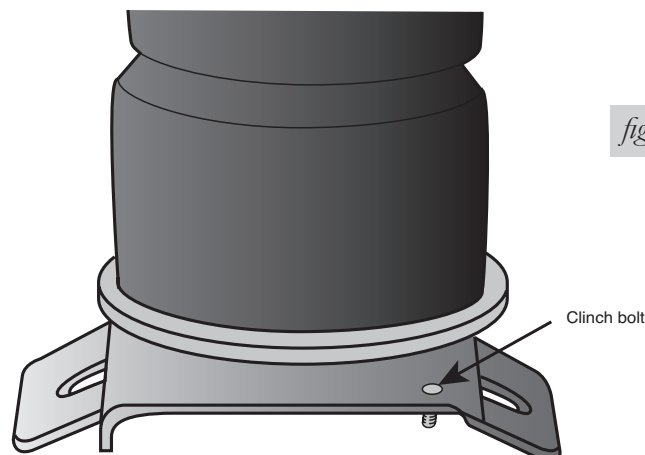
*fig. 8*



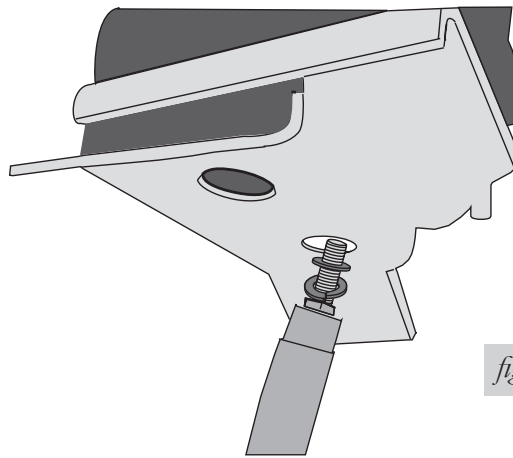

fig. 9

## REMOVING THE JOUNCE BUMPER

1. Using a 15mm Socket, remove the jounce bumper from the frame rail (Fig. 10).

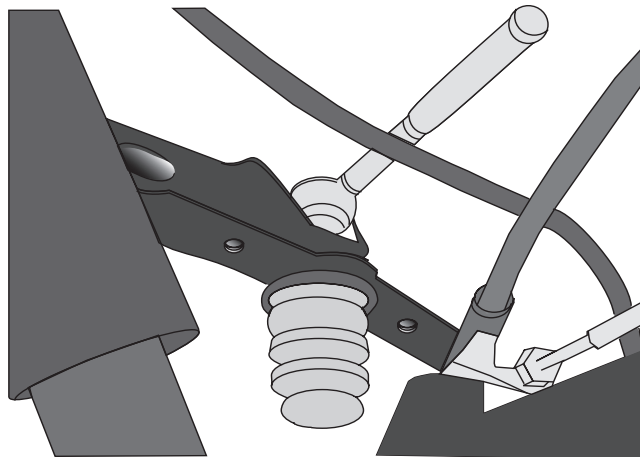

fig. 10

2. The style of jounce bumper will vary depending on the model of the truck.
3. On some models the jounce bumper may be attached to the frame with a bracket.
4. Remove the entire jounce bumper bracket and the jounce bumper from the frame rail (Fig. 11).

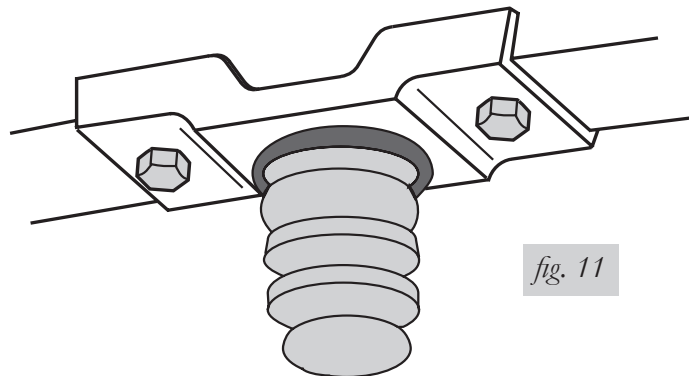

fig. 11

## ATTACHING THE AIR SPRING ASSEMBLY

1. Set assembly on the axle with the air port on top of the bellows toward the inside of the frame rail (Figure 1).

**NOTE**

Reference *Assembling the Air Spring Unit (page 5), Attaching the Upper Bracket, for driver side and passenger side assemblies.*

2. Set whiz nut (O) up inside of the upper bracket (Fig. 12 & 13) with flange up (Fig. 12).
3. Hold in place with an open end 9/16" wrench.

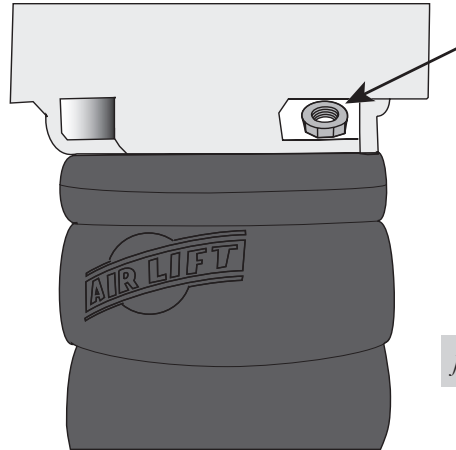
*fig. 12*

4. Put 3/8"x7/8" hex head bolts (I) with flat washers (M) down through the existing jounce bumper hole from the inside of the frame, and attach to the whiz nuts (Fig. 13). Leave loose for adjustment later.

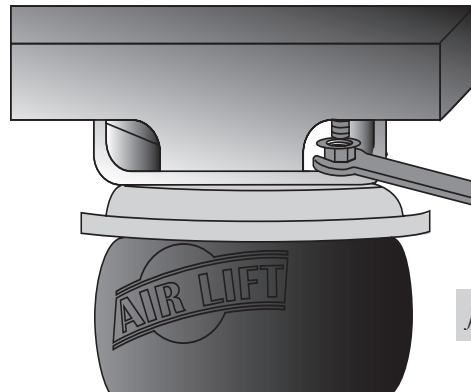
*fig. 13*

5. Secure the lower bracket to the jounce bumper strike pad using the retaining bracket (E), 3/8"x2" hex head bolt (J), flat washers (M) and 3/8" lock nut (L) (Fig. 14).

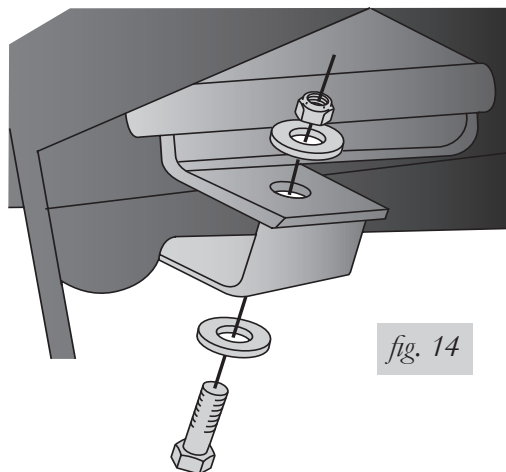
*fig. 14*

6. The short leg of the retaining bracket must be under the edge of the jounce bumper strike pad.
7. Tighten evenly front to back to keep the lower bracket flat and centered on the jounce bumper pad.
8. Center the upper bracket, so the bolts are in the center of the slots (Fig. 15).

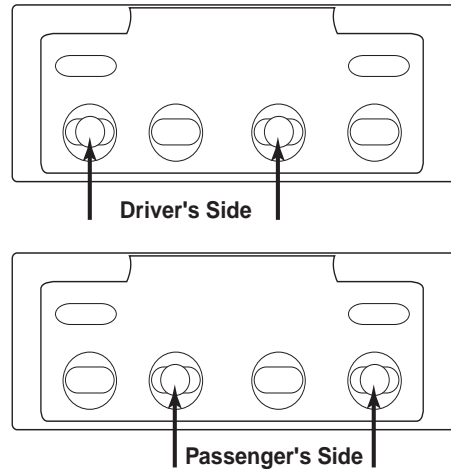

fig. 15

9. Adjust bellows at top so bellows is perpendicular to both upper and lower brackets.
10. Tighten both bellows to top bracket mounting bolts (Fig. 16).

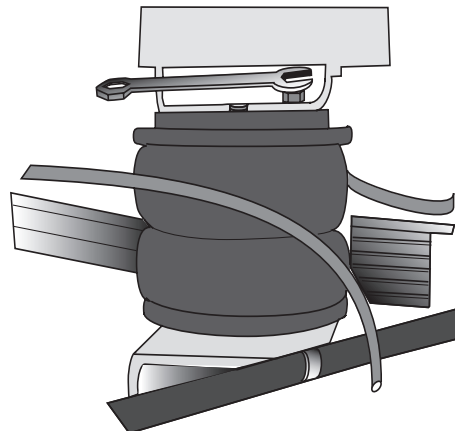
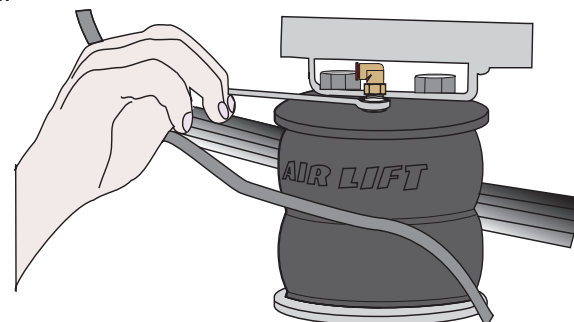

fig. 16

11. Tighten bracket to frame mounting hardware.
12. Install the swivel air fitting (T) into the top of the air spring (A). This fitting is pre-coated with sealant. Finger-tight plus two full turns with an open-end wrench will seal the fitting (Fig. 17).
13. Use a 7/16" open end wrench being careful to tighten on the metal hex nut only. DO NOT OVERTIGHTEN.

CAUTION

fig. 17



## DRIVERS SIDE ONLY - SECURE BRAKE LINE

1. Slide the provided clip (P) onto the rubber coated brake line (Fig. 18). Secure the clip (P) to the clinch bolt already installed on the lower bracket (F) with a flat washer (M) and 5/16" nut (N).



fig. 18

### CAUTION

BE SURE THE CLIP IS UNDER THE LOWER BRACKET (FIG. 19).

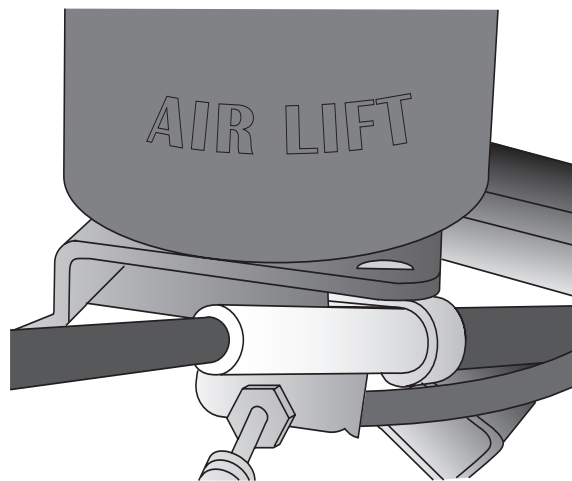

fig. 19

## INSTALL THE OTHER AIR SPRING

1. You have now completed the installation for one air spring. Repeat the steps on pages 4 through 10 for the other side of the vehicle before you proceed to "Installing the Air Lines".

## INSTALLING THE AIR LINES

1. Choose a convenient location for mounting the inflation valves. Popular locations for the inflation valve are:
  - a. The wheel well flanges
  - b. The license plate recess in bumper
  - c. Under the gas cap access door
  - d. Through the license plate

### NOTE

*Whatever the chosen location, make sure there is enough clearance around the inflation valves for an air chuck.*

2. Drill two 5/16" holes to install the inflation valves.
3. Cut the air line assembly in two equal lengths.

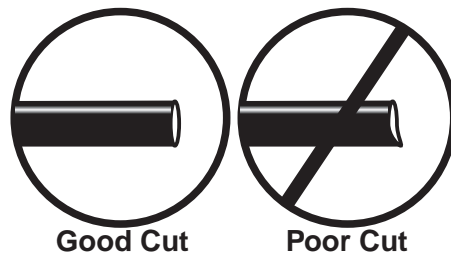

fig. 20

**CAUTION**

WHEN CUTTING OR TRIMMING THE AIR LINE, USE A HOSE CUTTER, A RAZOR BLADE, OR A SHARP KNIFE. A CLEAN, SQUARE CUT WILL ENSURE AGAINST LEAKS. DO NOT USE WIRE CUTTERS OR SCISSORS TO CUT THE AIR LINE. THESE TOOLS MAY FLATTEN OR CRIMP THE AIR LINE CAUSING IT TO LEAK AROUND THE O-RING SEAL INSIDE THE ELBOW FITTING (FIG. 20).

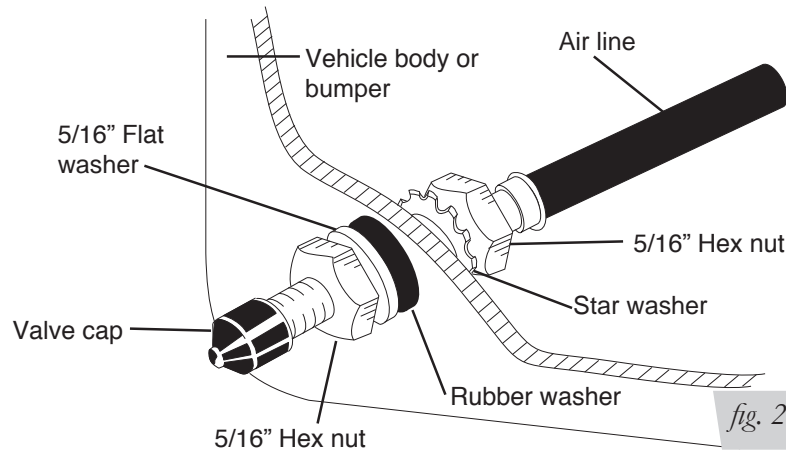

fig. 21

4. Place a 5/16" nut and star washer on the air valve. Leave enough of the inflation valve in front of the nut to extend through the hole and have room for the rubber washer, flat washer, and 5/16" nut and cap. There should be enough valve exposed after installation—approximately 1/2"— to easily apply a pressure gauge or an air chuck (fig. 21).
5. Push the inflation valve through the hole and use the rubber washer, flat washer, and another 5/16" nut to secure it in place. Tighten the nuts to secure the assembly.
6. Route the air line along the frame to the air fitting on the air spring (fig. 22). Keep AT LEAST 6" of clearance between the air line and heat sources, such as the exhaust pipes, muffler, or catalytic converter. Avoid sharp bends and edges. Use the plastic tie straps to secure the air line to fixed, non-moving points along the chassis. Be sure that the tie straps are tight, but do not pinch the air line. Leave at least 2" of slack to allow for any movement that might pull on the air line (fig. 22).

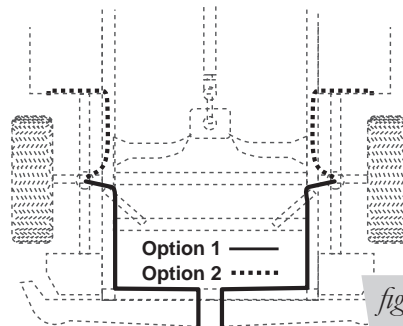

fig. 22

7. Cut off the air line, leaving approximately 12" of extra air line. A clean square cut will ensure against leaks. Insert the air line into the air fitting. This is a push-to-connect

fitting. Simply push the air line into the 90° swivel fitting until it bottoms out (9/16" of air line should be in the fitting).

8. Install the minimum/maximum air pressure decal in a highly visible location. We suggest placing the decal on the driver-side window, just above the door handle.

## INSTALLING THE HEAT SHIELD

1. Bend tabs to provide a 1/2" dead air space between exhaust pipe and heat shield (fig. 23).
2. Attach the heat shield to the exhaust pipe using the clamps. Bend the heat shield for maximum clearance to the air spring (fig. 23).

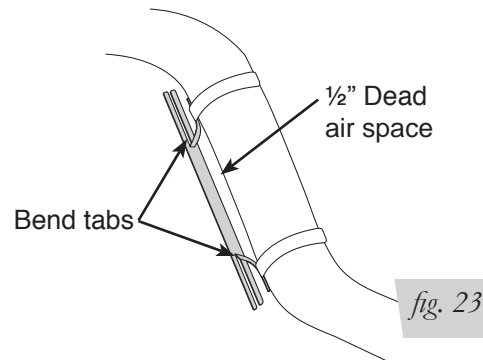

## CHECKING FOR LEAKS

1. Inflate the air spring to 30 PSI.
2. Spray all connections and the inflation valves with a solution of 1/5 liquid dish soap and 4/5 water. Spot leaks easily by looking for bubbles in the soapy water.
3. After the test, deflate the springs to the minimum pressure required to restore the system to normal ride height. Do not deflate to lower than 5 PSI.
4. Check the air pressure again after 24 hours. A 2 - 4 PSI loss after initial installation is normal. Retest for leaks if the loss is more than 5 lbs.

## FIXING LEAKS

1. If there is a problem with the swivel fitting:
  - a. Check the air line connection by deflating the spring and removing the line by pulling the collar against the fitting and pulling firmly on the air line. Trim 1" off the end of the air line. Be sure the cut is clean and square (see fig. 20). Reinsert the air line into the push-to-connect fitting.
  - b. Check the threaded connection by tightening the swivel fitting another 1/2 turn. If it still leaks, deflate the air spring, remove the fitting, and re-coat the threads with thread sealant. Reinstall by hand tightening as much as possible and then use a wrench for an additional two turns.
2. If there is a problem with the inflation valve:
  - a. Check the valve core by tightening it with a valve core tool.
  - b. Check the air line by removing the air line from the barbed type fitting. Cut the air line off a few inches in front of the fitting and use a pair of pliers or vice grips to pull/twist the air line off of the fitting.

### CAUTION

DO NOT CUT OFF THE AIR LINE COMPLETELY AS THIS WILL USUALLY NICK THE BARB AND RENDER THE FITTING USELESS.

3. If the preceding steps have not resolved the problem, call Air Lift customer service at (800) 248-0892.

# Before Operating

## INSTALLATION CHECKLIST (To be completed by installer)

- Clearance test — Inflate the air springs to 60 PSI and ensure there is at least ½” clearance around each bellow, away from anything that might rub against them. Be sure to check the tire, brake drum, frame, shock absorbers and brake cables.
- Leak test before road test — Inflate the air springs to 60 PSI, check all connections for leaks with a soapy water solution. See page 12 for tips on how to spot leaks. All leaks must be eliminated before the vehicle is road tested.
- Heat test — Be sure there is sufficient clearance from any heat sources — at least 6” for air springs and air lines. If a heat shield was included in the kit, install it. If there is no heat shield, but one is required, call (800) 248-0892.
- Fastener test — Recheck all bolts for proper torque. Axle straps carriage bolt lock nuts should be torqued to 16 ft/lbs. Re-torque after 100 miles.
- Road test — The vehicle should be road tested after the preceding tests. Inflate the air springs to 25 PSI (50 PSI if the vehicle is loaded). Drive the vehicle 10 miles and recheck for clearance, loose fasteners and air leaks.
- Operating instructions — If professionally installed, the installer should review the Product Use, Maintenance and Servicing section on page 13 with the owner. Be sure to provide the owner with all of the paperwork which came with the kit.

**Technician’s Signature** \_\_\_\_\_

**Date** \_\_\_\_\_

## POST-INSTALLATION CHECKLIST

- Overnight leak down test — Recheck air pressure after the vehicle has been used for 24 hours. If the pressure has dropped more than 5 PSI, then there is a leak that must be fixed. Either fix the leak yourself or return to the installer for service.
- Air pressure requirements — I understand the air pressure requirements of my air spring system. Regardless of load, the air pressure should always be adjusted to maintain ride height at all times.
- Thirty day or 500 mile test — I understand that I must recheck the air spring system after 30 days or 500 miles, whichever comes first. If any part shows signs of rubbing or abrasion, the source should be identified and moved, if possible. If it is not possible to relocate the cause of the abrasion, the air spring may need to be remounted. If professionally installed, the installer should be consulted. Check all fasteners for tightness.

# Product Use, Maintenance and Servicing

Suggested Driving Pressure	Maximum Air Pressure
5 PSI	100 PSI
FAILURE TO MAINTAIN CORRECT MINIMUM PRESSURE (OR PRESSURE PROPORTIONAL TO LOAD), BOTTOMING OUT, OVER-EXTENSION OR RUBBING AGAINST ANOTHER COMPONENT WILL VOID THE WARRANTY.	

## MAINTENANCE GUIDELINES

### NOTE

*By following the steps below, vehicle owners will obtain the longest life and best results from their air springs.*

1. Check the air pressure weekly.
2. Always maintain normal ride height. Never inflate beyond 100 PSI.
3. If you develop an air leak in the system, use a soapy water solution (1/5 liquid dish soap and 4/5 water) to check all air line connections and the inflation valve core before deflating and removing the air spring.

### CAUTION

FOR YOUR SAFETY AND TO PREVENT POSSIBLE DAMAGE TO YOUR VEHICLE, DO NOT EXCEED MAXIMUM GROSS VEHICLE WEIGHT RATING (GVWR), AS INDICATED BY THE VEHICLE MANUFACTURER. ALTHOUGH YOUR AIR SPRINGS ARE RATED AT A MAXIMUM INFLATION PRESSURE OF 100 P.S.I., THE AIR PRESSURE ACTUALLY NEEDED IS DEPENDANT ON YOUR LOAD AND GVWR.

4. Loaded vehicles require at least 25 PSI or more. A “loaded vehicle” refers to a vehicle with a heavy bed load, a trailer, or both. As discussed above, never exceed GVWR, regardless of air spring, air pressure, or other load assist. The springs in this kit will support approximately 40 lbs. of load (combined on both springs) for each 1 PSI of pressure. The required air pressure will vary depending on the state of the original suspension. Operating the vehicle below the minimum air spring pressure will void the Air Lift warranty.
5. When increasing load, always adjust the air pressure to maintain the normal ride height. Increase or decrease pressure from the system as necessary to attain normal ride height for optimal ride and handling. Remember that loads carried behind the axle (including tongue loads) require more leveling force (pressure) than those carried directly over the axle.
6. Always add air to springs in small quantities, checking the pressure frequently.
7. Should it become necessary to raise the vehicle by the frame, make sure the system is at minimum pressure (5 PSI) to reduce the tension on the suspension/brake components. Use of on board leveling systems do not require deflation or disconnection.
8. Periodically check the air spring system fasteners for tightness. Also, check the air springs for any signs of rubbing. Realign if necessary.
9. On occasion, give the air springs a hard spray with a garden hose in order to remove mud, sand, gravel or other abrasive debris.

## TROUBLESHOOTING GUIDE

1. Leak test the air line connections, the threaded connection into the air spring, and all fittings in the control system.
2. Inspect the air lines to be sure none are pinched. Tie straps may be too tight. Loosen or replace the strap and replace leaking components.
3. Inspect the air line for holes and cracks. Replace as needed.
4. Look for a kink or fold in the air line. Reroute as needed.

If the preceding steps do not solve the problem, it is possibly caused by a failed air spring — either a factory defect or an operating problem. Please call Air Lift at (800) 248-0892 for assistance.

## FREQUENTLY ASKED QUESTIONS

### **Q. Will installing air springs increase the weight ratings of a vehicle?**

No. Adding air springs will not change the weight ratings (GAWR, GCWR and/or GVWR) of a vehicle. Exceeding the GVWR is dangerous and voids the Air Lift warranty.



**Q. Is it necessary to keep air in the air springs at all times and how much pressure will they need?**

The minimum air pressure should be maintained at all times. The minimum air pressure keeps the air spring in shape, ensuring that it will move throughout its travel without rubbing or wearing on itself.

**Q. Is it necessary to add a compressor system to the air springs?**

No. Air pressure can be adjusted with any type of compressor as long as it can produce sufficient pressure to service the springs. Even a bicycle tire pump can be used, but it's a lot of work.

**Q. How long should air springs last?**

If the air springs are properly installed and maintained they can last indefinitely.

**Q. Will raising the vehicle on a hoist for service work damage the air springs?**

No. The vehicle can be lifted on a hoist for short-term service work such as tire rotation or oil changes. However, if the vehicle will be on the hoist for a prolonged period of time, support the axle with jack stands in order to take the tension off of the air springs.

## TUNING THE AIR PRESSURE

Pressure determination comes down to three things — level vehicle, ride comfort, and stability.

### 1. Level vehicle

If the vehicle's headlights are shining into the trees or the vehicle is leaning to one side, then it is not level (fig. 24). Raise the air pressure to correct either of these problems and level the vehicle.

### 2. Ride comfort

If the vehicle has a rough and harsh ride it may be due to either too much pressure or not enough (fig. 25). Try different pressures to determine the best ride comfort.

### 3. Stability

Stability translates into safety and should be the priority, meaning the driver may need to sacrifice a perfectly level and comfortable ride. Stability issues include roll control, bounce, dive during braking and sponginess (fig. 26). Tuning out these problems usually requires an increase in pressure.



Sway and body roll

## GUIDELINES FOR ADDING AIR

1. Start with the vehicle level or slightly above.
2. When in doubt, always add air.
3. For motorhomes, start with 50-100 PSI in the rear because it can be safely assumed that it is heavily loaded.
4. If the front of the vehicle dives while braking, increase the pressure in the front air bags, if equipped.

5. If it is ever suspected that the air bags have bottomed out, increase the pressure (fig. 27).
6. Adjust the pressure up and down to find the best ride.
7. If the vehicle rocks and rolls, adjust the air pressure to reduce movement.
8. It may be necessary to maintain different pressures on each side of the vehicle. Loads such as water, fuel, and appliances will cause the vehicle to be heavier on one side (fig. 28). As much as a 50 PSI difference is not uncommon.

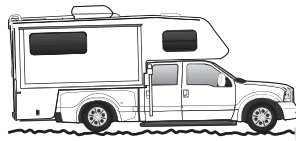

Bottoming out

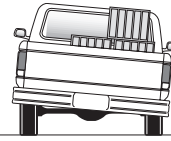
*fig. 27*

Unlevel

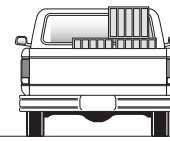

Level

*fig. 28*

## Warranty and Returns Policy

Air Lift Company warrants its products, for the time periods listed below, to the original retail purchaser against manufacturing defects when used on catalog-listed applications on cars, vans, light trucks and motorhomes under normal operating conditions for as long as Air Lift manufactures the product. The warranty does not apply to products that have been improperly applied, improperly installed, used in racing or off-road applications, used for commercial purposes, or which have not been maintained in accordance with installation instructions furnished with all products. The consumer will be responsible for removing (labor charges) the defective product from the vehicle and returning it, transportation costs prepaid, to the dealer from which it was purchased or to Air Lift Company for verification.

Air Lift will repair or replace, at its option, defective products or components. A minimum \$10.00 shipping and handling charge will apply to all warranty claims. Before returning any defective product, you must call Air Lift at (800) 248-0892 in the U.S. and Canada (elsewhere, (517) 322-2144) for a Returned Materials Authorization (RMA) number. Returns to Air Lift can be sent to: Air Lift Company • 2727 Snow Road • Lansing, MI • 48917.

Product failures resulting from abnormal use or misuse are excluded from this warranty. The loss of use of the product, loss of time, inconvenience, commercial loss or consequential damages is not covered. The consumer is responsible for installation/reinstallation (labor charges) of the product. Air Lift Company reserves the right to change the design of any product without assuming any obligation to modify any product previously manufactured.

This warranty gives you specific legal rights and you may also have other rights that vary from state-to-state. Some states do not allow limitations on how long an implied warranty lasts or allow the exclusion or limitation of incidental or consequential damages. The above limitation or exclusion may not apply to you. There are no warranties, expressed or implied including any implied warranties of merchantability and fitness, which extend beyond this warranty period. There are no warranties that extend beyond the description on the face hereof. Seller disclaims the implied warranty of merchantability. (Dated proof of purchase required.)

<b>Air Lift 1000</b> .....	<b>Lifetime Limited</b>	<b>LoadController/Dual</b> .....	<b>2 Year Limited</b>
<b>RideControl</b> .....	<b>Lifetime Limited</b>	<b>Load Controller (I)</b> .....	<b>2 Year Limited</b>
<b>LoadLifter 5000*</b> .....	<b>Lifetime Limited</b>	<b>Load Controller (II)</b> .....	<b>2 Year Limited</b>
<b>SlamAir</b> .....	<b>Lifetime Limited</b>	<b>SmartAir</b> .....	<b>2 Year Limited</b>
<b>AirCell</b> .....	<b>Lifetime Limited</b>	<b>Wireless AIR</b> .....	<b>2 Year Limited</b>
<b>Air Lift Performance**</b> .....	<b>1 Year Limited</b>	<b>WirelessONE</b> .....	<b>2 Year Limited</b>
<b>LoadController/Single</b> .....	<b>2 Year Limited</b>	<b>Other Accessories</b> .....	<b>2 Year Limited</b>

*\*formerly SuperDuty*

*\*\*formerly LifeSTYLE & Performance*

---

# Replacement Information

If you need replacement parts, contact the local dealer or call Air Lift customer service at (800) 248-0892. Most parts are immediately available and can be shipped the same day.

**Contact Air Lift Company customer service at (800) 248-0892 first if:**

- Parts are missing from the kit.
- Need technical assistance on installation or operation.
- Broken or defective parts in the kit.
- Wrong parts in the kit.
- Have a warranty claim or question.

**Contact the retailer where the kit was purchased:**

- If it is necessary to return or exchange the kit for any reason.
- If there is a problem with shipping if shipped from the retailer.
- If there is a problem with the price.

# Contact Information

If you have any questions, comments or need technical assistance contact our customer service department by calling (800) 248-0892, Monday through Friday, 8 a.m. to 7 p.m. Eastern Time. For calls from outside the USA or Canada, our local number is (517) 322-2144.

For inquiries by mail, our address is PO Box 80167, Lansing, MI 48908-0167. Our shipping address for returns is 2727 Snow Road, Lansing, MI 48917.

You may also contact us anytime by e-mail at [sales@airliftcompany.com](mailto:sales@airliftcompany.com) or on the web at [www.airliftcompany.com](http://www.airliftcompany.com).

## Need Help?

Contact our customer service department by calling (800) 248-0892, Monday through Friday, 8 a.m. to 7 p.m. Eastern Time. For calls from outside the USA or Canada, our local number is (517) 322-2144.

**Register your warranty online at  
[www.airliftcompany.com/warranty](http://www.airliftcompany.com/warranty)**



*Thank you for purchasing Air Lift products — the professional installer's choice!*

Air Lift Company • 2727 Snow Road • Lansing, MI 48917 or PO Box 80167 • Lansing, MI 48908-0167  
Toll Free (800) 248-0892 • Local (517) 322-2144 • Fax (517) 322-0240 • [www.airliftcompany.com](http://www.airliftcompany.com)

Printed in  
the USA