

Air Lift[™]

PERFORMANCE

Kits 75563, 75564, 75567 & 75568

Universal Sleeve-Over-Strut

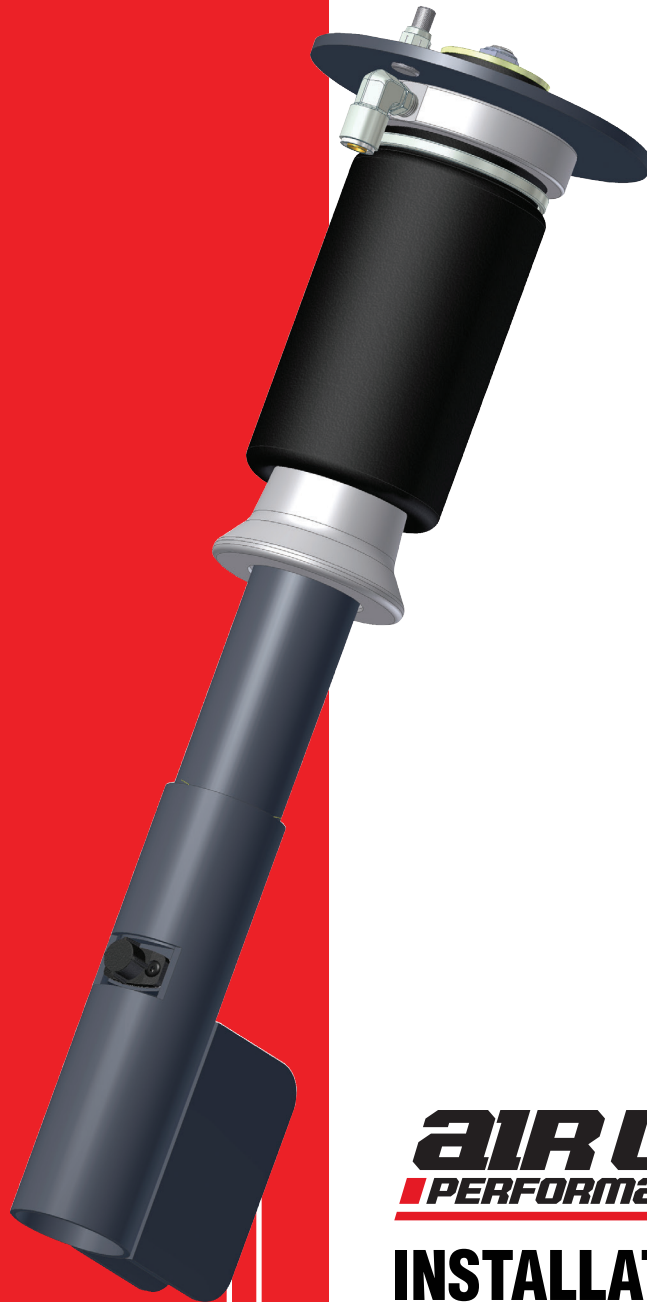

AIR LIFT

PERFORMANCE[™]

INSTALLATION GUIDE

**NOTE: THIS KIT IS SOLD
WITHOUT A WARRANTY.**

For maximum effectiveness and safety, please read these instructions completely before proceeding with installation.

Failure to read these instructions can result in an incorrect installation.

TABLE OF CONTENTS

Introduction	2
Notation Explanation	2
Important Safety Notices	2
Installation Diagram	3
Hardware List	3
Installing the Universal Sleeve Over Strut Kit	4
Preparing the Vehicle	4
Strut Removal	4
Determining Mounting Height	5
Painting	9
Sleeve Over Strut Install	9
Before Operating	10
Installation Checklist	11
Post-Installation Checklist	11
Product Use, Maintenance and Servicing	12
Suggested Driving and Maximum Air Pressures	12
Maintenance Guidelines	12
Troubleshooting Guide	12
Frequently Asked Questions	13
Tuning the Air Pressure	13
Checking for Leaks	13
Fixing Leaks	13
Replacement Information	14
Contact Information	14

Introduction

The purpose of this publication is to assist with the installation, maintenance and troubleshooting of this Performance Universal Sleeve Over Strut kit.

It is important to read and understand the entire installation guide before beginning installation or performing any maintenance, service or repair. The information includes a hardware list, tool list, step-by-step installation information, maintenance tips, safety information and a troubleshooting guide.

Air Lift Company reserves the right to make changes and improvements to its products and publications at any time. For the latest version of this manual, contact Air Lift Company at (800) 248-0892 or visit our website at www.airliftcompany.com.

NOTATION EXPLANATION

Hazard notations appear in various locations in this publication. Information which is highlighted by one of these notations must be observed to help minimize risk of personal injury or possible improper installation which may render the vehicle unsafe. Notes are used to help emphasize areas of procedural importance and provide helpful suggestions. The following definitions explain the use of these notations as they appear throughout this guide.



INDICATES IMMEDIATE HAZARDS WHICH WILL RESULT IN SEVERE PERSONAL INJURY OR DEATH.



INDICATES HAZARDS OR UNSAFE PRACTICES WHICH COULD RESULT IN SEVERE PERSONAL INJURY OR DEATH.



INDICATES HAZARDS OR UNSAFE PRACTICES WHICH COULD RESULT IN DAMAGE TO THE MACHINE OR MINOR PERSONAL INJURY.

NOTE

Indicates a procedure, practice or hint which is important to highlight.

IMPORTANT SAFETY NOTICES

The installation of this kit does not alter the Gross Vehicle Weight Rating (GVWR) or payload of the vehicle. Check your vehicle's owner's manual and do not exceed the maximum load listed for your vehicle.

Gross Vehicle Weight Rating: The maximum allowable weight of the fully loaded vehicle (including passengers and cargo). This number — along with other weight limits, as well as tire, rim size and inflation pressure data — is shown on the vehicle's Safety Compliance Certification Label.

Payload: The combined, maximum allowable weight of cargo and passengers that the vehicle is designed to carry. Payload is GVWR minus the Base Curb Weight.



DO NOT INFLATE AIR SPRINGS WHILE OFF OF THE VEHICLE. DAMAGE TO ASSEMBLY MAY RESULT AND VOID WARRANTY.

Installation Diagram

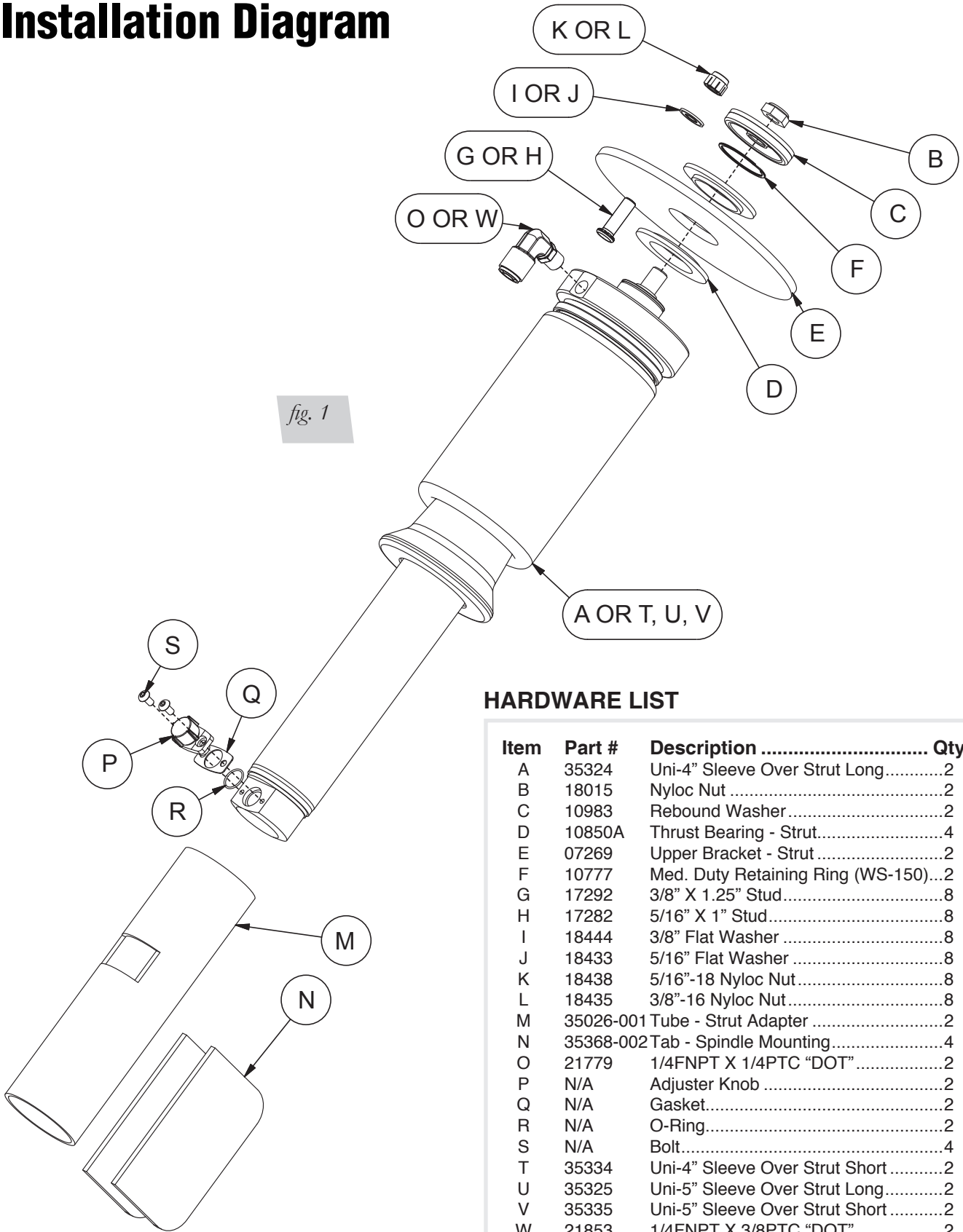

HARDWARE LIST

Item	Part #	Description	Qty
A	35324	Uni-4" Sleeve Over Strut Long	2
B	18015	Nyloc Nut	2
C	10983	Rebound Washer	2
D	10850A	Thrust Bearing - Strut	4
E	07269	Upper Bracket - Strut	2
F	10777	Med. Duty Retaining Ring (WS-150)	2
G	17292	3/8" X 1.25" Stud	8
H	17282	5/16" X 1" Stud	8
I	18444	3/8" Flat Washer	8
J	18433	5/16" Flat Washer	8
K	18438	5/16"-18 Nyloc Nut	8
L	18435	3/8"-16 Nyloc Nut	8
M	35026-001	Tube - Strut Adapter	2
N	35368-002	Tab - Spindle Mounting	4
O	21779	1/4FNPT X 1/4PTC "DOT"	2
P	N/A	Adjuster Knob	2
Q	N/A	Gasket	2
R	N/A	O-Ring	2
S	N/A	Bolt	4
T	35334	Uni-4" Sleeve Over Strut Short	2
U	35325	Uni-5" Sleeve Over Strut Long	2
V	35335	Uni-5" Sleeve Over Strut Short	2
W	21853	1/4FNPT X 3/8PTC "DOT"	2



Missing or damaged parts? Call Air Lift customer service at (800) 248-0892 for a replacement part.

Installing the Universal Sleeve Over Strut Kit

PREPARING THE VEHICLE

1. Elevate the vehicle and support the body with a hoist or jack stands.
2. Remove the wheels.

STRUT REMOVAL

1. Support the lower control arm, brake, and axle/spindle assembly.
2. Detach brake hoses, wheel speed sensors, and stabilizer link from the strut assembly (fig. 2).

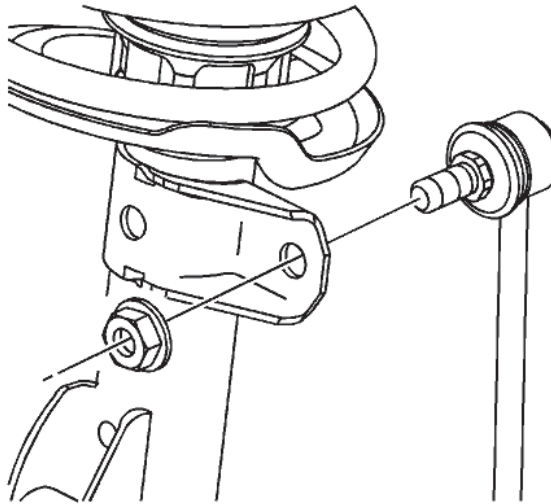

fig. 2

3. Remove the lower nuts and bolts from the lower spindle clevis (fig. 3).

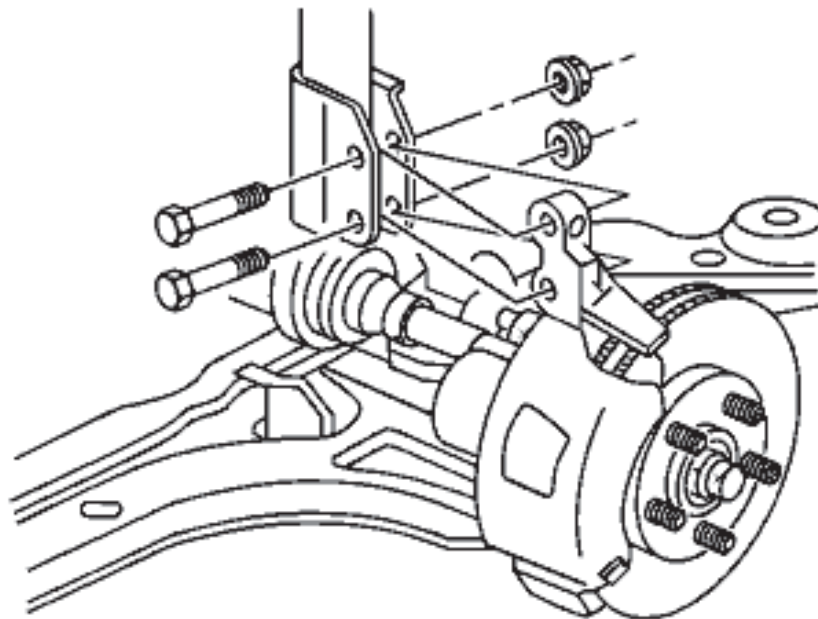
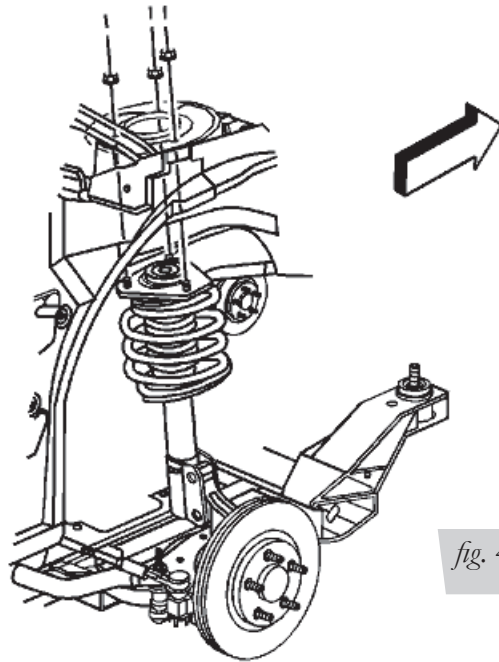

fig. 3

4. Lower the control arm, brake and axle/spindle assembly taking care to not pull against brake hoses or sensor wires.

- Remove the upper strut mounting bolts from vehicle body. Remove strut from the vehicle (fig. 4).



- Using a spring compressor, (**caution and attention to safety is required, spring will be under tension**) securely mount the spring in the compressor and remove the nut from the top of the strut rod. Slowly release the compressor with attention to safety. Once the spring and strut are free from tension, remove the stock upper mount. Pay attention to the order in which parts remove from the strut.

DETERMINING MOUNTING HEIGHT

- To determine the correct height of the new sleeve-over-strut assembly, reassemble the previously removed strut without the coil spring. Reinstall the strut into its mounting location and fasten in place with the nuts and bolts. Reattach the brake hoses, sensor wires and stabilizer links.
- Reinstall the wheels.
- While looking for possible interference, slowly lower the vehicle down until the suspension rests on the bump stops. Determine if this height provides adequate clearance for things such as brake lines, ABS wires, axle, control arms, stabilizer bar/link, tire/wheel clearances, camber, as well as bushing rotation, and ball joint articulation. Make height adjustments as necessary to your application.
- Measure the desired drop height at the mounting points (top spindle bolt center and top of upper mounting bracket). Depending on the kit (75563, 75567 long stroke or 75564, 75568 short stroke) add 5.9" (150mm) or 4.4" (112mm) to this height (5.9" or 4.4" is the stroke of the bellow-over-strut that will be measured later). Record this height for later use in **figure 9** on the corresponding kit drawing.
- Plan where the air-port and adjuster knob of the sleeve-over-strut would be best located at this point. Reference this to the orientation of the spindle tabs.
- Repeat STRUT REMOVAL steps.
- Using the stock upper mount as a bolt template, apply this pattern to the flat round bracket provided (E). Measure the bolt diameter needed. This kit provides either 5/16" or 3/8" press-in studs. These studs (G or H) are required because of "head clearance" to the air spring. **Other bolts may cause rubbing of the bracket to the air spring, causing**

noise and reducing product life. Depending on the bolt size, drill either 5/16" or 3/8" holes on the bolt pattern. Using a press; support closely around the hole to prevent deflecting of the bracket surface during the press operation. To install the studs, press against the stud head until the "teeth" are flush with the bracket. Refer to image below in figure 5.

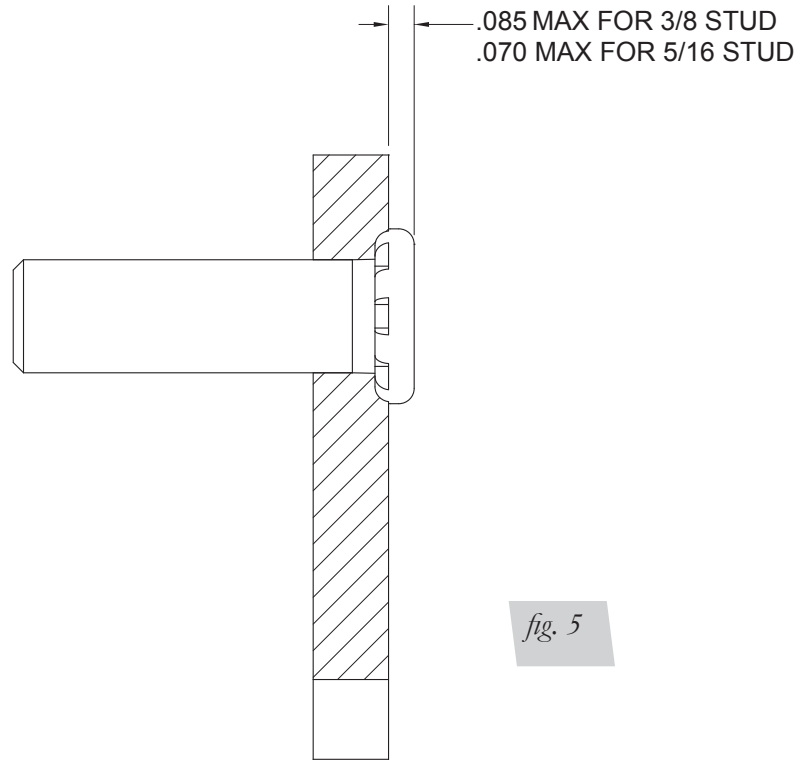

- Assemble this bracket to the strut by removing the nyloc (B) nut and rebound washer (C) then install the thrust bearings (D) onto the mount as shown in figure below. Install the snap ring (F) into the groove. Reinstall the rebound washer (C), rubber side down and nyloc nut (B).

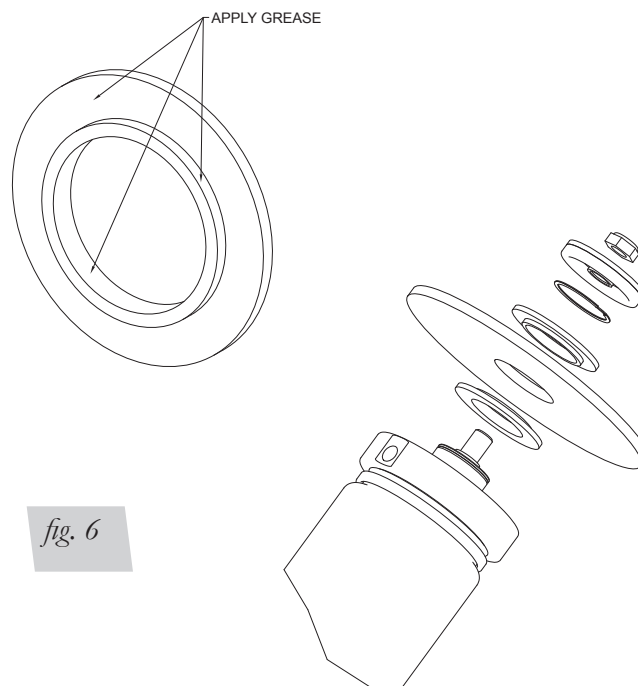

9. Replicate the hole pattern of the spindle mount to the supplied spindle tabs (N) by paying attention to hole diameter and hole center distance. If camber adjustment was necessary in Step 3 of DETERMINING MOUNTED HEIGHT, plan this within the design of the spindle tabs. The width between the spindle tabs needs to be measured on the factory strut.
10. Depending on the recorded mounted height taken in step 4 of DETERMINING MOUNTING HEIGHT, loosely assembly the adapter tube (M) and spindle tabs (N) to the strut for mock-up. Measure the distance (with the strut at max extension) from the top of the upper bracket to the spindle mounting holes. This should help you determine the correct length the adapter tube needs to be. Cut the adapter tube if necessary. Make sure the adjuster knob window gives adequate access to the adjuster. Modify the window if necessary.
11. Strut adapter tube (M) may need to be cut down to accept the spindle tab design and support the strut. The strut body needs to be within the tube by at least 2.25" as shown in Figure 7.

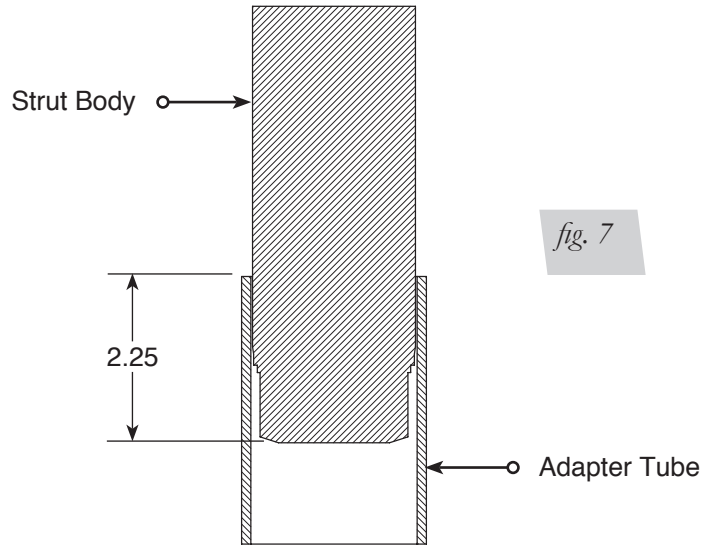

12. Tack weld the modified spindle tabs (N) to the adapter tube (M), then tack weld the adapter tube to the strut. Quench welds in water.
13. Create any other tabs that may be necessary including but not limited to, stabilizer tabs, brake line tabs, sensor wire tabs, etc.
14. Lightly grease the strut body with non-petroleum based grease above the snap ring groove. Clip the air spring over the snap ring, forcing the snap ring into the strut body groove as shown in Figure 8.

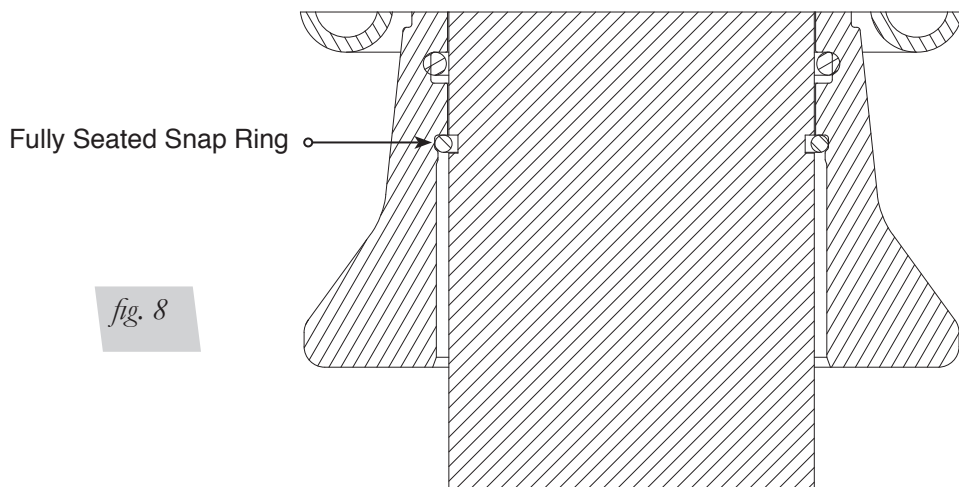

15. Insert the assembly into the vehicles mounting points and trial fit. Verify that your design is correct before finish welding. Check for air spring clearance by measuring at the spring's maximum diameter. Any rub or contact will cause premature wear of the assembly. If applicable, check stabilizer tab location, brake line location etc. Remove the strut assembly from vehicle when the design is verified.
16. When welding the adapter tube to the strut body, **DO NOT** weld continuously around the strut body! This action will overheat the internals of the strut and potentially render the strut ineffective. Weld the adapter tube to the strut in three equally spaced .75" sections and quench in water immediately after. Fully weld the spindle tabs and immediately quench in water after each tab.
17. Either cover and protect the air spring assembly or remove it from the strut for welding/painting. The air spring can be removed by unthreading the nyloc nut at the top of the strut and removing the rebound washer. Lightly tap on the lower end cap with a rubber mallet. This will release the snap ring from the strut body, allowing the air spring to be removed.

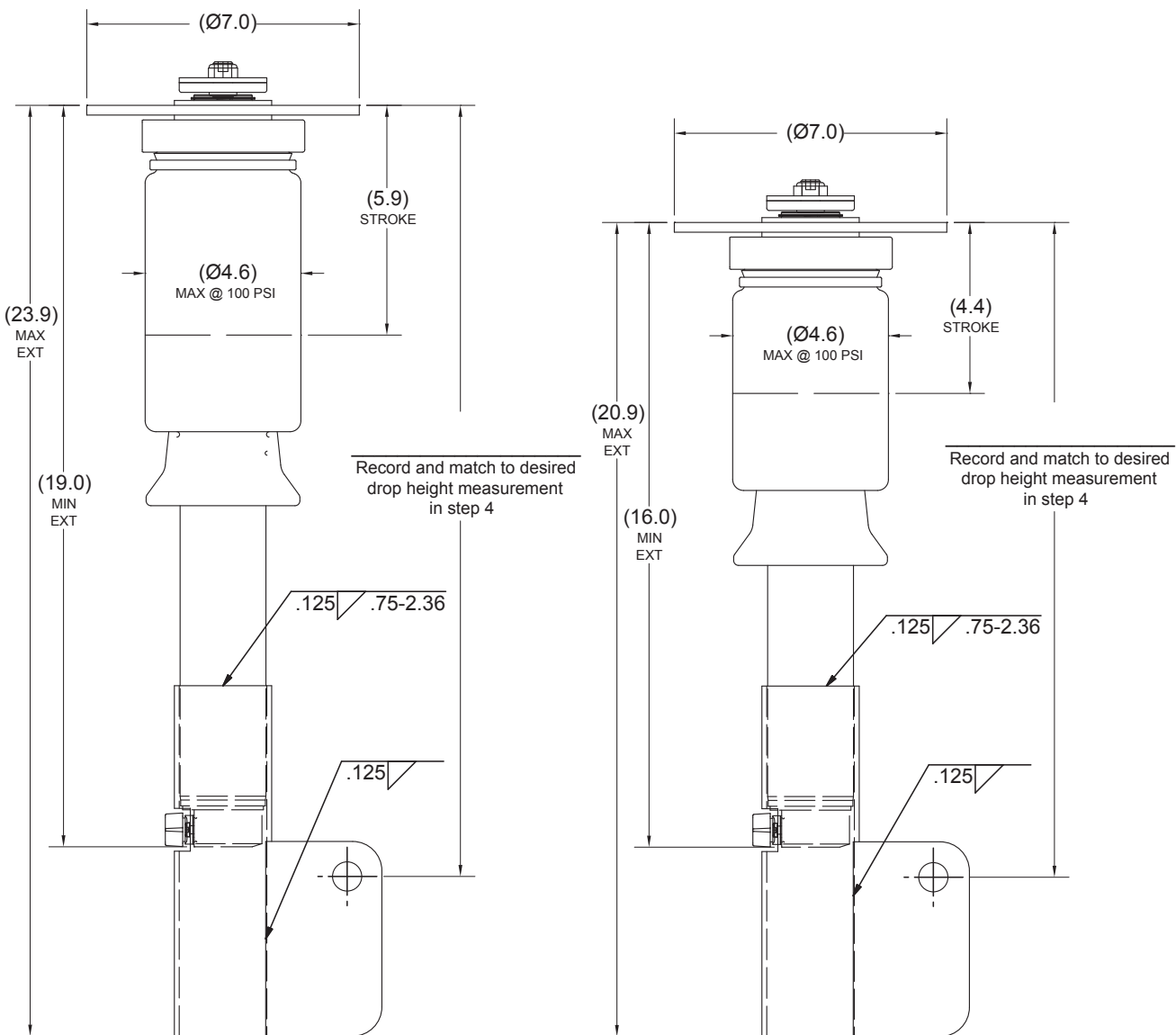

Kit 75563 Shown
Kit 75567 Max Diameter
Measures 5.6"

fig. 9

Kit 75564 Shown
Kit 75564 Max Diameter
Measurs 5.6"

PAINTING

1. Remove the nyloc nut (B), rebound washer (C), thrust bearings (D), retaining ring (F) and upper bracket (E). Mask the threads of the upper bracket. Cover the air spring and adjuster valve to prevent paint from applying to these surfaces.
2. Remove any sharp edges or weld splatter from the strut assembly.
3. Wipe strut assembly and upper bracket assembly down with clean, oil-free rags to remove any possible contaminants.
4. Paint the strut and upper bracket. Do not get paint on the threads of the bracket or inside the adjuster valve. Allow adequate drying time before handling.

SLEEVE-OVER-STRUT INSTALL

1. Install the adjuster knob (P) by applying the gasket (Q) on the mating surface of the knob, and then apply the o-ring (R) around the adjuster plunger. Align the holes of the knob to the threads and bolt down with the two bolts (S).
2. Install fitting (O) into the upper end-cap of the air spring with thread sealant or Teflon tape applied to the threads of the fitting. Tighten finger tight and torque fitting 1-3/4 turns beyond hand tight.

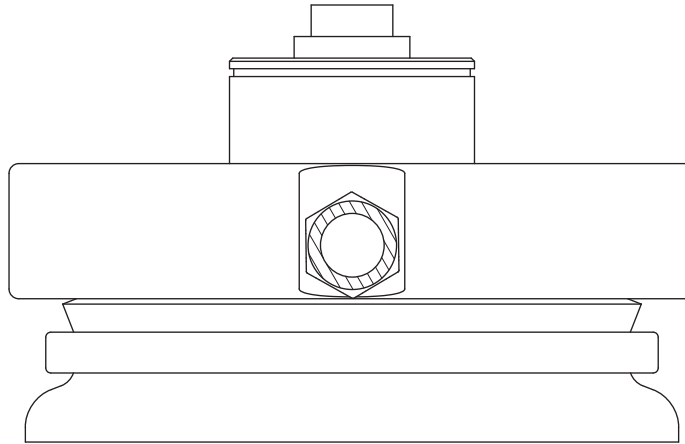

fig. 10

3. Apply a thin layer of grease to the mating surfaces of the thrust bearings (D). Attach the upper bracket to the air spring as shown in fig 6.
4. Reinstall the air spring if previously removed.
5. Install into the vehicle using the supplied washers (I or J) and nuts (K or L). The 5/16" nuts are to be torque to 22 Nm (16 ft/lbs). The 3/8" nuts are to be torque to 37 Nm (27 ft/lbs).
6. Reinstall the lower spindle clevis using the factory removed bolts. Torque to manufacturers specification.

Before Operating

1. Some struts for this vehicle come with a nine-position damping dial for added adjustability (fig. 11). If not, proceed to 2.

Before driving your vehicle, set the new struts to their highest setting by turning the black dial on the shaft of the strut as far as it will go to the right (position 9).

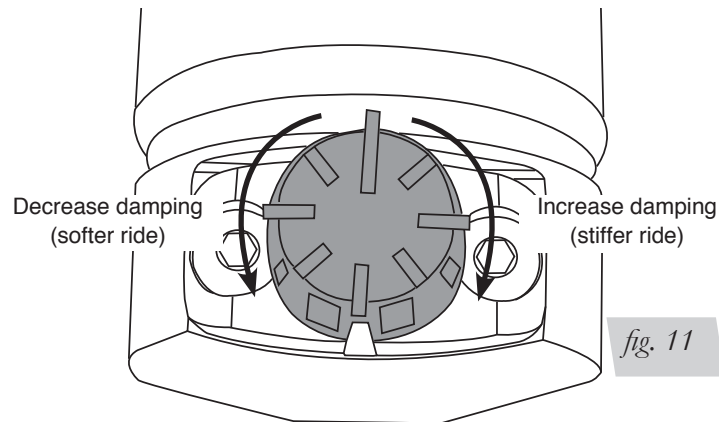

2. Next, completely deflate and reinflate the air bags 2-3 times. This procedure will purge any trapped air in the dampers and allow for maximum performance. For ride performance and the most versatility, Lifestyle recommends setting the strut dial (if equipped) to at least position 6 or higher.

CAUTION

MAKE SURE THE FRONT WHEELS ARE STRAIGHT WHEN DEFLATING AND REINFLATING AIR BAGS.

3. Inflate and deflate the system (do not exceed 125 PSI) to check for clearance or binding issues. With the air springs deflated, check clearances on everything so as not to pinch brake lines, vent tubes, etc. Clear lines if necessary.
4. Inflate the air springs to 75PSI - 90PSI and check all connections for leaks.
5. Air Lift part #27669 or #27671, AutoPilot V2 Air Management System, is highly recommended for this product.
6. Please continue by reading the Product Use, Maintenance and Servicing section.

INSTALLATION CHECKLIST

- Clearance test — Inflate the air springs to 75-90 PSI and make sure there is at least ½” clearance from anything that might rub against each sleeve. Be sure to check the tire, brake drum, frame, shock absorbers and brake cables.

- Leak test before road test — Inflate the air springs to 75PSI - 90PSI and check all connections for leaks. All leaks must be eliminated before the vehicle is road tested.

- Heat test — Be sure there is sufficient clearance from heat sources, at least 6” for air springs and air lines. If a heat shield was included in the kit, install it. If there is no heat shield, but one is required, call Air Lift customer service at (800) 248-0892.

- Fastener test — Recheck all bolts for proper torque.

- Road test — The vehicle should be road tested after the preceding tests. Inflate the springs to recommended driving pressures. Drive the vehicle 10 miles and recheck for clearance, loose fasteners and air leaks.

- Operating instructions — If professionally installed, the installer should review the operating instructions with the owner. Be sure to provide the owner with all of the paperwork that came with the kit.

Technician’s Signature _____

Date _____

POST-INSTALLATION CHECKLIST

- Overnight leak down test — Recheck air pressure after the vehicle has been used for 24 hours. If the pressure has dropped more than 5 PSI, then there is a leak that must be fixed. Either fix the leak yourself or return to the installer for service.

- Air pressure requirements — I understand the air pressure requirements of my air spring system. Regardless of load, the air pressure should always be adjusted to maintain adequate ride height at all times while driving.

- Thirty day or 500 mile test — I understand that I must recheck the air spring system after 30 days or 500 miles, whichever comes first. If any part shows signs of rubbing or abrasion, the source should be identified and moved, if possible. If it is not possible to relocate the cause of the abrasion, the air spring may need to be remounted. If professionally installed, the installer should be consulted. Check all fasteners for tightness.

Product Use, Maintenance and Servicing

Suggested Driving Air Pressure	Maximum Air Pressure
45 - 75 PSI	125 PSI
FAILURE TO MAINTAIN ADEQUATE MINIMUM PRESSURE (OR PRESSURE PROPORTIONAL TO LOAD) WILL RESULT IN BOTTOMING OUT, OVER-EXTENSION OR RUBBING AGAINST ANOTHER COMPONENT AND WILL VOID THE WARRANTY.	

MAINTENANCE GUIDELINES

NOTE

By following these steps, vehicle owners will obtain the longest life and best results from their air spring.

1. Check the air pressure before driving.
2. Never inflate beyond 125 PSI.
3. If you develop an air leak in the system, use a soapy water solution to check all air line connections, before deflating and removing the spring.
4. When increasing load, always adjust the air pressure to maintain normal ride height. Increase or decrease pressure from the system as necessary to attain normal ride height for optimal ride and handling. Remember that loads carried behind the axle (including tongue loads) require more leveling force (pressure) than those carried directly over the axle.

CAUTION

FOR YOUR SAFETY AND TO PREVENT DAMAGE TO YOUR VEHICLE, DO NOT EXCEED MAXIMUM GROSS VEHICLE WEIGHT RATING (GVWR), AS INDICATED BY THE VEHICLE MANUFACTURER. ALTHOUGH YOUR AIR SPRINGS ARE RATED AT A MAXIMUM INFLATION PRESSURE OF 125 PSI, THE AIR PRESSURE ACTUALLY NEEDED IS DEPENDENT ON YOUR LOAD.

5. Always add air to the springs in small quantities, checking the pressure frequently. Sleeves require less air volume than a tire and inflate quickly.
6. Should it become necessary to raise the vehicle by the frame, make sure the control system is turned off before lifting.

Troubleshooting Guide

1. Leak test the air line connections, the threaded connection into the air spring, and all fittings in the control system.
2. Inspect the air lines to be sure none are pinched. Tie straps may be too tight. Loosen or replace the strap and replace leaking components.
3. Inspect the air line for holes and cracks. Replace as needed.
4. Look for a kink or fold in the air line. Reroute as needed.

If the preceding steps do not solve the problem, it is possibly caused by a failed air spring — either a factory defect or an operating problem. Please call Air Lift at (800) 248-0892 for assistance.

Frequently Asked Questions

Q. Will installing air springs increase the weight ratings of a vehicle?

No. Adding air springs will not change the weight ratings (GAWR, GCWR and/or GVWR) of a vehicle. Exceeding the GVWR is dangerous and voids the Air Lift warranty.

Q. How long should air springs last?

If the air springs are properly installed and maintained they can last indefinitely.

Q. Will raising the vehicle on a hoist for service work damage the air springs?

No. The vehicle can be lifted on a hoist for short-term service work such as tire rotation or oil changes. However, if the vehicle will be on the hoist for a prolonged period of time, support the axle with jack stands in order to take the tension off of the air springs.

Tuning the Air Pressure

Pressure determination comes down to three things — level vehicle, ride comfort, and stability.

1. Level vehicle

If the vehicle's headlights are shining into the trees or the vehicle is leaning to one side, then it is not level. Raise the air pressure to correct either of these problems and level the vehicle.

2. Ride comfort

If the vehicle has a rough or harsh ride it may be due to either too much pressure or not enough. Try different pressures to determine the best ride comfort. See Air Lift suggested driving air pressure.

3. Stability

Stability translates into safety and should be the priority, meaning the driver may need to sacrifice a perfectly level and comfortable ride. Stability issues include roll control, bounce, dive during braking and sponginess. Tuning out these problems usually requires additional air pressure, strut damping, or both.

Checking for leaks

1. Inflate the air spring to 80 PSI.
2. Spray all connections and the inflation valves with a solution of 1/5 liquid dish soap and 4/5 water. Spot leaks easily by looking for bubbles in the soapy water.
3. After the test, deflate the springs to the minimum pressure required to restore the system to normal ride height.
4. Check the air pressure again after 24 hours. A 2 - 4 PSI loss after initial installation is normal. Retest for leaks if the loss is more than 5 lbs.

Fixing Leaks

1. If there is a problem with a swivel fitting:
 - a. Check the air line connection by deflating the spring and removing the line by pulling the collar against the fitting and pulling firmly on the air line. Trim 1" off the end of the air line. Be sure the cut is clean and square (see fig. 12). Reinsert the air line into the push-to-connect fitting.

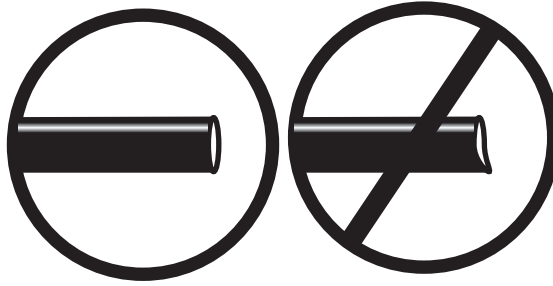

fig. 12

- b. Check the threaded connection by tightening the swivel fitting another $\frac{1}{2}$ turn. If it still leaks, deflate the air spring, remove the fitting, and re-coat the threads with thread sealant. Reinstall by hand tightening as much as possible and then use a wrench for an additional two turns.
2. If the preceding steps have not resolved the problem, call Air Lift customer service at (800) 248-0892.

Replacement Information

If you need replacement parts, contact the local dealer or call Air Lift customer service at (800) 248-0892. Most parts are immediately available and can be shipped the same day.

Contact Air Lift Company customer service at (800) 248-0892 first if:

- Parts are missing from the kit.
- Need technical assistance on installation or operation.
- Broken or defective parts in the kit.
- Wrong parts in the kit.
- Have a warranty claim or question.

Contact the retailer where the kit was purchased:

- If it is necessary to return or exchange the kit for any reason.
- If there is a problem with shipping if shipped from the retailer.
- If there is a problem with the price.

Contact Information

If you have any questions, comments or need technical assistance contact our customer service department by calling (800) 248-0892. For calls from outside the USA or Canada, our local number is (517) 322-2144. You may also contact customer service anytime by e-mail at techsupport@airliftperformance.com.

For inquiries by mail, our address is PO Box 80167, Lansing, MI 48908-0167. Our shipping address for returns is 2727 Snow Road, Lansing, MI 48917.

You may also contact our sales team anytime by e-mail at sales@airliftperformance.com or on the web at www.airliftperformance.com.

NOTES

NOTES

Need Help?

Contact our customer service department by calling (800) 248-0892. For calls from outside the USA or Canada, our local number is (517) 322-2144.



Thank you for purchasing Air Lift Performance products!

Air Lift Performance • 2727 Snow Road • Lansing, MI 48917 or PO Box 80167 • Lansing, MI 48908-0167
Toll Free (800) 248-0892 • Local (517) 322-2144 • Fax (517) 322-0240 • www.airliftperformance.com

Printed in
the USA