

# AirCELL

by AIR LIFT®

## Kit 52205

### *Dodge 1500*

### *Pickup 2 & 4WD*

rear application



## INSTALLATION GUIDE

For maximum effectiveness and safety, please read these instructions completely before proceeding with installation.

*Failure to read these instructions can result in an incorrect installation.*





# TABLE OF CONTENTS



<b>Introduction</b> .....	<b>2</b>
Important Safety Notice .....	2
Notation Explanation .....	2
<b>Installation Diagram</b> .....	<b>3</b>
Hardware List .....	3
Tools List .....	3
<b>Installing the AirCell System</b> .....	<b>4</b>
Assembling and Attaching the System .....	4
<b>Warranty and Return Policy</b> .....	<b>6</b>
<b>Replacement Information (back of manual)</b>	
<b>Contact Information (back of manual)</b>	

# Introduction

The purpose of this publication is to assist with the installation of the AirCell load support kit. AirCell utilizes rugged, long-lasting closed cell urethane foam which traps air to provide a cushion against sag. AirCell is designed especially for vehicles that maintain constant loads such as work trucks, fleet and delivery vehicles and are easy to install with no air lines or fittings.

It is important to read and understand the entire installation guide before beginning installation. The information here includes a hardware list, tool list and step-by-step installation information.

Air Lift Company reserves the right to make changes and improvements to its products and publications at any time. For the latest version of this manual, contact Air Lift Company at (800) 248-0892 or visit our website at [www.airliftcompany.com](http://www.airliftcompany.com).

## IMPORTANT SAFETY NOTICE

The installation of this kit does not alter the Gross Vehicle Weight Rating (GVWR) or payload of the vehicle. Check your vehicle's owner's manual and do not exceed the maximum load listed for your vehicle.

**Gross Vehicle Weight Rating:** The maximum allowable weight of the fully loaded vehicle (including passengers and cargo). This number — along with other weight limits, as well as tire, rim size and inflation pressure data — is shown on the vehicle's Safety Compliance Certification Label.

**Payload:** The combined, maximum allowable weight of cargo and passengers that the truck is designed to carry. Payload is GVWR minus the Base Curb Weight.

## NOTATION EXPLANATION

Hazard notations appear in various locations in this publication. Information which is highlighted by one of these notations must be observed to help minimize risk of personal injury or possible improper installation which may render the vehicle unsafe. Notes are used to help emphasize areas of procedural importance and provide helpful suggestions. The following definitions explain the use of these notations as they appear throughout this guide.

- |                |   |
|----------------|---|
| <b>DANGER</b>  | INDICATES IMMEDIATE HAZARDS WHICH WILL RESULT IN SEVERE PERSONAL INJURY OR DEATH.                           |
| <b>WARNING</b> | INDICATES HAZARDS OR UNSAFE PRACTICES WHICH COULD RESULT IN SEVERE PERSONAL INJURY OR DEATH.                |
| <b>CAUTION</b> | INDICATES HAZARDS OR UNSAFE PRACTICES WHICH COULD RESULT IN DAMAGE TO THE MACHINE OR MINOR PERSONAL INJURY. |

---

**NOTE** *Indicates a procedure, practice or hint which is important to highlight.*

---

# Installation Diagram

### Important Safety Notice

The installation of this kit does not alter the Gross Vehicle Weight Rating (GVWR) or payload of the vehicle. Check your vehicle's owner's manual and do not exceed the maximum load listed for your vehicle.

**Gross Vehicle Weight Rating:** The maximum allowable weight of the fully loaded vehicle (including passengers and cargo). This number — along with other weight limits, as well as tire, rim size and inflation pressure data — is shown on the vehicle's Safety Compliance Certification Label.

**Payload:** The combined, maximum allowable weight of cargo and passengers that the truck is designed to carry. Payload is GVWR minus the Base Curb Weight.

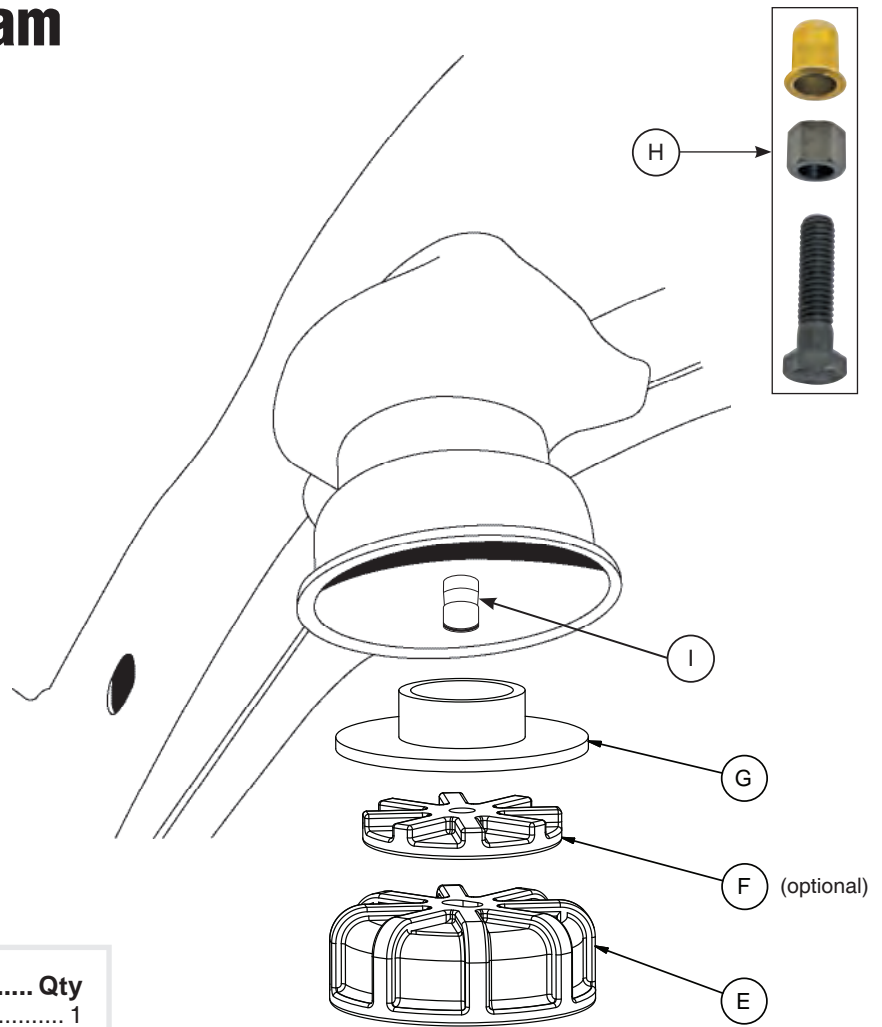

fig. 1

## TOOLS LIST

Description.....	Qty
Hoist or floor jacks.....	1
Safety stands.....	2
Metric and standard sockets.....	1
Metric and standard wrenches.....	1
Ratchet.....	1
Drill or Hand Grinder.....	1
9/16" Drill Bit.....	1

## HARDWARE LIST

Item	Part #	Description.....	Qty
A	52023	Spring.....	2
B	17442	3/8"-16 x 3 Bolt.....	2
C	18427	3/8" Lock Washer.....	2
D	18444	3/8" Flat Washer.....	2
E	10911	Spring Cup.....	2
F	13244	Cup Spacer (optional).....	2
G	03710	Upper Bracket.....	2
H	10936	Nutsert Tool w/ Nutsert.....	1
I	18585	Nutsert.....	1

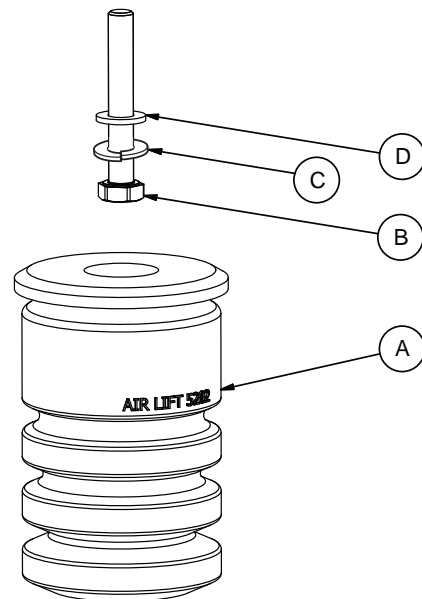

Missing or damaged parts? Call Air Lift customer service at (800) 248-0892 for a replacement part.

# Installing the AirCell System

## ASSEMBLING AND ATTACHING THE SYSTEM

1. Jack up the rear of the vehicle or raise on a hoist. Support the frame with safety stands. Lower the axle of the vehicle until the suspension is fully extended.
2. Remove the existing jounce bumpers on both sides (they just pull out from the mounting cup).

It will be necessary to install a nutsert (I) into the hole at the bottom of the jounce bumper mounting cup (fig. 2). Use the nutsert tool (H) provided to install the nutsert (I) as follows:

3. It will be necessary to open the hole up by using a drill with a 9/16" drill bit. Or you can open the hole up slightly using a hand grinder (be sure to keep the hole as round as you can if you use the grinder). It is preferred that the hole be a tight fit for the nutsert (I).
4. With a nutsert (I) on the nutsert tool (H), insert the nutsert (I) into the hole. While holding the body of the nutsert tool (H) with a wrench, turn the head of the bolt clockwise until the nut cannot be turned anymore (make sure it is tight) - (fig. 3). Remove the nutsert tool (H) by turning the bolt counter clockwise.

### NOTE

*It may be hard to turn the bolt at first when starting to install! Once the bolt breaks loose and starts to tighten, it will be easier as you tighten it while still holding the body of the nutsert tool (H).*



- 
5. Attach the upper bracket (G)/spring cup (E) to the stock jounce bumper cup (with the new nutsert [I] installed) using a 3/8-16X3" bolt (B), 3/8 lock washer (C) and 3/8 flat washer (D). (fig. 1)

**NOTE**

*The spring cup (E) has a slot in it, position the cup so the cup offsets to the rear of the vehicle. Tighten securely (fig. 1).*

- 
6. Insert the spring (A) into the spring cup (E). A twisting motion while pushing the spring (A) into the spring cup (E) will make the installation quicker. Make sure the spring (A) snaps into position into the spring cup (E).

**NOTE**

*Applying grease or soap around the engagement flange of the spring (A) will help in aiding the spring (A) "snap" into the spring cup (E).*

**OPTIONAL**

*You can adjust the loaded height of the vehicle by adding the optional cup spacer (F) between the spring cup (E) and the upper bracket (G) (fig. 1).*

---

# Warranty and Returns Policy

Air Lift Company warrants its products, for the time periods listed below, to the original retail purchaser against manufacturing defects when used on catalog-listed applications on cars, vans, light trucks and motorhomes under normal operating conditions for as long as Air Lift manufactures the product. The warranty does not apply to products that have been improperly applied, improperly installed, used in racing or off-road applications, used for commercial purposes, or which have not been maintained in accordance with installation instructions furnished with all products. The consumer will be responsible for removing (labor charges) the defective product from the vehicle and returning it, transportation costs prepaid, to the dealer from which it was purchased or to Air Lift Company for verification.

Air Lift will repair or replace, at its option, defective products or components. A minimum \$10.00 shipping and handling charge will apply to all warranty claims. Before returning any defective product, you must call Air Lift at (800) 248-0892 in the U.S. and Canada (elsewhere, (517) 322-2144) for a Returned Materials Authorization (RMA) number. Returns to Air Lift can be sent to: Air Lift Company • 2727 Snow Road • Lansing, MI • 48917.

Product failures resulting from abnormal use or misuse are excluded from this warranty. The loss of use of the product, loss of time, inconvenience, commercial loss or consequential damages is not covered. The consumer is responsible for installation/reinstallation (labor charges) of the product. Air Lift Company reserves the right to change the design of any product without assuming any obligation to modify any product previously manufactured.

This warranty gives you specific legal rights and you may also have other rights that vary from state-to-state. Some states do not allow limitations on how long an implied warranty lasts or allow the exclusion or limitation of incidental or consequential damages. The above limitation or exclusion may not apply to you. There are no warranties, expressed or implied including any implied warranties of merchantability and fitness, which extend beyond this warranty period. There are no warranties that extend beyond the description on the face hereof. Seller disclaims the implied warranty of merchantability. (Dated proof of purchase required.)

<b>AirCell</b> .....	<b>Lifetime Limited</b>	<b>Load Controller (I)</b> .....	<b>2 Year Limited</b>
<b>Air Lift 1000</b> .....	<b>Lifetime Limited</b>	<b>Load Controller (II)</b> .....	<b>2 Year Limited</b>
<b>RideControl</b> .....	<b>Lifetime Limited</b>	<b>SmartAir</b> .....	<b>2 Year Limited</b>
<b>SlamAir</b> .....	<b>Lifetime Limited</b>	<b>Wireless AIR</b> .....	<b>2 Year Limited</b>
<b>LoadLifter 5000*</b> .....	<b>Lifetime Limited</b>	<b>Other Accessories</b> .....	<b>2 Year Limited</b>
<b>LifeStyle Systems**</b> .....	<b>1 Year Limited</b>		

*\*formerly SuperDuty*

*\*\*formerly EasyStreet*









## Replacement Information

If you need replacement parts, contact the local dealer or call Air Lift customer service at (800) 248-0892. Most parts are immediately available and can be shipped the same day.

**Contact Air Lift Company customer service at (800) 248-0892, first if:**

- Parts are missing from the kit.
- Need technical assistance on installation or operation.
- Broken or defective parts in the kit.
- Wrong parts in the kit.
- Have a warranty claim or question.

**Contact the retailer where the kit was purchased:**

- If it is necessary to return or exchange the kit for any reason.
- If there is a problem with shipping if shipped from the retailer.
- If there is a problem with the price.

## Need Help?

Contact our customer service department by calling (800) 248-0892, Monday through Friday, 8 a.m. to 7 p.m. Eastern Time. For calls from outside the USA or Canada, our local number is (517) 322-2144.

**Register your warranty online at  
[www.airliftcompany.com/warranty](http://www.airliftcompany.com/warranty)**



*Thank you for purchasing Air Lift products — the professional installer's choice!*

Air Lift Company • 2727 Snow Road • Lansing, MI 48917 or PO Box 80167 • Lansing, MI 48908-0167  
Toll Free (800) 248-0892 • Local (517) 322-2144 • Fax (517) 322-0240 • [www.airliftcompany.com](http://www.airliftcompany.com)

Printed in  
the USA