

INSTALLATION GUIDE

AMP **Power Step** RESEARCH MADE IN USA

APPLICATION	MODEL YR	PART #
Hummer H3	2006 - up	75116-01A
Hummer H3T	2009 - up	75116-01A

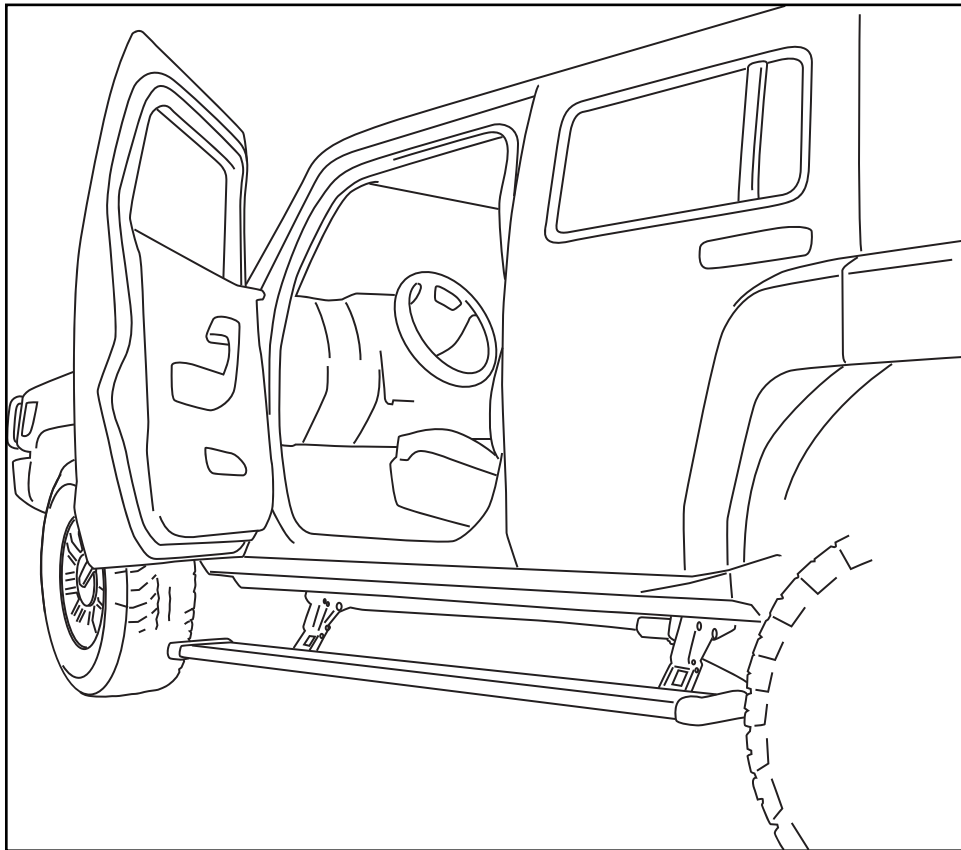

INSTALLATION TIME

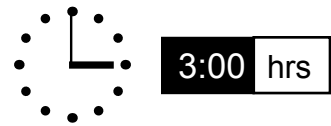

SKILL LEVEL



4= Experienced

TOOLS REQUIRED

- Safety goggles
- Measuring tape
- Flat blade screwdriver
- Right angle drill
- 9/32" drill bit
- 17 mm socket
- 15 mm socket
- 10 mm socket
- T 15 Torx driver
- Ratchet wrench and extension
- Pliers
- Wire crimpers
- Wire stripper / cutter
- 3/16" hex key wrench (allen wrench)
- 4mm hex key wrench (allen wrench)
- Electrical tape
- Weather proof caulking (silicone sealer)

AMP RESEARCH TECH SUPPORT 1-888-983-2204 (Press 2) Monday - Friday, 6:00 AM - 5:00 PM PST

Designed and manufactured by AMP Research®. Patent Number 6,830,257; 6,641,158; 6,834,875; 6,938,909; 6,942,233; 7,007,961; 7,055,839; 7,163,221; 7,367,574; 7,380,807; 7,398,985; 7,413,204; 7,487,986. Other US and Worldwide patents pending. Made in USA © 2010 AMP Research
5-year limited warranty. Professional installation is recommended.

Purpose: Due to vehicle-build variations the Power Step may not correctly align with vehicle cladding. Using supplied shims, please follow the instructions below to correct the alignment.

Misalignment:	Shim Correction:
The gap between board and vehicle cladding is too large toward rear of running board.	Shim rear mount at lower bolt. (diagram below)
The gap between board and vehicle cladding is too small toward rear of running board.	Shim rear mount at upper bolt. (diagram below)
The gap between board and vehicle cladding is too large toward front end of running board.	Shim front mount at lower bolt. (diagram below)
The gap between board and vehicle cladding is too small toward front end of running board.	Shim front mount at upper bolt. (diagram below)

Shim Placement: Place shim(s) **ONLY WHERE NEEDED** as indicated above in “Misalignment/ Shim Correction” chart.

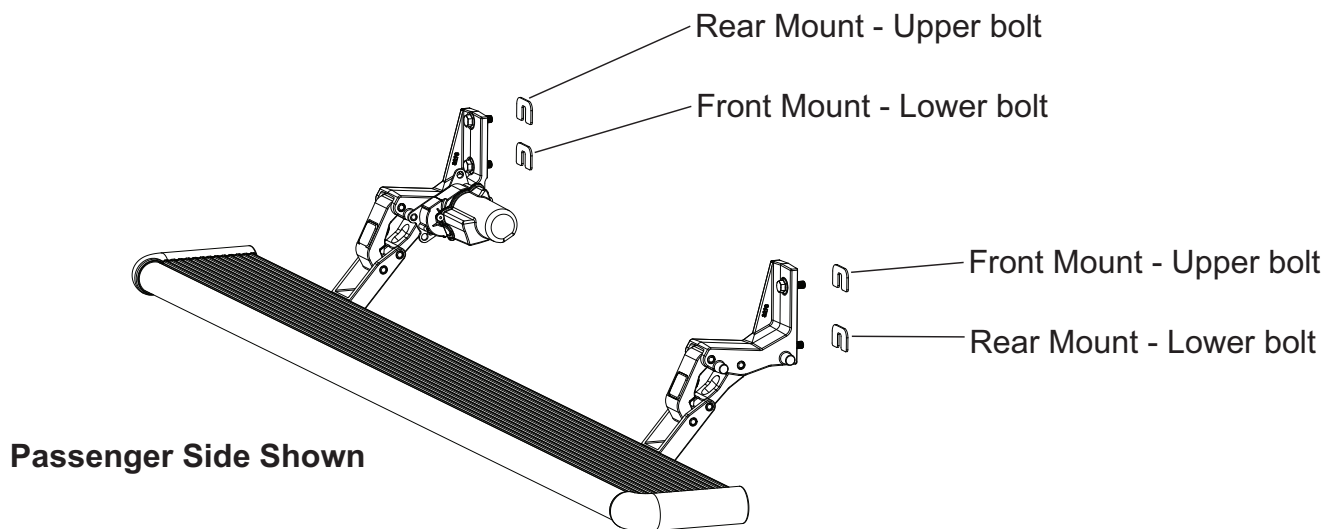

PARTS LIST AND HARDWARE IDENTIFICATION

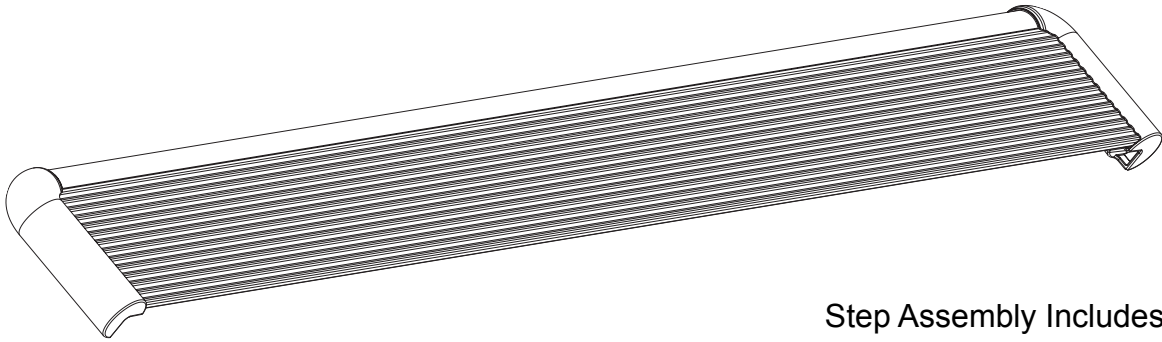

① x2
20-02874-90
Step Assembly

Step Assembly Includes:
19-02869-11 Endcap Left (x1)
19-02869-12 Endcap Right (x1)
19-02663-90 T-Nut Insert (x2)
19-02822-90 Rivet (x2)

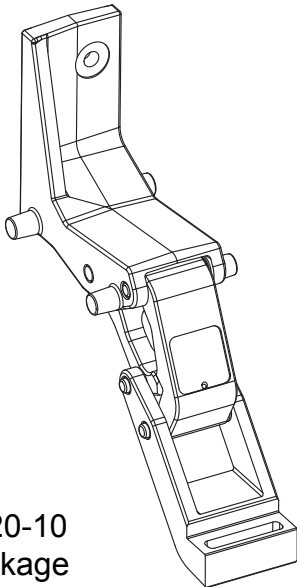

② x2
10-03220-10
Idler Linkage

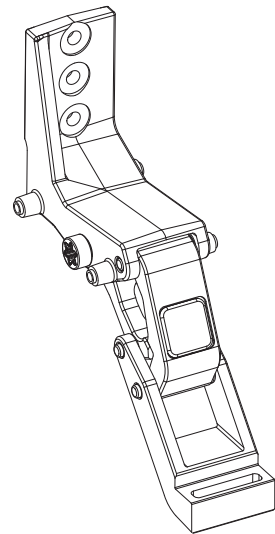

③
10-03219-10 Motor Linkage Driver Side (1)
10-03219-11 Motor Linkage Passenger Side (1)

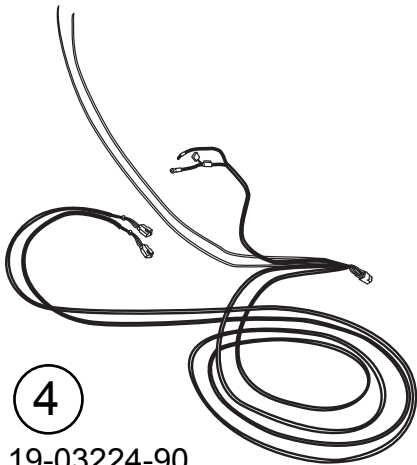

④
19-03224-90
Wire Harness

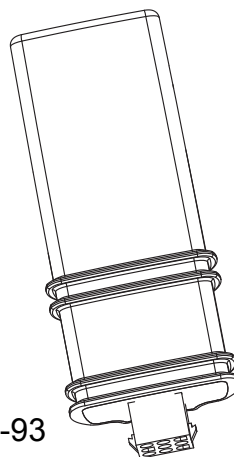

⑤
19-03297-93
Controller

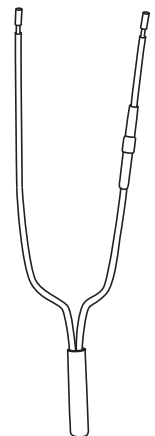

⑥ x4
19-02727-90
Single Diode

PARTS LIST AND
HARDWARE
IDENTIFICATION

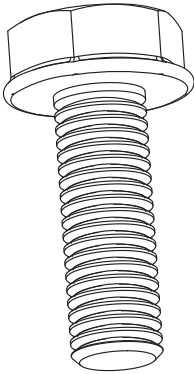

7 x8
19-03341-90
Hex Flange Bolt

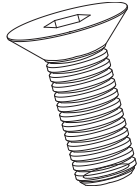

8 x4
19-03352-90
Flat Head Cap Screw

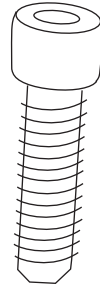

9 x8
19-02802-90
Socket Cap Screw

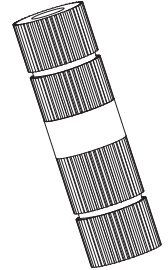

10
19-03354-90
Posi-Tap™ (Red/Grey)

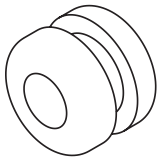

11
19-02640-90
Grommet



12 x6
19-02721-90
Cinch Fastener

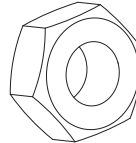

13 x2
19-03065-90
Hex Nut



14 Includes x4
19-03142-90
Shim



15 x25
19-02805-90
Cable Tie 7"

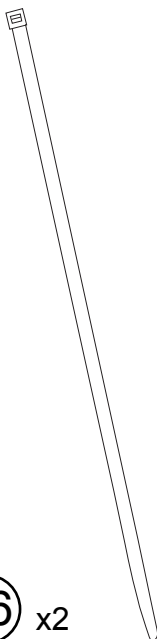

16 x2
19-03339-90
Cable Tie 11"

19-03290-90
Base Plate

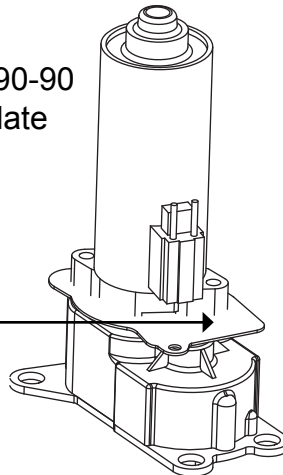

17 x2
19-03289-91
Motor

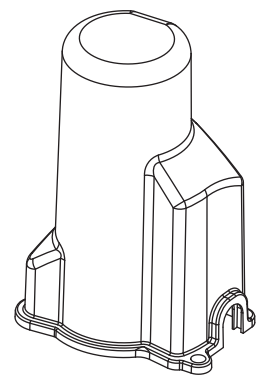

18 x2
19-03238-90
Motor Cover

Remove existing rock rails and steps from the vehicle.

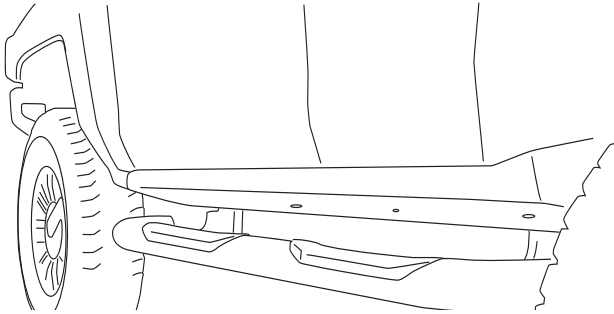

Step 2 for **H3T ONLY**

1

H3T ONLY

Skip steps 3 - 5

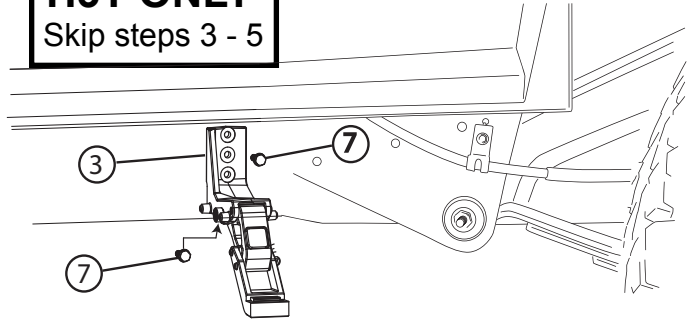

Mount motor linkage to frame on driver and passenger side with M10 flange bolts. Finger tighten bolts. Use middle hole on top and slotted hole on bottom. Drive shaft should face front. See close up below in step 4

2

Unbolt emergency brake cable bracket. Cable needs to be on the outside of linkage assembly.

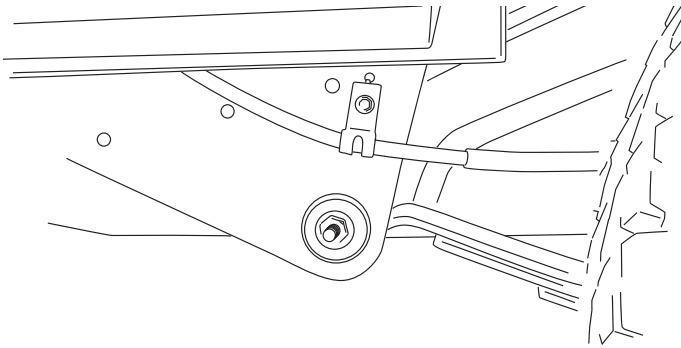

3

Mount drive and passenger motor linkage assembly to frame using supplied M10x30 flange bolts. Drive shaft should be facing front of vehicle. Finger tighten bolts.

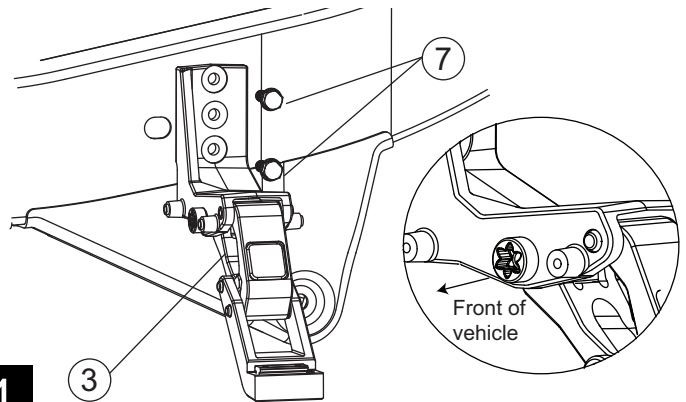

4

Bolt up emergency brake cable bracket. Torque bolts to 6ft-lbs(8N-m)

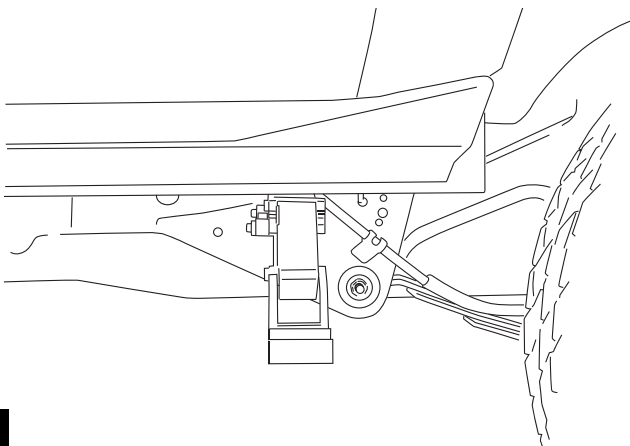

5

Mount idler linkage assemblies on driver and passenger side to forward frame locations with M10 flange bolts. Finger tighten bolts.

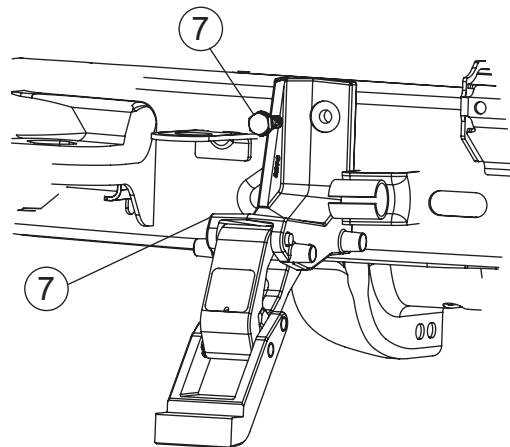

6

AMP RESEARCH POWER STEP – H3

To mount running boards, slide T-nuts into position (Align with mounting holes).

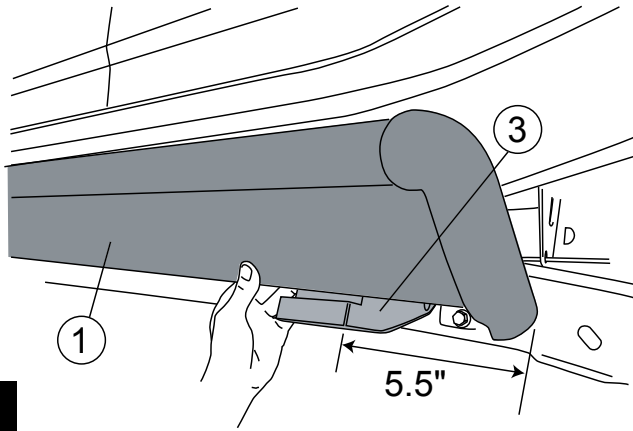

7

Tighten 4 bolts with 3/16" Allen wrench.
Torque bolts to 10ft-lbs. (13.5 Nm)

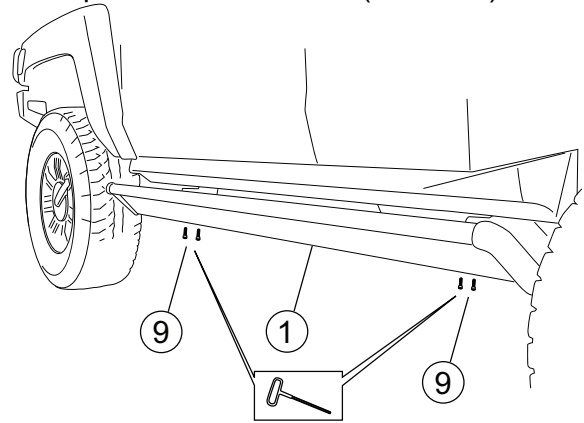

8

Torque linkage bolts to 40ft-lbs(54N-m)

Remove power fuse. Using supplied M6 nuts, attach power lead (RED) wire to positive terminal on battery. Attach ground lead (BLACK) to negative terminal on battery.

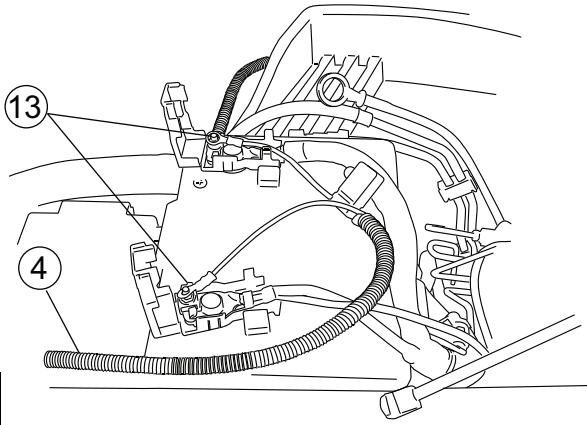

9

Mount controller to factory conduit using the two 11" cable ties.

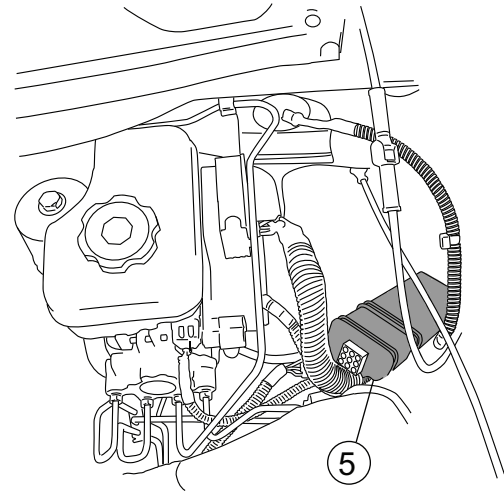

10

Route long end of wire harness across engine firewall and down through passenger wheel well. Route short end down drivers side wheel well. Use 7" cable ties to secure harness.

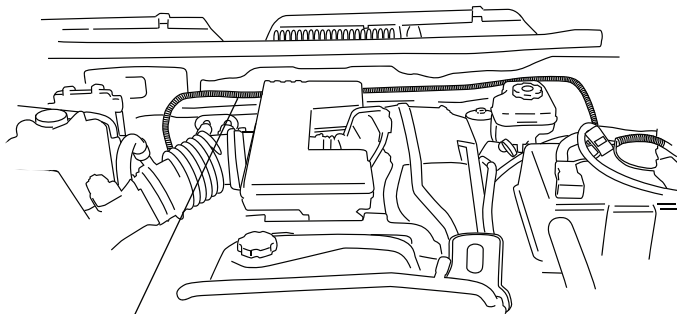

11

4

Route the wire harness along the frame, securing with cable ties. On passengers side route along outside of frame to avoid exhaust pipe.

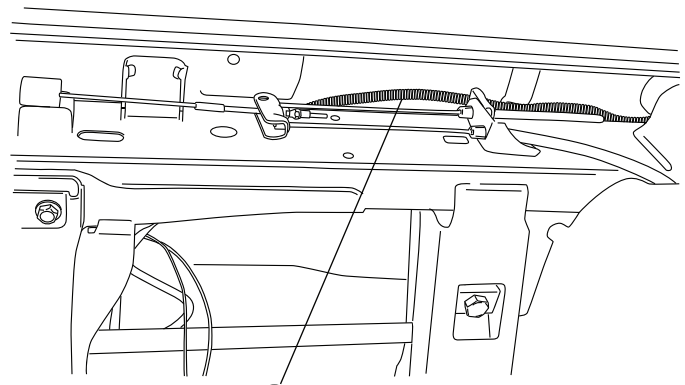

12

4

Repeat steps 7-12 on passengers side
 Insert plug from wire harness onto motor.

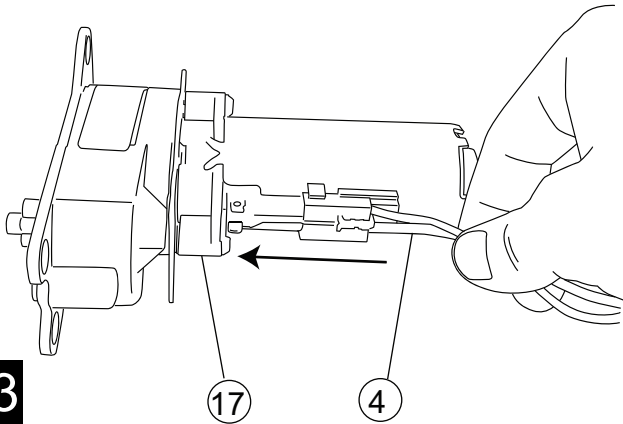

Slide rubber grommet on wire harness into slot of motor cover. Insert motor cover onto motor.

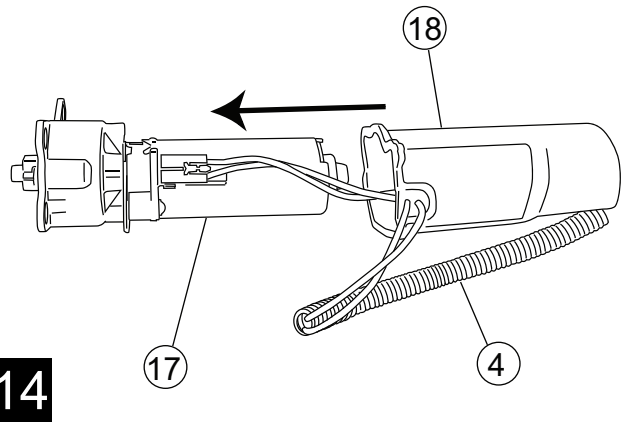

Insert plastic push pin rivets in mounting holes of motor cover.

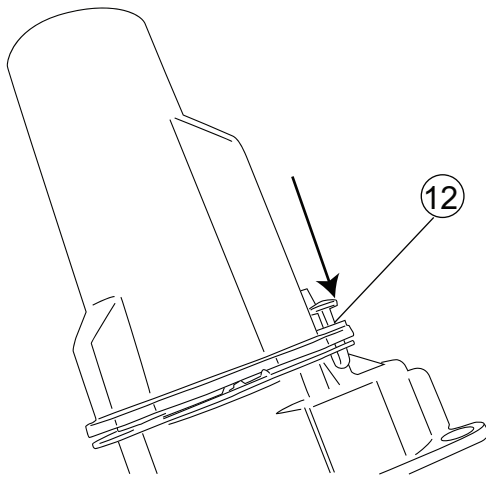

Install motor onto motor linkage assembly. Using two M6x16 Flat head screws to bolt linkage assembly.

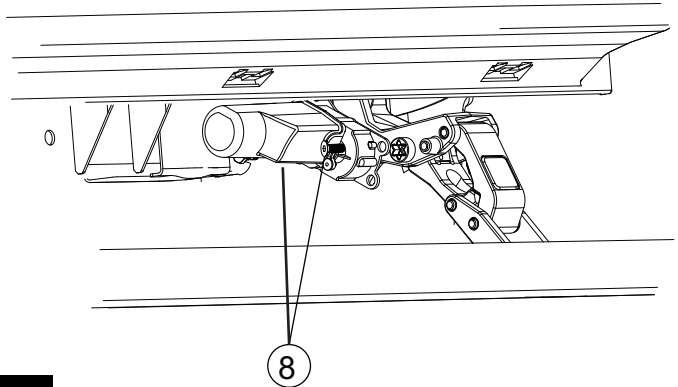

Repeat steps 7-16 on passengers side
 On drivers side; poke hole through rubber grommet near front door on underside of the floor pan with a philips screwdriver. Be careful not to go through carpet on other side.

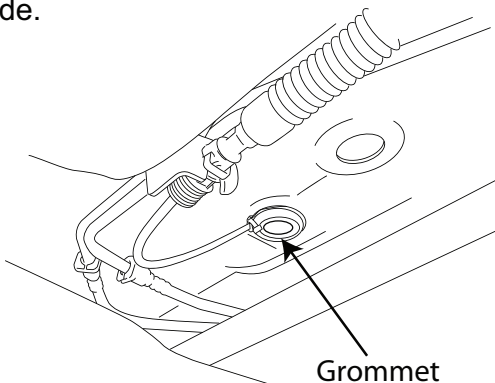

Feed trigger wires through hole

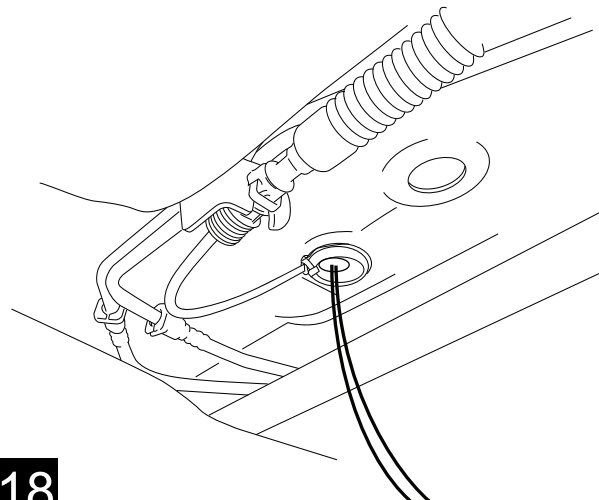

Carefully pull off the front threshold cover. It might be necessary to gently pry it off with a screwdriver.

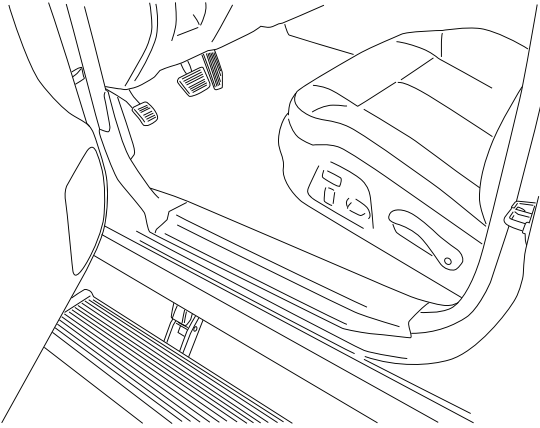

19

Carefully pull off the rear threshold cover. It might be necessary to gently pry it off with a screwdriver.

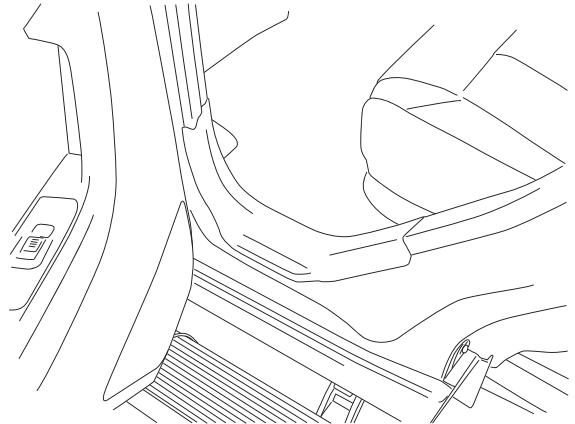

20

Pull up drivers side carpet and thread trigger wires through the floor. Seal wire and grommet with silicone sealer. Cover with tape to prevent sticking to carpet.

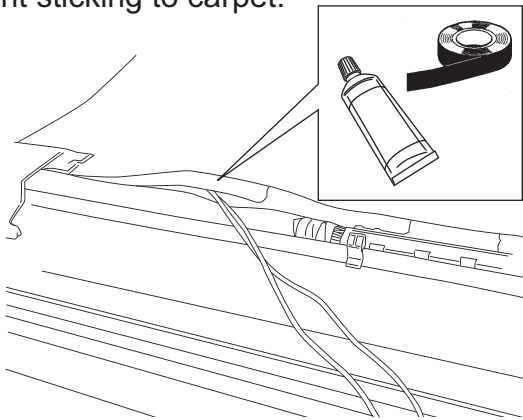

21

Posi-Tap™ instructions

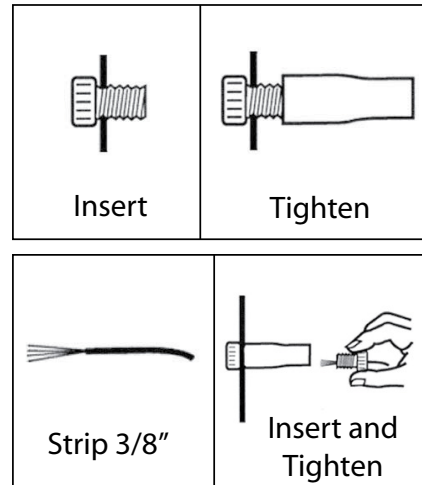

22

Locate factory wire harness going up B-pillar between doors on the driver side. Separate wires and locate the gray with black stripe wire. Using supplied Posi-Tap connector splice grey with black Power Step trigger wire to the grey with black stripe factory wire.

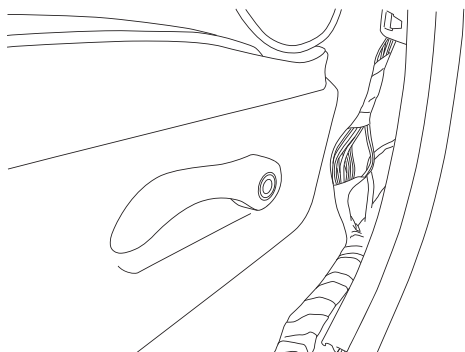

23

Locate the harness going up underneath the rear threshold cover. Pull wires apart to find the black with white stripe door ajar wire.

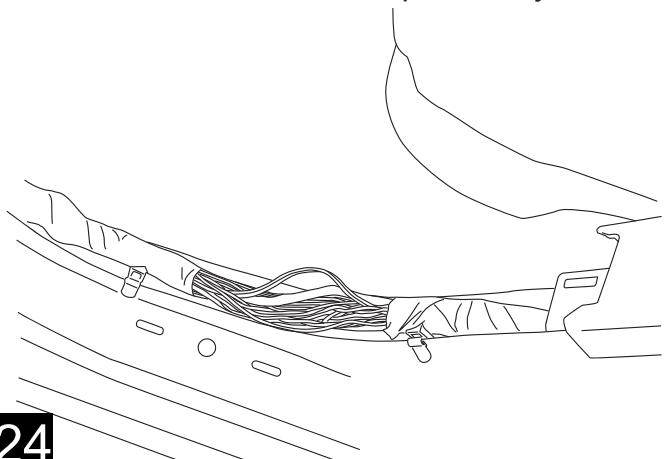

24

Using a test light, multi-meter or circuit tester determine if wire grounds when door is opened. There will be 2 wires that have black with white stripes that are constantly grounded; these are the incorrect wires.

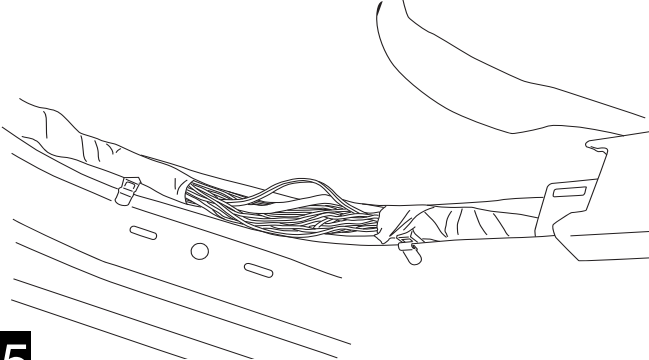

25

Attach single diode harness to black with white stripe trigger wire. Make sure diode is on side facing front of vehicle.

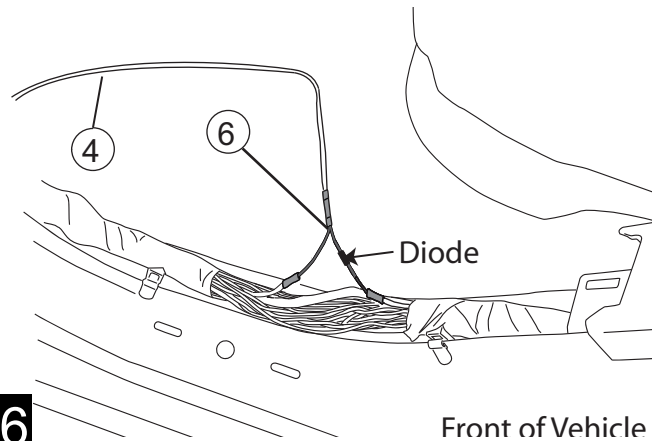

26

Front of Vehicle

Passengers side steps 20-28

Remove front and rear threshold covers. Move factory wire harness out of the way at front door.

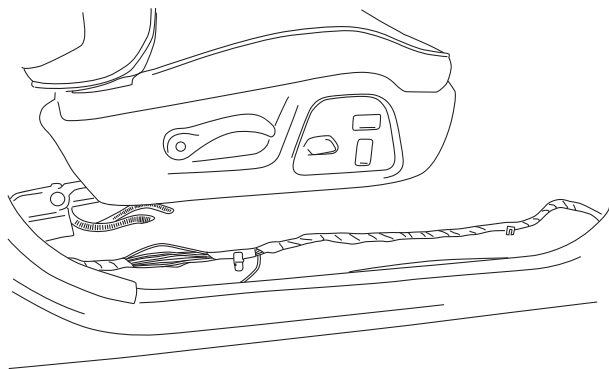

27

Drill a 9/32 hole in floorboard (see figure below). Be careful not to drill through carpet or wire harness on other side of floor pan.

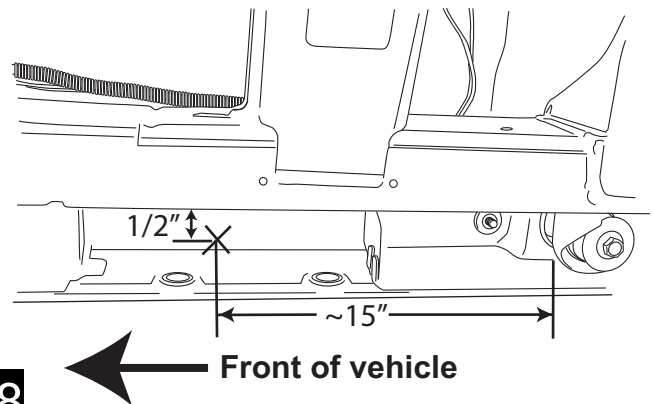

28

Front of vehicle

Install rubber grommet into hole and feed trigger wires through the grommet. Seal grommet with silicone and cover with tape to prevent it sticking to carpet.

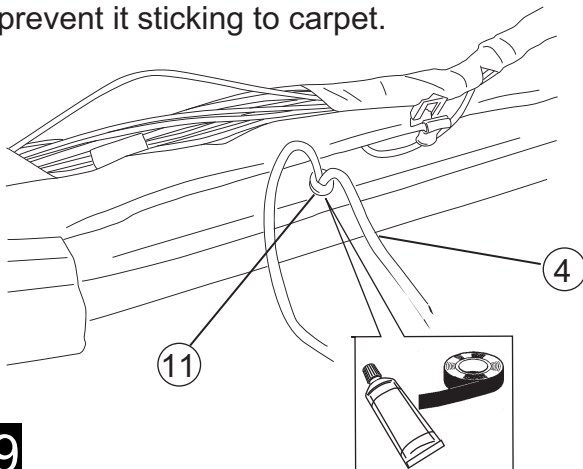

29

At front door locate green with black stripe door ajar wire in factory harness.

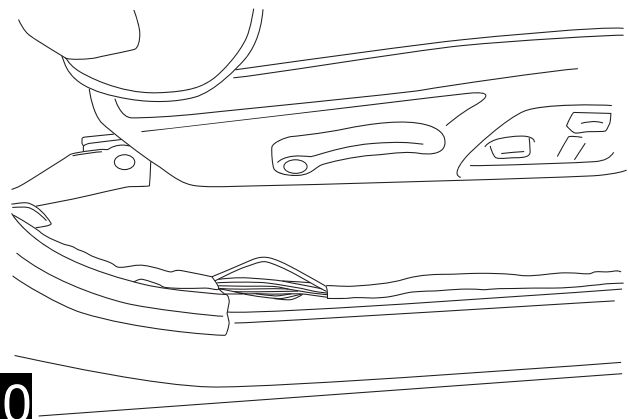

30

Attach single diode harness to green with black stripe trigger wire. Make sure diode is on side facing front of vehicle.

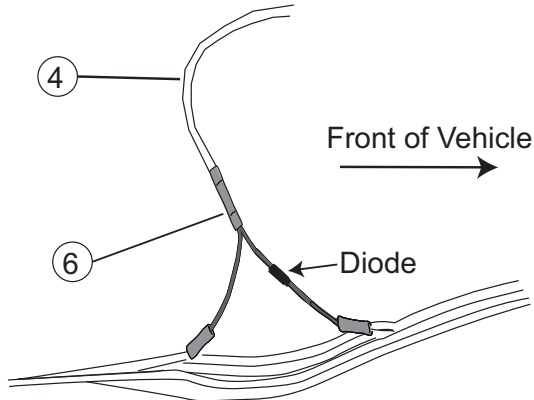

31

At passenger rear door locate the blue with black stripe wire(s) under the threshold cover. H3T will only have one blue with black stripe wire. Install a single diode harness as shown in step 33 then go to step 36.

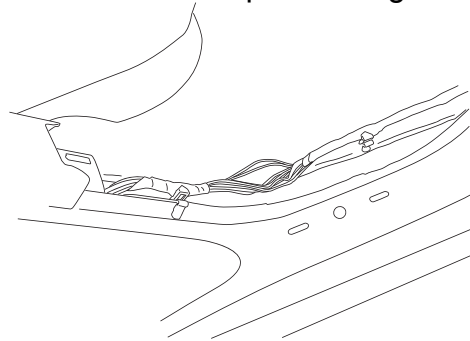

32

Attach single diode harness to each wire. Make sure diode is on side facing front of vehicle.

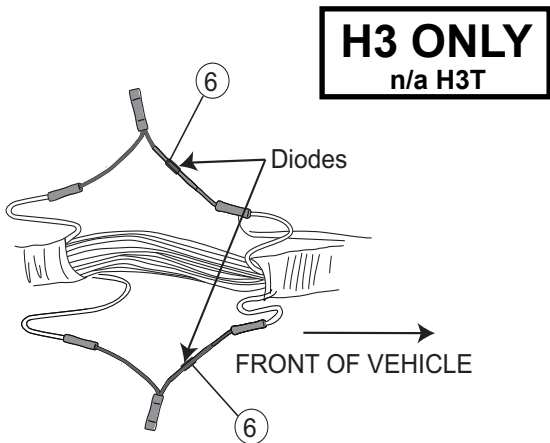

33

Remove rear passengers pin switch in door frame.

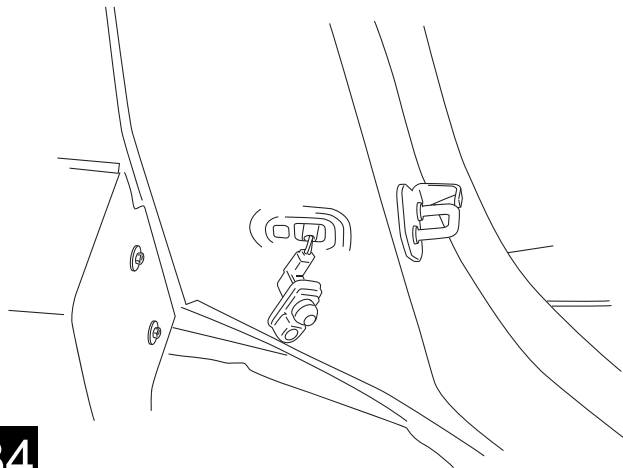

34

Determine which wire is from pin switch using a multi-meter or circuit tester. One wire will be for the rear hatch and one for the pin switch. Connect blue with back stripe trigger wire to the door pin wire.

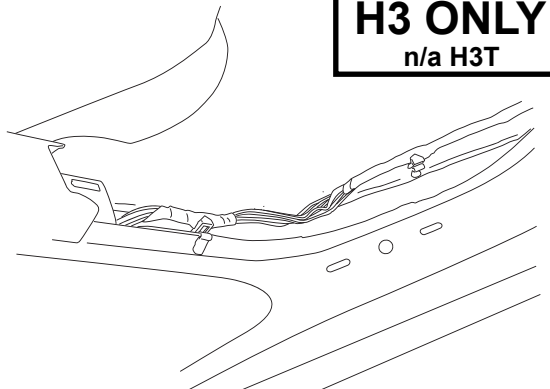

35

Reinstall fuse and check for proper operation by opening and closing all doors.

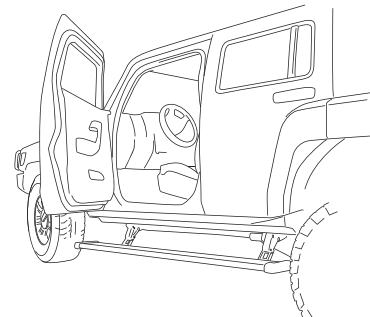
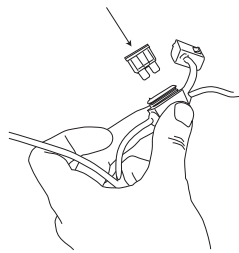

36

Congratulations on the purchase of your AMP Research Power Step



Here's what you should know...

OPERATION

The AMP Research Power Step automatically deploys when at least one door opens and automatically retracts under your vehicle when both front and rear doors close. If resistance or blockage is encountered while the Power Step is in motion, the drive system is designed to automatically stop. To reset, simply open or close the vehicle door and the Power Step will resume normal operation.

MAINTENANCE TIPS

The stepping surface and drive mechanism can be wash with mild soap and water using a soft brush or sponge to dislodge any mud, dirt or accumulated road grime. Rinse with fresh water.

To prevent slipping, avoid applying waxes, lubricants or protectants like Armor All® to the step surface.

When washing your vehicle, the Power Steps can be set to remain deployed with the doors closed for easy cleaning. Do this...

- 1** With the Power Step deployed, press and hold the board down with your foot.
- 2** Close the door while continuing to press down the board. (This will not harm motor.)
- 3** To reset the Power Step, simply open and close the door. (Repeat for both sides of vehicle.)

CAUTION! BE SURE TO KEEP HANDS AWAY WHEN THE POWER STEP IS IN MOTION.

amp-research.com

LIMITED WARRANTY

AMP RESEARCH warrants product to be free from defects in material and workmanship, for terms specified below, provided there has been normal use and proper maintenance. All remedies under this warranty are limited to the repair or replacement of any item found by the factory to be defective within the time period specified.

If you have a warranty claim, first you must call our factory at the number below for instructions. You must retain proof of purchase and submit a copy with any items returned for warranty work. Upon completion of warranty work, if any, we will return the repaired or replaced item or items to you freight prepaid. Damage to our products caused by accidents, fire, vandalism, negligence, misinstallation, misuse, Acts of God, or by defective parts not manufactured by us, is not covered under this warranty.

THE WARRANTY TIME PERIOD IS AS FOLLOWS: 5-YEARS FROM DATE OF PURCHASE.

ANY IMPLIED WARRANTIES OF MERCHANTABILITY AND/OR FITNESS FOR A PARTICULAR PURPOSE CREATED HEREBY ARE LIMITED IN DURATION TO THE SAME DURATION AND SCOPE AS THE EXPRESS WRITTEN WARRANTY. OUR COMPANY SHALL NOT BE LIABLE FOR ANY INCIDENTAL OR CONSEQUENTIAL DAMAGE.

Some states do not allow limitations on how long an implied warranty lasts, or the exclusion or limitation of incidental or consequential damages, so the above limitations or exclusions may not apply to you. This warranty gives you specific legal rights, and you may also have other rights that vary from state to state.

WARNING

Be sure to read and precisely follow the provided instructions when installing this product. Failure to do so could place the vehicle occupants in a potentially dangerous situation. After installing or reinstalling, re-check to insure that the product is