

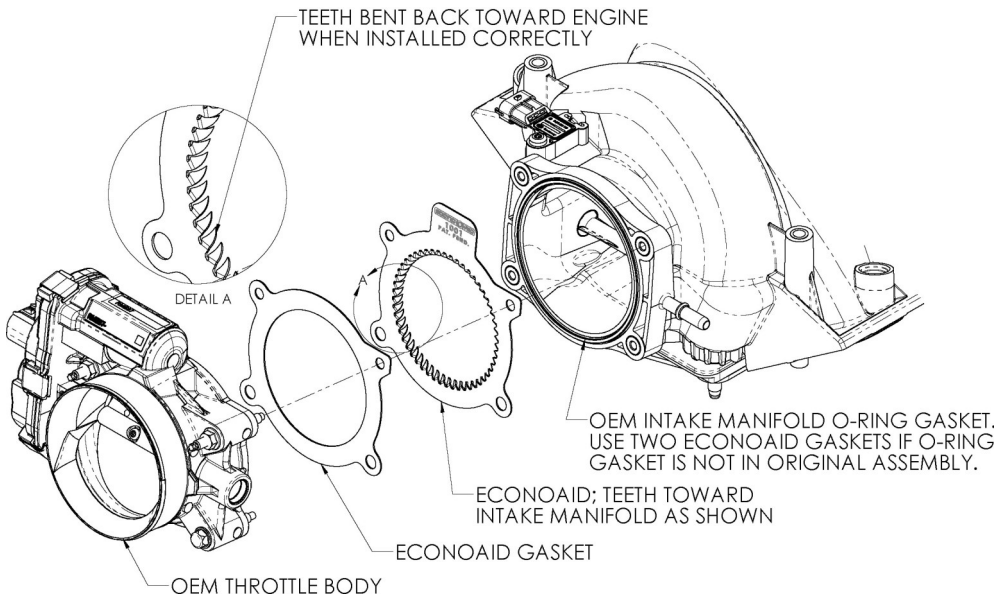

Part Number 1001

- 2007-13* Chevrolet Silverado
GMC Sierra
- 2009-14 Cadillac SUV & SUT
GMT-900 Trucks & SUVs
- 2005-13* Corvette
- 2009-12* Chevrolet Colorado
- 2005-06 Chevrolet SSR 6.0L
- 2005-09 Chevrolet Trailblazer
- 2005-09 GMC Envoy
- 2009-12 GMC Canyon
- 2008-09 Hummer H-2
- 2008-09 Hummer H-3 Alpha
- 2005-06 Pontiac GTO
- 2010-14* Chevrolet Camaro
4.8L, 5.3L, 6.0L, 6.2L Engines



Tools Required For Installation

- 5/16", 10mm Sockets
- Ratchet and Extension

Parts List

#1	ECONOAID	x1
#2	Gasket	x1

Thank you for purchasing the ECONOAID Throttlebody Booster. Please read the instruction manual carefully before proceeding with the installation. Contact ECONOAID @ (888) 876-4676 8:00 AM - 5:00 PM MST Weekdays for questions regarding fit or instructions that are not clear to you. Your ECONOAID Throttlebody Booster was carefully inspected and packaged. Check that no parts are missing, or were damaged during shipping. If any parts are missing, please contact ECONOAID.

U.S. Pat. #7,665,442



1. **Disconnect the negative battery cable!**
Lift up on the front of the and beauty cover and remove it from the vehicle. Push down on the radiator hose, and separate the intake tube from the plastic clamp.

2. Disconnect the breather tube from the intake tube, by gently pulling towards you. An O-ring is all that holds it in place.



3. Next loosen the hose clamp on the intake tube at the throttle body, and at the Mass Air Sensor, and then remove the tube from the vehicle.

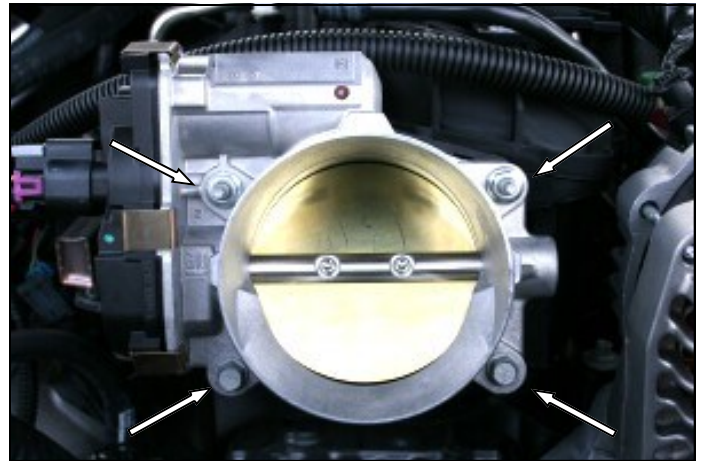

4. With a 10mm socket remove the two nuts, and the two bolts that hold the throttle body to the intake manifold. Without disconnecting the wiring harness, set the throttle body aside.



5. Install the ECONOAID Throttlebody Booster against the manifold over the studs with the logo facing the throttlebody. Next install the supplied gasket against the ECONOAID.

7. Reinstall the intake tube and tighten the two hose clamps. Next, reattach the intake tube to the radiator hose via the plastic clamp. Reinstall the breather tube into the intake tube. Reinstall the beauty cover.



6. Reinstall the throttlebody onto the intake manifold using the factory hardware. Tighten the nuts and bolts in a cross pattern to the vehicle manufacturer's specifications. Before starting the engine, open and close the throttlebody to make sure there are no obstructions.

8. Double check your work. Make sure there is no foreign material in the intake tract. Make sure all clamps, connectors, hoses, nuts, and bolts are secure.

Reconnect the negative battery cable.

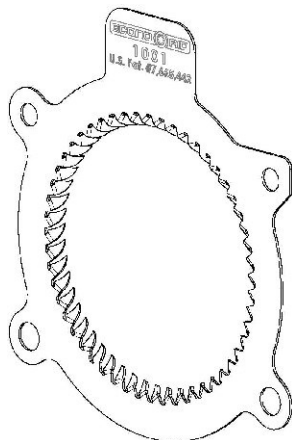

Instructions Revision
04.11.14