

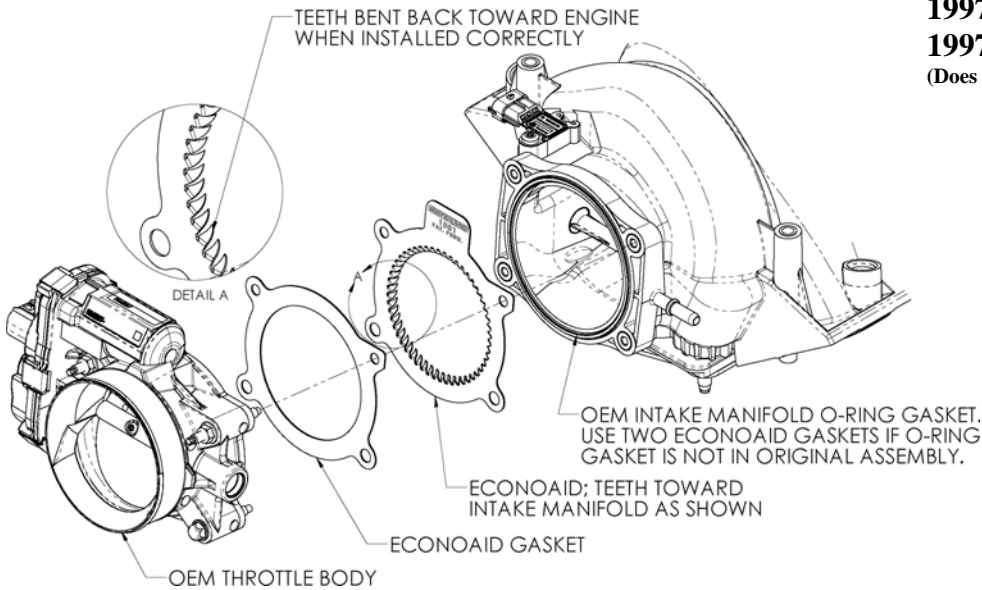

Part Number 1002

- 1997-03 Ford F-150 5.4L
 - 1997-04 Expedition 5.4L
 - 1999-04 Ford Super Duty 5.4L
 - 1997-06 Ford F-150 4.6L
 - 1997-04 Expedition 4.6L
- (Does Not Fit 2004 F-150 Heritage Model)



Tools Required For Installation

- 5/16", 10mm Sockets
- Ratchet and Extension

Parts List

#1	ECONOAID	x1
#2	Gasket	x2

Thank you for purchasing the ECONOAID Throttlebody Booster. Please read the instruction manual carefully before proceeding with the installation. Contact ECONOAID @ (888) 876-4676 8:00 AM - 5:00 PM MST Weekdays for questions regarding fit or instructions that are not clear to you. Your ECONOAID Throttlebody Booster was carefully inspected and packaged. Check that no parts are missing, or were damaged during shipping. If any parts are missing, please contact ECONOAID.

U.S. Pat. #7,665,442



1. **Disconnect the negative battery cable!**
Using a 10mm socket, remove three bolts, and the engine beauty cover. Next remove the air intake tube between the throttlebody and the air filter housing.

2. Remove the four bolts that hold the throttlebody to the intake manifold.

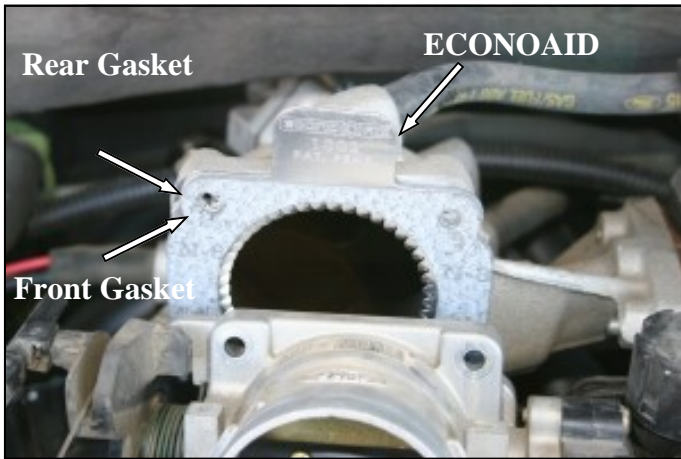

3. Pull the throttlebody away from the intake manifold, install the ECONOAID Throttlebody Booster against the intake manifold in between the two supplied gaskets with the logo facing the throttlebody. Reinstall the throttlebody onto the intake manifold using the factory hardware.

4. Before starting the engine, open the throttlebody to make sure that there are no obstructions.

5. Reinstall the intake tube and beauty cover. Double check your work! Make sure all nuts, bolts, hoses, clamps, and connectors are tight.

Re connect the negative battery cable!

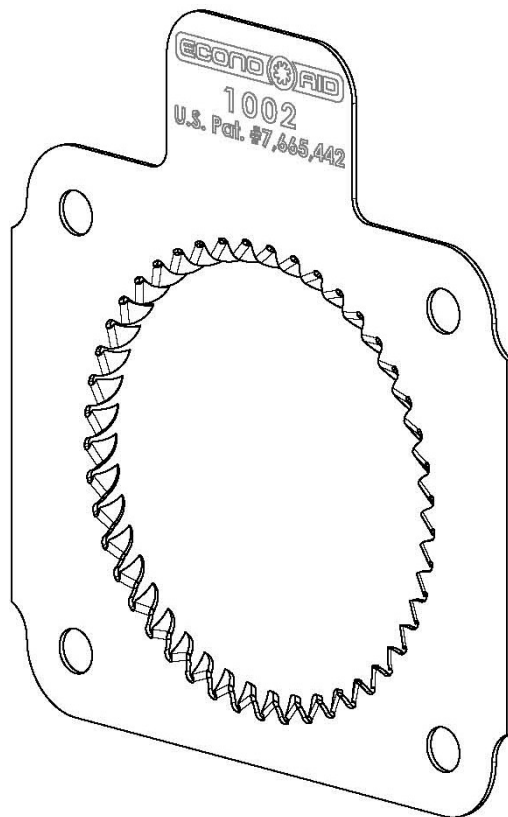

Included with your ECONOAID Throttlebody Booster is a decal with the California Air Resources Board (C.A.R.B.) Executive Order number D-520-4. This decal must be placed in plain view inside the engine compartment. Failure to do may prevent you from passing a smog inspection.

Instructions Revision
11/11/10