

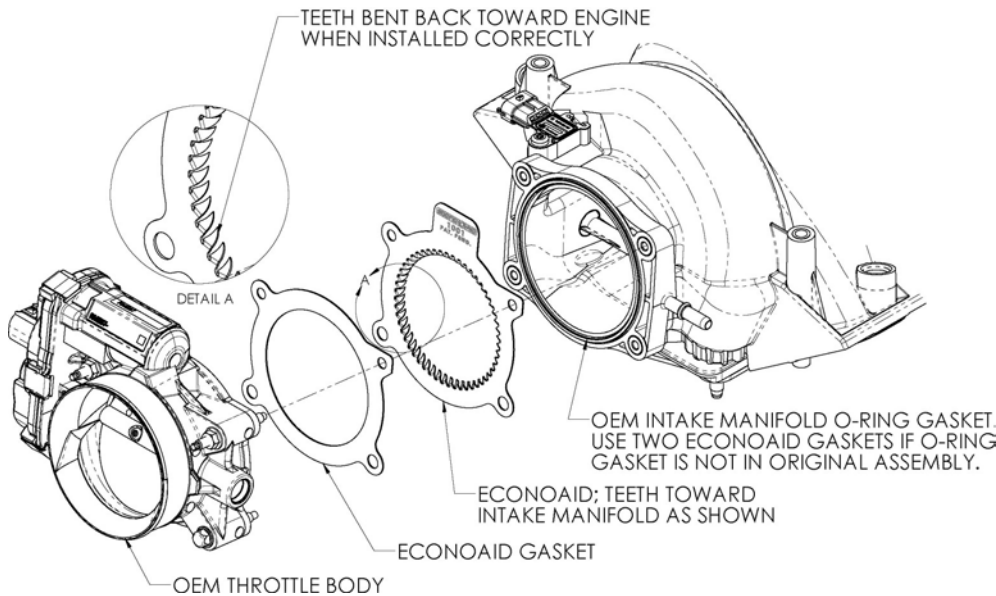

Part Number 1003

- 2007-09 Chrysler Aspen 5.7L
- 2005-15 Chrysler 300C
5.7L/6.1L SRT-8
- 2004-15 Dodge Durango 5.7L
- 2008-15 Dodge Challenger
5.7L/6.1L SRT-8 6.4I
- 2006-15 Dodge Charger
5.7L/6.1L/SRT-8 6.4L
- 2005-08 Dodge Magnum
5.7L/6.1L SRT-8
- 2003-15 Dodge Ram 5.7L
- 2006-15 Jeep Grand Cherokee
5.7L/ 6.1L/ SRT-8
- 2006-10 Jeep Commander 5.7L



Tools Required For Installation

5/16", 10mm Sockets
Ratchet and Extension

Parts List

#1	ECONOAID	x1
#2	Gasket	x1

Thank you for purchasing the ECONOAID Throttlebody Booster. Please read the instruction manual carefully before proceeding with the installation. Contact ECONOAID @ (888) 876-4676 8:00 AM - 5:00 PM MST Weekdays for questions regarding fit or instructions that are not clear to you. Your ECONOAID Throttlebody Booster was carefully inspected and packaged. Check that no parts are missing, or were damaged during shipping. If any parts are missing, please contact ECONOAID.

U.S. Pat. #7,665,442

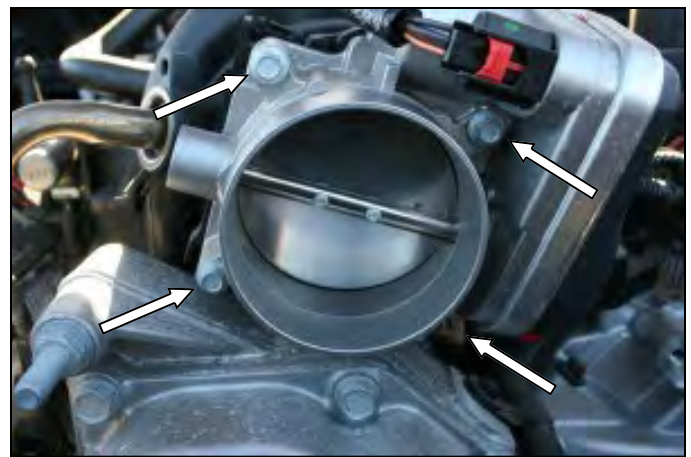

1. **Disconnect the negative battery cable!**
Lift up on the front of the engine beauty cover and remove it from the vehicle (If Equipped). Loosen two hose clamps, disconnect the air intake temperature sensor, and remove the air intake tube.

2. Using a 5/16" socket, remove the four bolts that hold the throttlebody to the intake manifold.

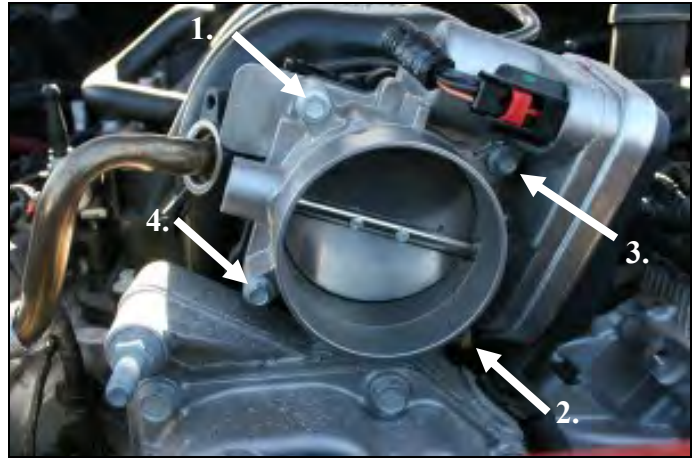
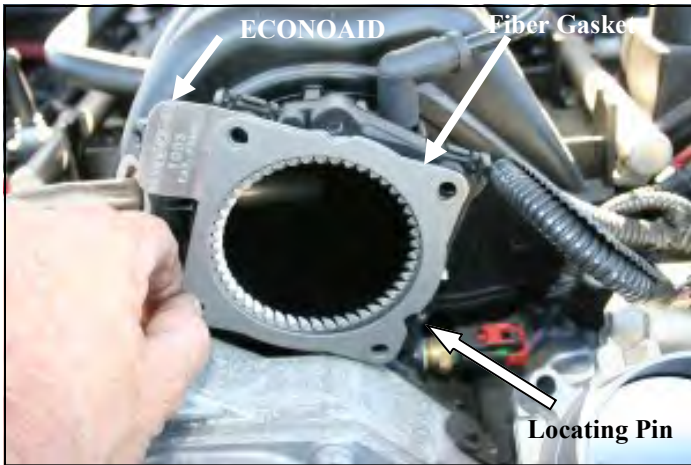

3. Install the ECONOAID Throttlebody Booster against the intake manifold with the logo facing the front of the vehicle and the supplied gasket on the throttlebody side of the plate. Make sure to align the two locating pins correctly with the notches in the ECONOAID and the gasket.

4. Reinstall the throttlebody using the factory bolts. Tighten them using a cross pattern to the manufacturer's specifications. Before starting the engine, open and close the throttlebody to make sure there are no obstructions.

5. Reinstall the intake tube and tighten the two hose clamps. Next, reconnect the wiring harness to the intake temperature sensor. Reinstall the engine beauty cover.

6. Double check your work. Make sure there is no foreign material in the intake tract. Make sure all clamps, connectors, hoses, nuts, and bolts are secure.

Reconnect the negative battery cable.

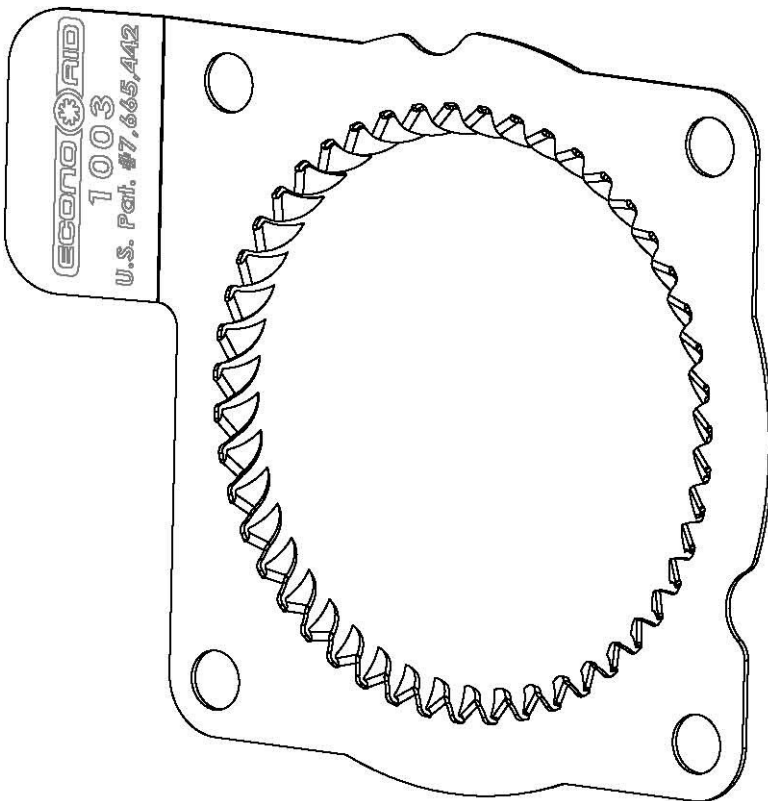

Instructions Revision
06.05.15