



Part Number 1005

2002-06 Cadillac Escalade 5.3L, 6.0L

2003-04 Chevrolet TrailBlazer
LT/GMC Envoy 5.3L

1996-00 Chevrolet/GMC C/K 7.4L

1997-04 Chevrolet Corvette 5.7L

1998-02 Chevrolet Camaro 5.7L

2003-04 Chevrolet SSR 5.3L

1999-06 GM Trucks and SUVs

2007 GM "Classic" Trucks
4.8L, 5.3L, 6.0L & 8.1L

2003-07 Hummer H-2 SUV & SUT

2004 Pontiac GTO 5.7L

1998-02 Pontiac Firebird 5.7L

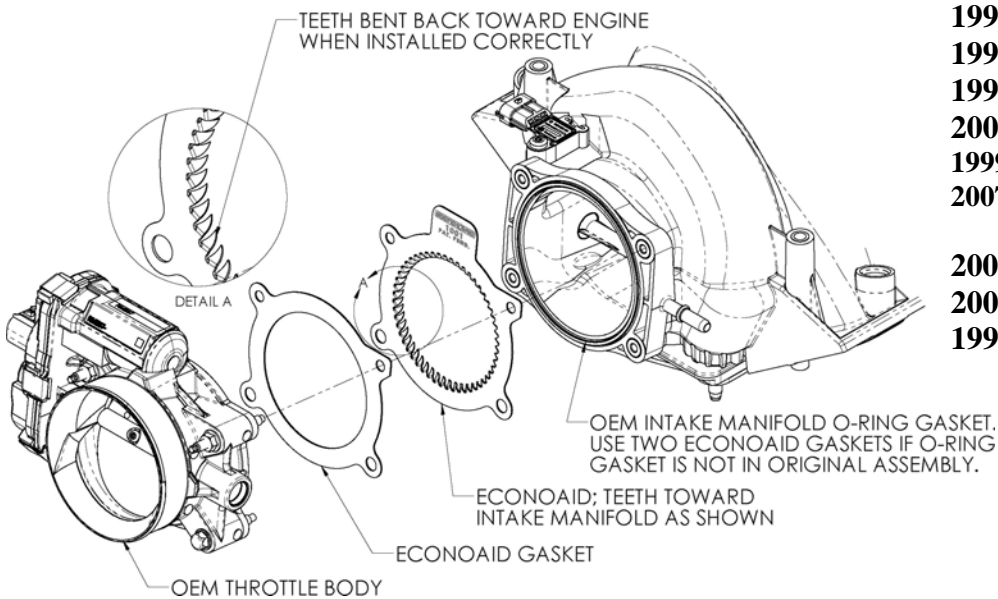

Tools Required For Installation

5/16", 4mm, 10mm Sockets

Ratchet and Extension

Parts List

| | | |
|----|----------|----|
| #1 | ECONOAID | x1 |
| #2 | Gasket | x2 |

Thank you for purchasing the ECONOAID Throttlebody Booster. Please read the instruction manual carefully before proceeding with the installation. Contact ECONOAID @ (888) 876-4676 8:00 AM - 5:00 PM MST Weekdays for questions regarding fit or instructions that are not clear to you. Your ECONOAID Throttlebody Booster was carefully inspected and packaged. Check that no parts are missing, or were damaged during shipping. If any parts are missing, please contact ECONOAID.

U.S. Pat. #7,665,442



1. **Disconnect the negative battery cable!** Loosen two hose clamps and remove the air intake tube. Separate the intake tube from the plastic clamp on the upper radiator hose. (If equipped).



2. Using a 10mm socket, remove the three nuts that hold the throttlebody to the intake manifold.

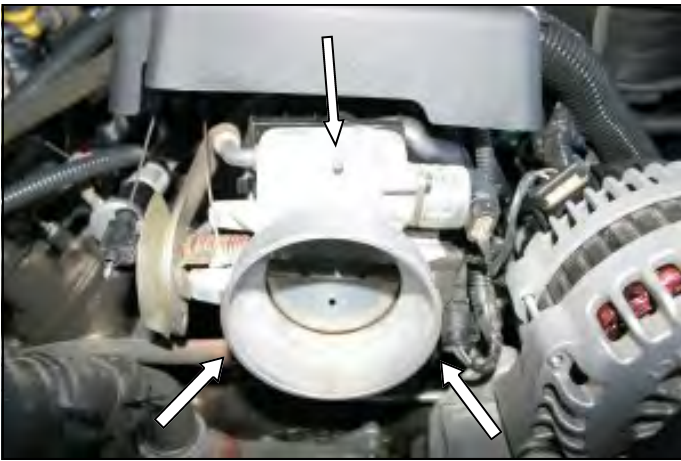

3. Using a 4mm socket, remove the three studs that go thru the throttlebody into the intake manifold



5. Now reinstall the three studs, and nuts and tighten them to the manufacturer's specifications. Before starting the engine, open and close the throttlebody to make sure there are no obstructions.

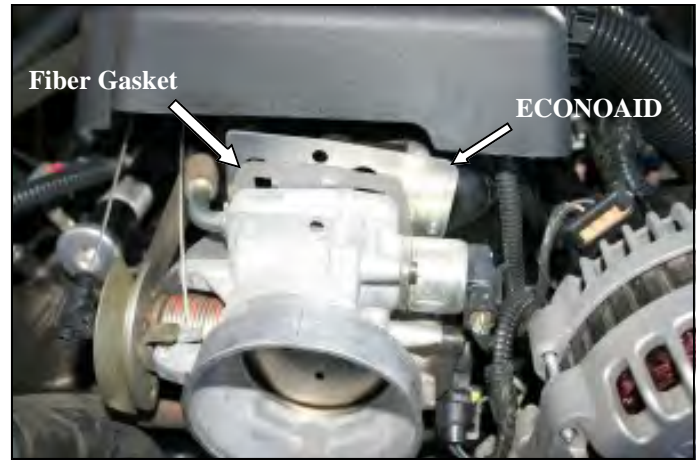

4. Pull the throttlebody towards you and install the ECONOAID Throttlebody Booster against the intake manifold with the logo facing the throttlebody. Next install the supplied gasket against the throttlebody. Make sure the holes in the gasket align with the holes in the ECONOAID. (If your vehicle does not have an O-ring in the face of the intake manifold, install the second supplied gasket between the ECONOAID and the manifold).

6. Reinstall the intake tube and tighten the two hose clamps. Next, reattach the intake tube to the radiator hose via the plastic clamp. (If equipped)

7. Double check your work. Make sure there is no foreign material in the intake tract. Make sure all clamps, connectors, hoses, nuts, and bolts are secure.

Reconnect the negative battery cable.

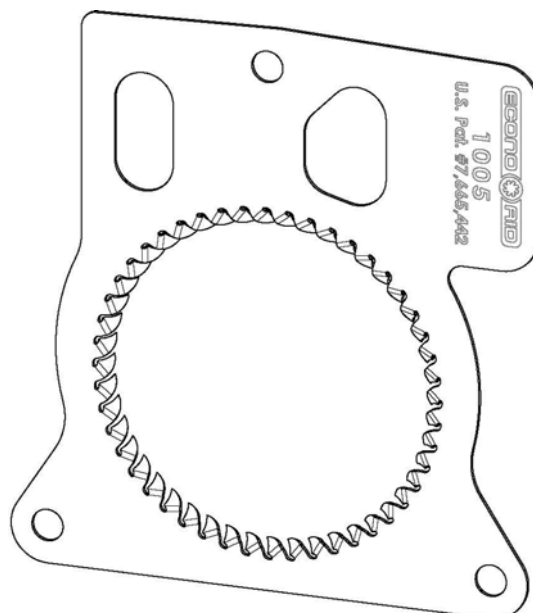

Included with your ECONOAID Throttlebody Booster is a decal with the California Air Resources Board (C.A.R.B.) Executive Order number **D-520-4**. This decal must be placed in plain view inside the engine compartment. Failure to do may prevent you from passing a smog inspection.

Instructions Revision
03/21/11