



# Part Number 1007

2004-14 Nissan Titan/Armada

2004-10 Infiniti QX56

5.6L Engine

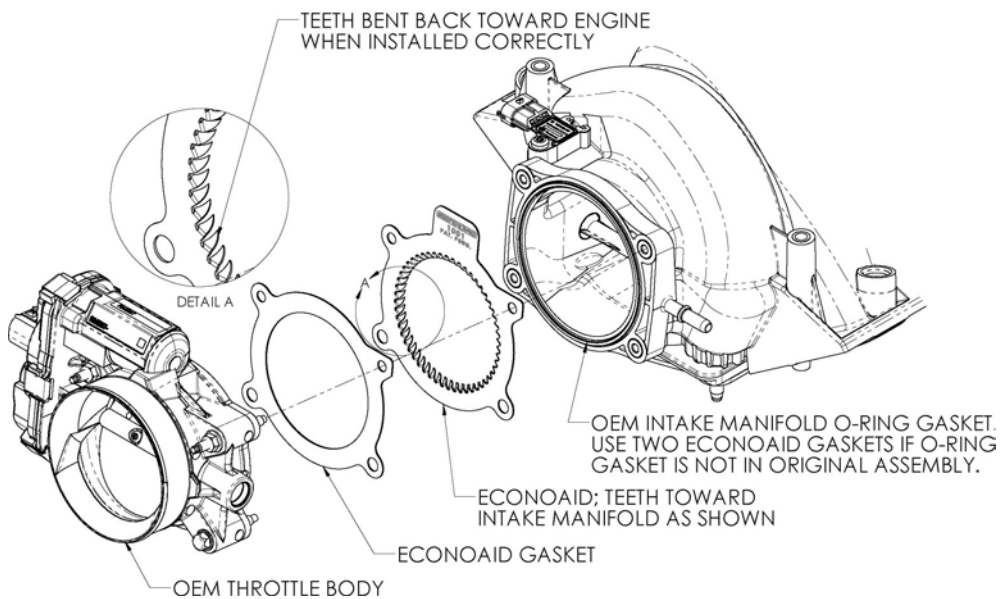

### Tools Required For Installation

- 5/16", 10mm Socket
- Ratchet and Extension
- 5mm Allen Bit or Wrench

### Parts List

#1	ECONOAID	x1
#2	Gasket	x1

Thank you for purchasing the ECONOAID Throttlebody Booster. Please read the instruction manual carefully before proceeding with the installation. Contact ECONOAID @ (888) 876-4676 8:00 AM - 5:00 PM MST Weekdays for questions regarding fit or instructions that are not clear to you. Your ECONOAID Throttlebody Booster was carefully inspected and packaged. Check that no parts are missing, or were damaged during shipping. If any parts are missing, please contact ECONOAID.

U.S. Pat. #7,665,442

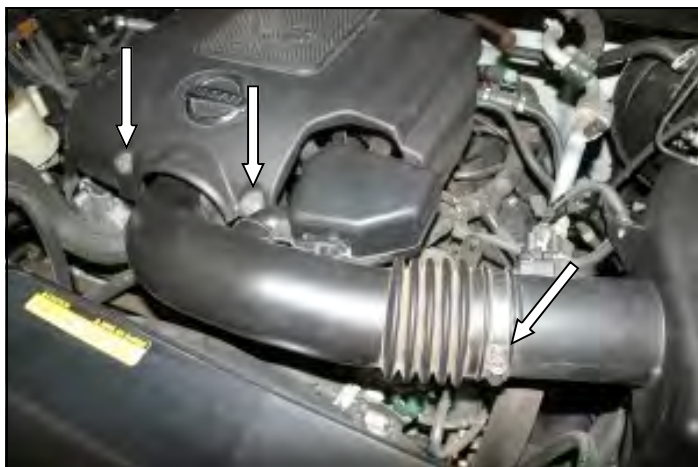

1. **Disconnect the negative battery cable!** Remove the two bolts that secure the engine beauty cover, and then remove it from the vehicle. Loosen the hose clamp that secures the air intake tube to the airbox.

2. Loosen the hose clamp that secures the air intake tube to the throttlebody and then remove the tube from the vehicle.



3. Remove the four bolts that hold the throttlebody to the intake manifold.



4. Install the ECONOAID Throttlebody Booster against the intake manifold with the logo facing the throttlebody. Next install the supplied gasket between the ECONOAID and the throttlebody.



5. Reinstall the factory bolts and tighten the bolts in a cross pattern to the manufacturer's specifications. Before starting the engine, open and close the throttlebody to make sure there are no obstructions.



6. Reinstall air intake tube between the throttlebody and the airbox and tighten the clamps. Reinstall the beauty cover and tighten the bolts.

7. Double check your work. Make sure there is no foreign material in the intake tract. Make sure all clamps, hoses, connectors, nuts, and bolts are secure.

**Reconnect the negative battery cable.**

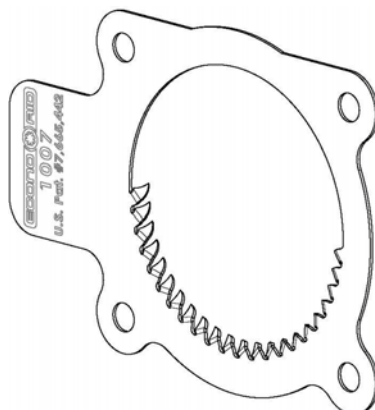

Instructions Revision  
02.13.15