

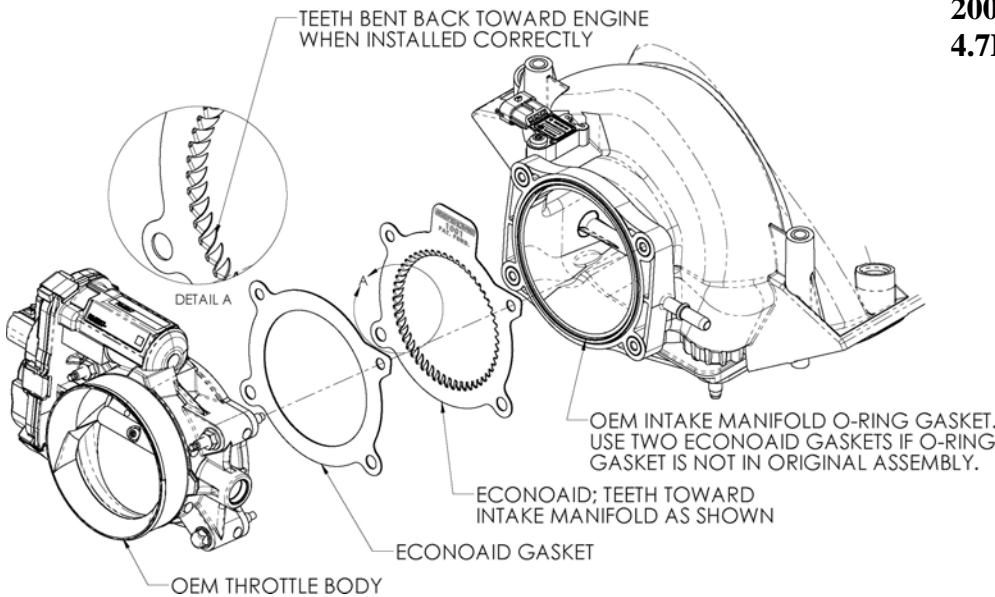

# Part Number 1011

2003-07 Dodge Ram  
2003-06 Dodge Dakota  
2003-06 Dodge Durango  
2003-06 Mitsubishi Raider  
4.7L V-8



### Tools Required For Installation

5/16", 10mm Sockets  
Ratchet and Extension

### Parts List

#1	ECONOAID	x1
#2	Gasket	x1

Thank you for purchasing the ECONOAID Throttlebody Booster. Please read the instruction manual carefully before proceeding with the installation. Contact ECONOAID @ (888) 876-4676 8:00 AM - 5:00 PM MST Weekdays for questions regarding fit or instructions that are not clear to you. Your ECONOAID Throttlebody Booster was carefully inspected and packaged. Check that no parts are missing, or were damaged during shipping. If any parts are missing, please contact ECONOAID.

U.S. Pat. #7,665,442



1. **Disconnect the negative battery cable!**  
Using a 5/16 socket, loosen the two hose clamps that secure the air intake tube between the airbox lid and the resonator. Remove the tube from the vehicle. Next, squeeze the tab, and disconnect the air intake temperature sensor wiring harness on the rear corner of the resonator.

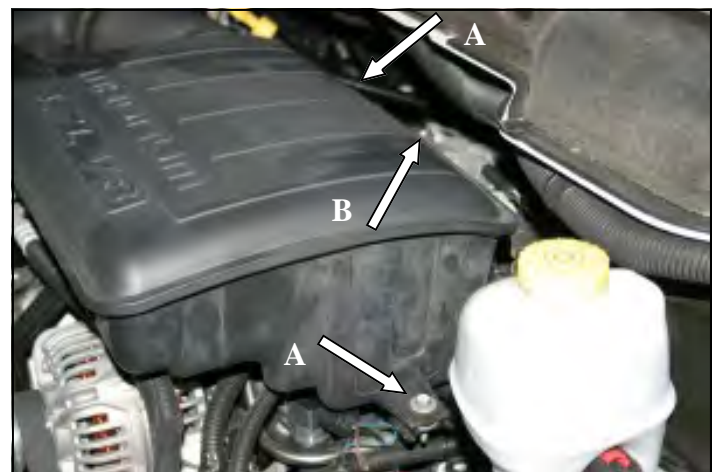

2. A.) Using a 10mm socket, remove the two bolts that secure the resonator to the engine. B.) Using a 5/16" socket, loosen the hose clamp that secures the rubber coupler on the back of the resonator to the throttlebody. Lift the front of the resonator straight up to disengage it from the mounting grommet, and remove the resonator assembly from the vehicle.

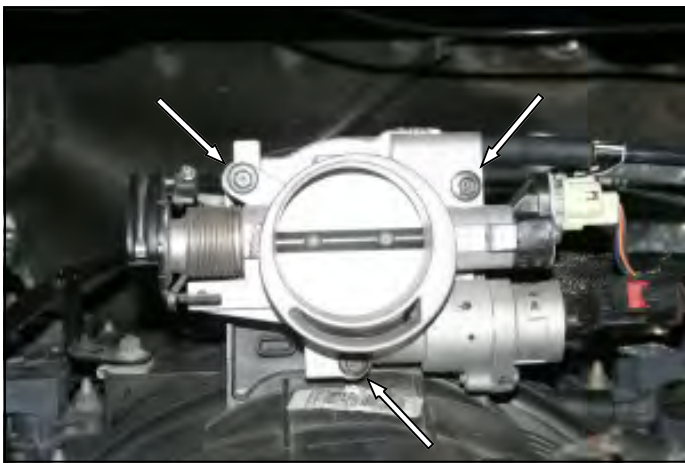

3. Remove the 3 bolts that secure the throttlebody to the intake manifold.

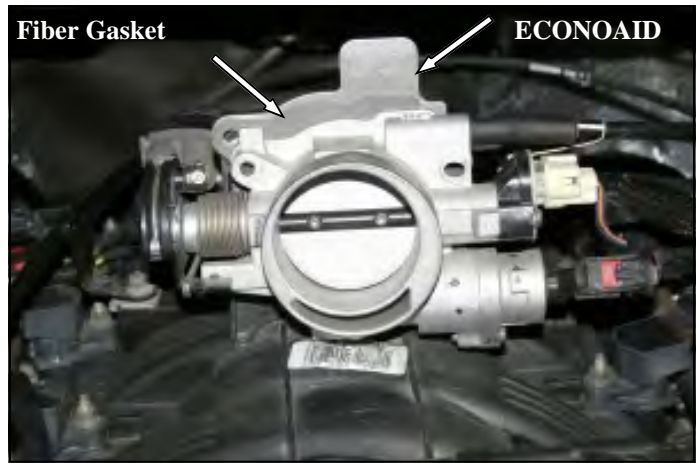

4. Install the supplied gasket between the ECONOAID Throttlebody Booster and the throttlebody making sure that the logo on the ECONOAID is facing the throttlebody.

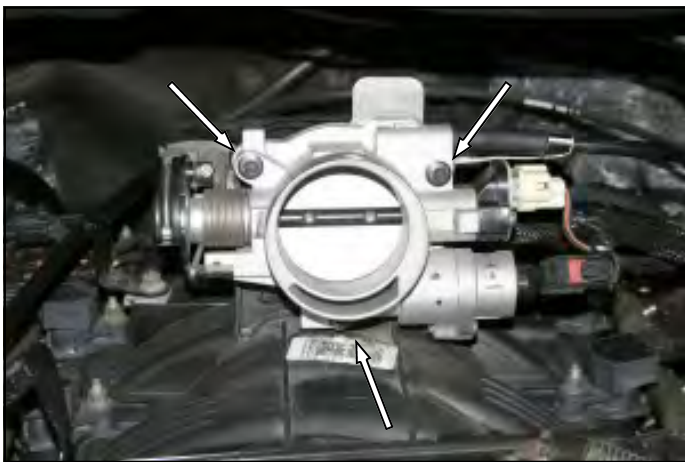

5. Reinstall the throttlebody onto the intake manifold and tighten all three bolts to the vehicle manufacturer's specifications. **Before starting the engine**, open and close the throttlebody to make sure there are no obstructions.



6. Reinstall the resonator and intake tube in the reverse order that they were removed. Make sure to reconnect the air temperature sensor.

7. Double check your work. Make sure there is no foreign material in the intake tract. Make sure all clamps, connectors, hoses, nuts, and bolts are secure.

**Reconnect the negative battery cable.**

Included with your ECONOAID Throttlebody Booster is a decal with the California Air Resources Board ( C.A.R.B. ) Executive Order number **D-520-4**. This decal must be placed in plain view inside the engine compartment. Failure to do may prevent you from passing a smog inspection.

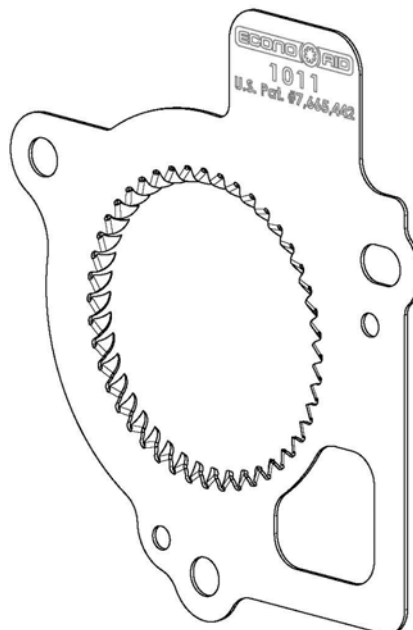

Instructions Revision  
11/12/10