

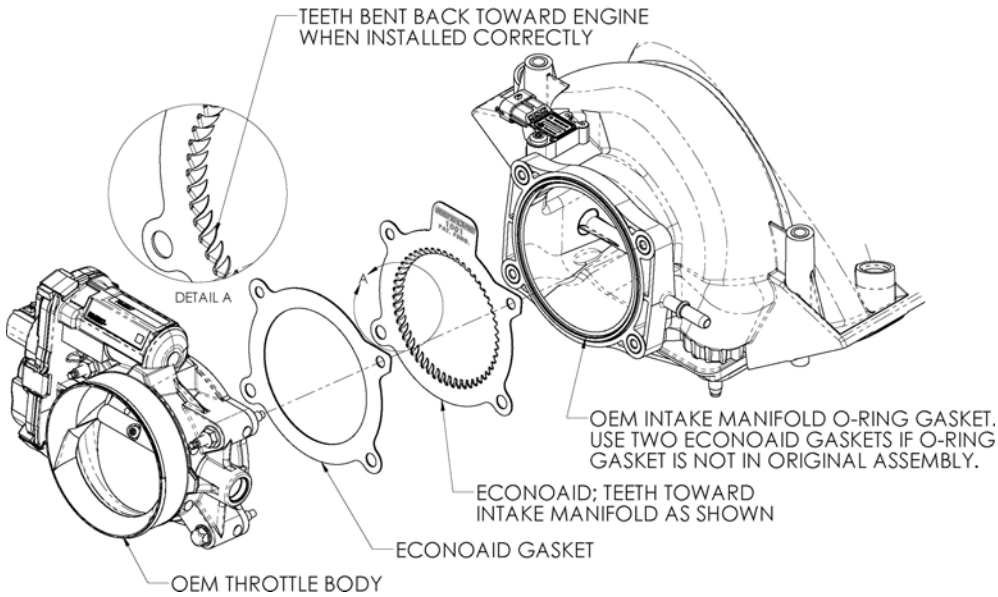

# Part Number 1013

1995-04  
1995-02

Toyota Tacoma  
Toyota 4Runner  
3.4L



**Tools Required For Installation**  
5/16", 10mm, 12mm, 13mm Sockets  
Ratchet and Extension

### Parts List

#1	ECONOAID	x1
#2	Gasket	x2

Thank you for purchasing the ECONOAID Throttlebody Booster. Please read the instruction manual carefully before proceeding with the installation. Contact ECONOAID @ (888) 876-4676 8:00 AM - 5:00 PM MST Weekdays for questions regarding fit or instructions that are not clear to you. Your ECONOAID Throttlebody Booster was carefully inspected and packaged. Check that no parts are missing, or were damaged during shipping. If any parts are missing, please contact ECONOAID.

U.S. Pat. #7,665,442

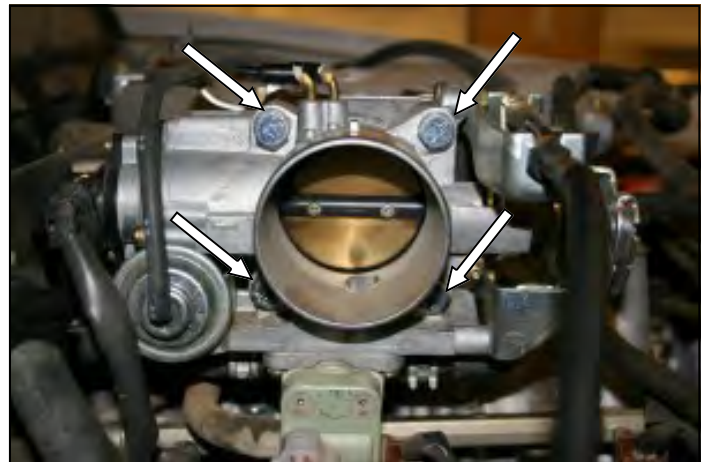

1. **Disconnect the negative battery cable!**  
Disconnect the crankcase breather hose from the intake tube. Loosen two hose clamps on the factory intake tube and remove it from the vehicle.

2. Remove the four bolts that hold the throttlebody to the intake manifold.

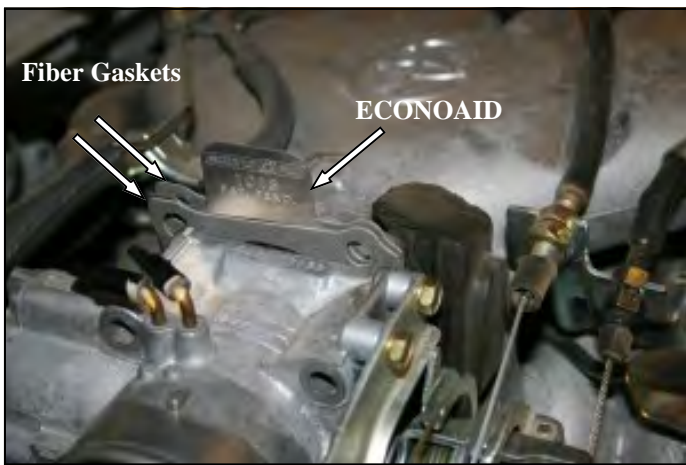

3. Install the ECONOAID Throttlebody Booster against the intake manifold with the logo facing the throttlebody. Next install the supplied gaskets, one on each side of the ECONOAID.

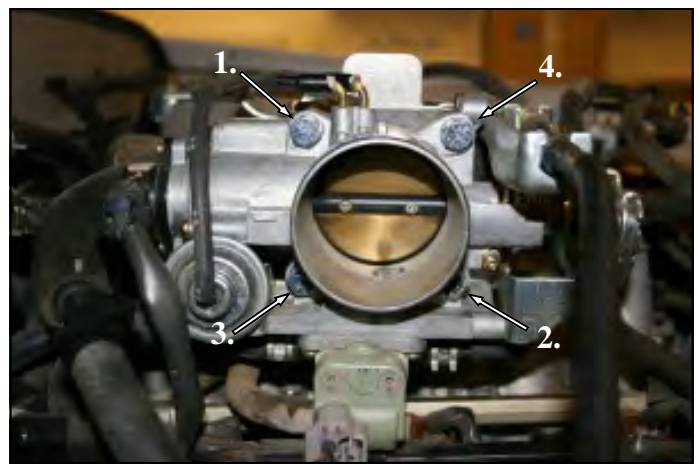

4. Reinstall the factory bolts and tighten them in a cross pattern to the manufacturer's specifications. Before starting the engine, open and close the throttlebody to make sure there are no obstructions.



5. Reinstall the intake tube and tighten the hose clamps. Reconnect the crankcase breather hose.

6. Double check your work. Make sure there is no foreign material in the intake tract. Make sure all clamps, hoses, connectors, nuts, and bolts are secure.

**Reconnect the negative battery cable.**

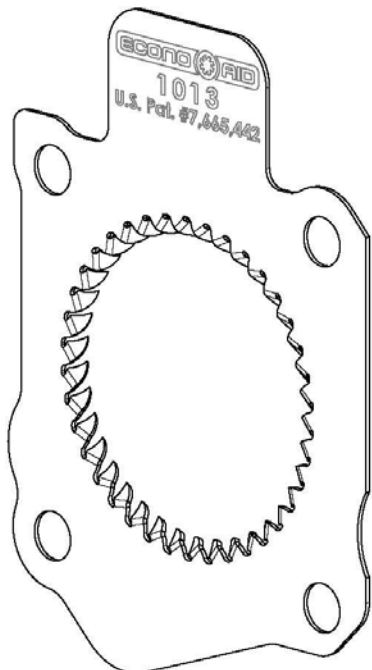

Included with your ECONOAID Throttlebody Booster is a decal with the California Air Resources Board ( C.A.R.B. ) Executive Order number **D-520-4**. This decal must be placed in plain view inside the engine compartment. Failure to do may prevent you from passing a smog inspection.

Instructions Revision  
11/12/10