

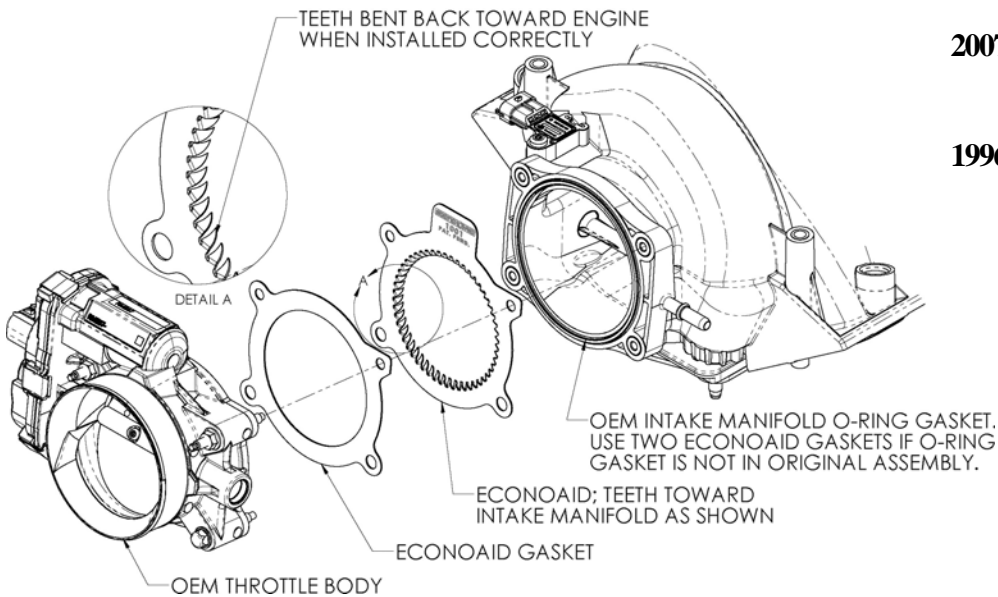

Part Number 1018

- 1996-00 Chevrolet, GMC Truck & SUV
5.7L V-8
- 1996-06 Chevy Silverado, GMC Sierra
4.3L V-6
- 2007 Chevrolet Silverado "Classic"
GMC Sierra "Classic"
4.3L V6
- 1996-04 Chevrolet S-10, GMC Sonoma
4.3L V6



Tools Required For Installation
 5/16" Deep, 5.5mm, 10mm Sockets
 Ratchet and Extension

Parts List

#1	ECONOAID	x1
#2	Gasket	x1

Thank you for purchasing the ECONOAID Throttlebody Booster. Please read the instruction manual carefully before proceeding with the installation. Contact ECONOAID @ (888) 876-4676 8:00 AM - 5:00 PM MST Weekdays for questions regarding fit or instructions that are not clear to you. Your ECONOAID Throttlebody Booster was carefully inspected and packaged. Check that no parts are missing, or were damaged during shipping. If any parts are missing, please contact ECONOAID.

U.S. Pat. #7,665,442

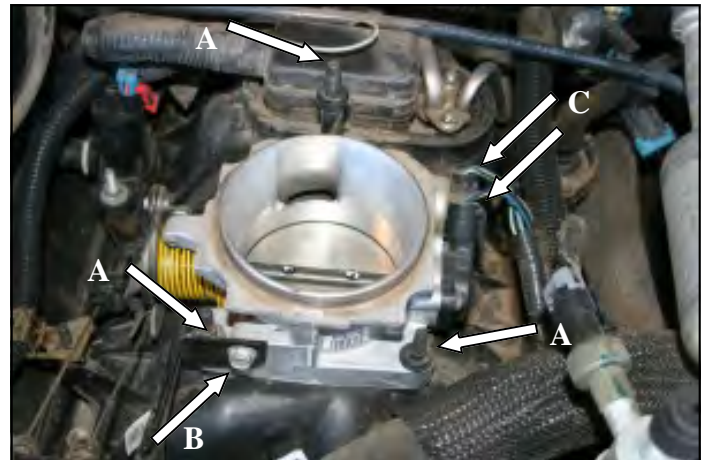

1. **Disconnect the negative battery cable!**
 Remove the plastic wing nut on the air intake hat behind the throttlebody. Loosen the hose clamp that secures the flexible intake tube to the throttle body hat. Disconnect the crankcase breather hose. Roll the air intake hat towards the front of the vehicle to remove it, and set it aside.

2. A.) Remove the three bolts that secure the throttlebody to the intake manifold. B.) Remove the bolt that secures the throttle cable bracket to the throttlebody. C.) Lift up the tabs, and disconnect the two wiring harnesses of the drivers side of the throttlebody. Lift the throttlebody off of the intake manifold and set it to the side.



3. Install the ECONOAID Throttlebody booster against the intake manifold with the logo facing the throttlebody. Next install the supplied gasket between the ECONOAID and the throttlebody.



4. Reinstall the throttlebody onto the intake manifold and tighten all three bolts to the vehicle manufacturer's specifications. Reconnect the two wiring harnesses. Reinstall the bolt thru the throttle cable bracket and into the throttlebody. Before starting the engine, open and close the throttlebody to make sure there are no obstructions.



5. Reinstall the intake hat and tighten the wing nut. Reconnect the crankcase breather hose. Reconnect the intake tube and tighten the clamp.

7. Double check your work. Make sure there is no foreign material in the intake tract. Make sure all clamps, connectors, hoses, nuts, and bolts are secure.

Reconnect the negative battery cable.

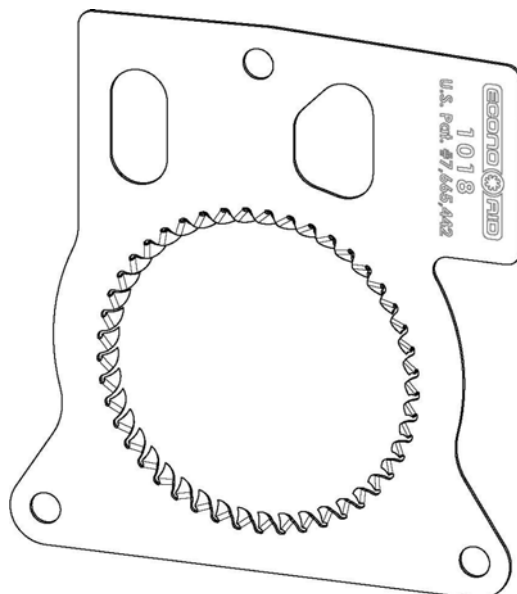

Included with your ECONOAID Throttlebody Booster is a decal with the California Air Resources Board (C.A.R.B.) Executive Order number **D-520-4**. This decal must be placed in plain view inside the engine compartment. Failure to do may prevent you from passing a smog inspection.

Instructions Revision
3/21/11