

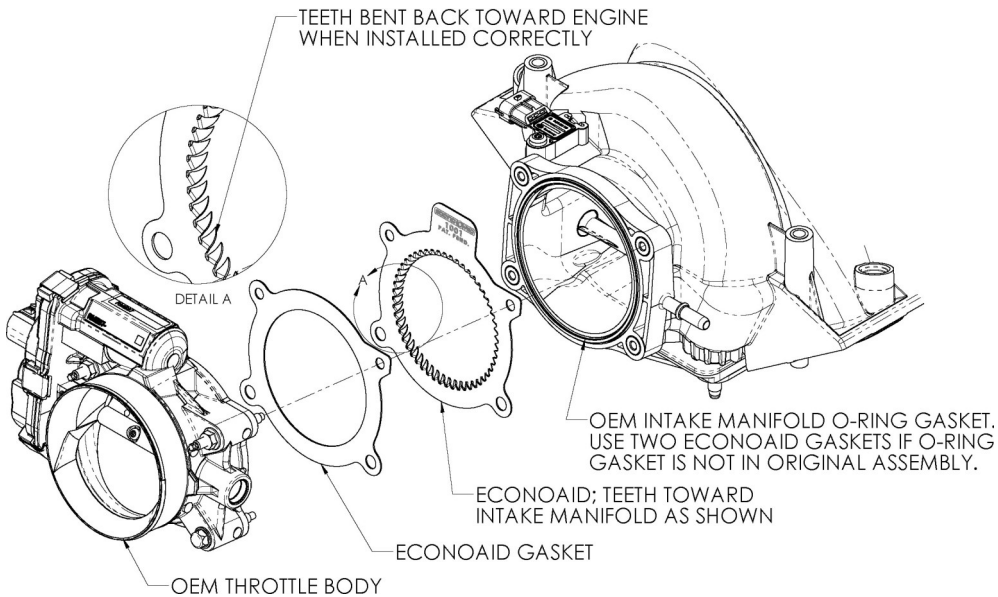

Part Number 1019

2003-09 Toyota 4Runner
 2005-15 Toyota Tacoma
 2007-09 Toyota FJ Cruiser
 4.0L V-6



Tools Required For Installation

10mm Socket
 Ratchet and Extension

Parts List

#1	ECONOAID	x1
#2	Gasket	x1

Thank you for purchasing the ECONOAID Throttlebody Booster. Please read the instruction manual carefully before proceeding with the installation. Contact ECONOAID @ (888) 876-4676 8:00 AM - 5:00 PM MST Weekdays for questions regarding fit or instructions that are not clear to you. Your ECONOAID Throttlebody Booster was carefully inspected and packaged. Check that no parts are missing, or were damaged during shipping. If any parts are missing, please contact ECONOAID.

U.S. Pat. #7,665,442

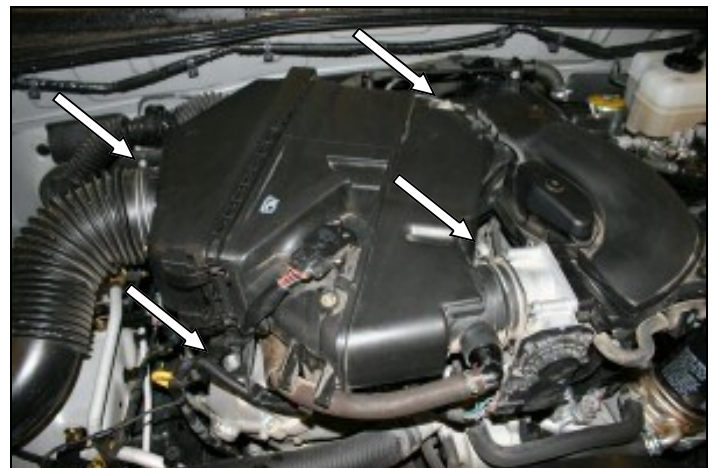
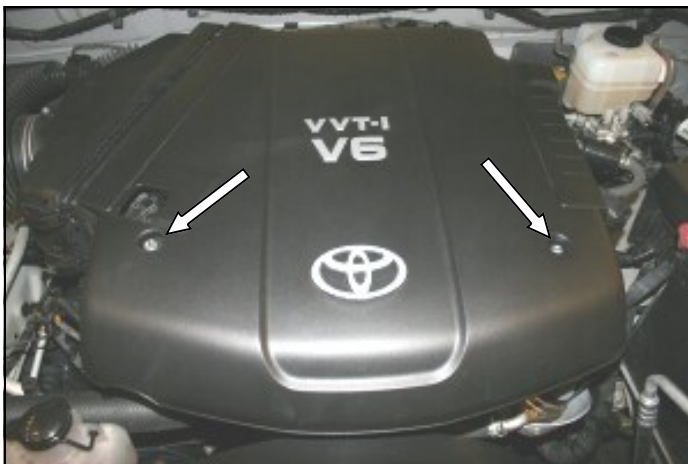

1. **Disconnect the negative battery cable!**
 Remove the two bolts that secure the engine beauty cover, and then remove it from the vehicle.

2. Loosen two hose clamps, one at the fresh air tube, and one at the throttlebody. Remove two bolts that secure the airbox to the engine.

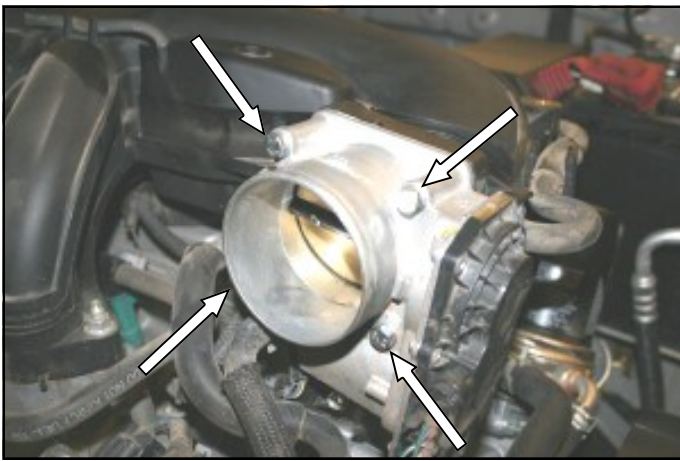

3. Remove the four bolts that hold the throttlebody to the intake manifold.

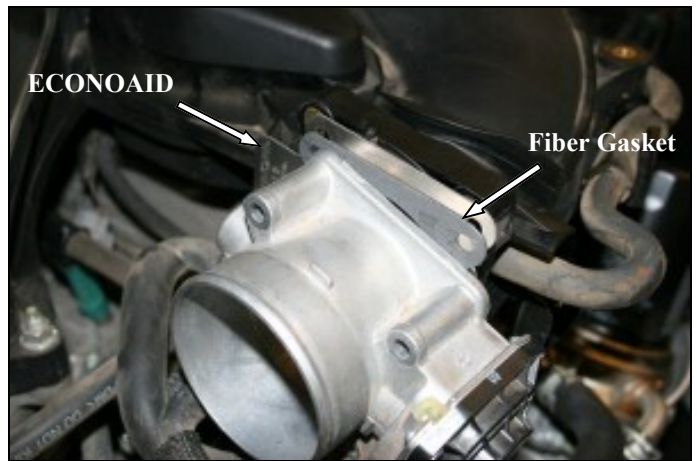

4. Install the ECONOAID Throttlebody Booster against the intake manifold with the logo facing the throttlebody. Next install the supplied gasket between the ECONOAID and the throttlebody.

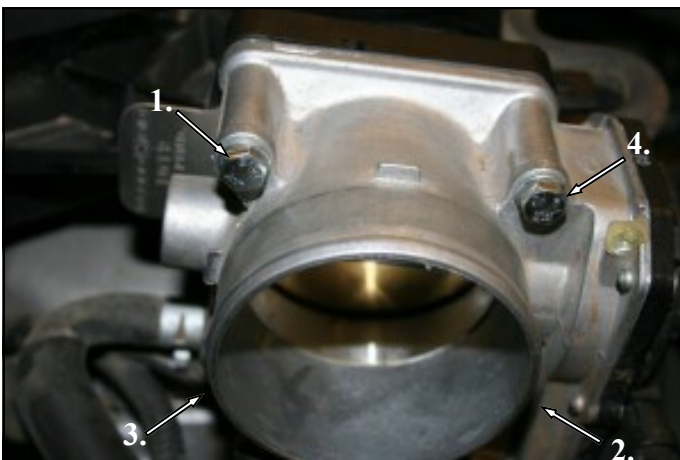

5. Reinstall the factory bolts and tighten the bolts in a cross pattern to the manufacturer's specifications. Before starting the engine, open and close the throttlebody to make sure there are no obstructions.

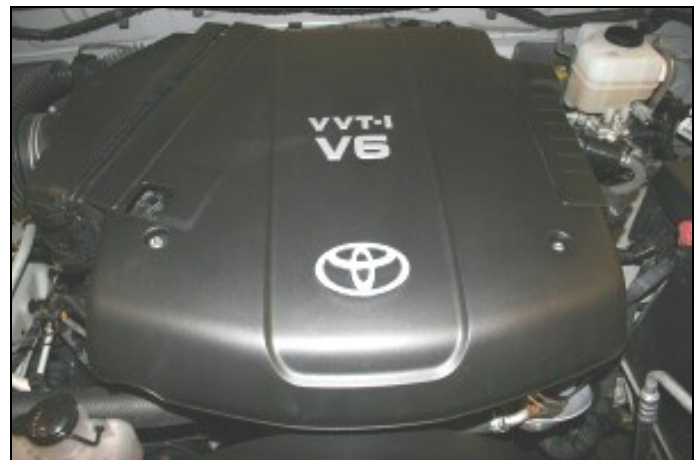

6. Reinstall the airbox onto the top of the engine and reconnect the fresh air tube. Reinstall the factory bolts and tighten the hose clamps. Reinstall the beauty cover.

7. Double check your work. Make sure there is no foreign material in the intake tract. Make sure all clamps, connectors, hoses, nuts, and bolts are secure.

Reconnect the negative battery cable.

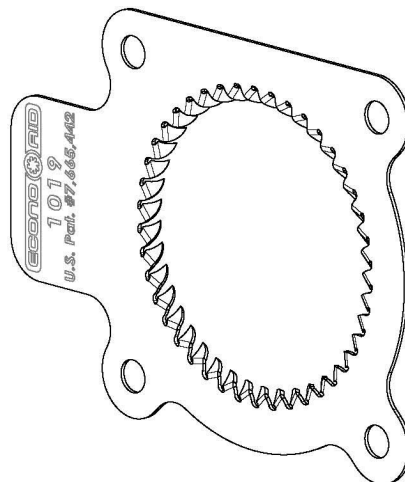

Instructions Revision
10.10.14