

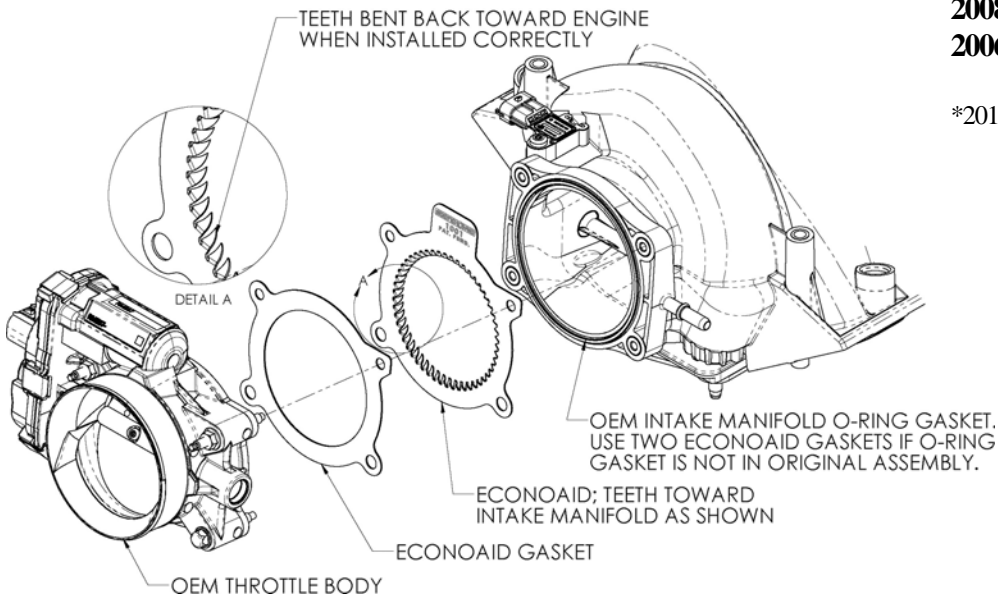

Part Number 1021

2003-09 Mazda3 2.0L & 2.3L (nonturbo)
 2003-08 Mazda6 2.0L & 2.3L (nonturbo)
 2006-09 Mazda5 2.3L
 2008-10* Ford Focus 2.0L
 2006-09 Ford Fusion/Mercury Milan 2.3L

*2010 model is not CARB legal



Tools Required For Installation

8mm, 10mm Sockets
 Ratchet and Extension
 Phillips Screwdriver

Parts List

#1	ECONOAID	x1
#2	Gasket	x1

Thank you for purchasing the ECONOAID Throttlebody Booster. Please read the instruction manual carefully before proceeding with the installation. Contact ECONOAID @ (888) 876-4676 8:00 AM - 5:00 PM MST Weekdays for questions regarding fit or instructions that are not clear to you. Your ECONOAID Throttlebody Booster was carefully inspected and packaged. Check that no parts are missing, or were damaged during shipping. If any parts are missing, please contact ECONOAID.

U.S. Pat. #7,665,442

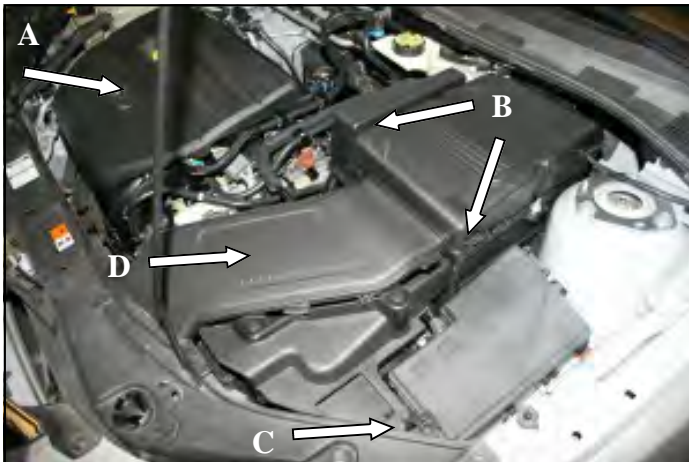

1. A.) Carefully lift straight up on the engine beauty cover and remove it from the engine. (*It is only held on by grommets.*)
 B.) Unsnap two clips and remove the plastic battery cover.
 C.) Remove one plastic screw, and then remove the plastic fresh air duct (D) from the vehicle.

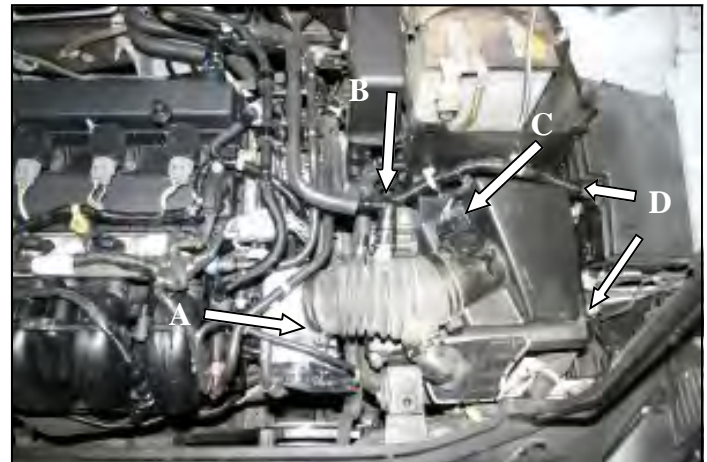

2. A.) Loosen the hose clamp that secures the air intake tube to the throttlebody. B.) Disconnect the crankcase breather from the air intake tube. C.) Disconnect the mass air sensor wiring connector from the mass air sensor on the air intake tube. D.) Unlatch the four clips (*one on each corner*) that secure the air cleaner lid to the lower airbox. Remove the air cleaner lid and flexible air intake tube from the vehicle as an assembly. Now remove the air cleaner from the lower airbox.

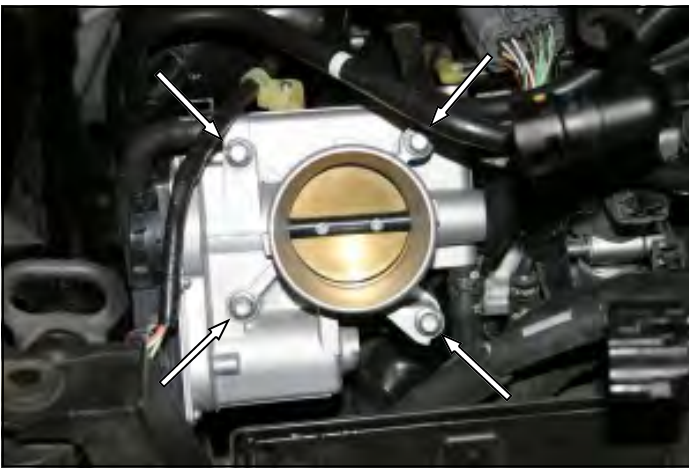

3. Remove the four bolts that secure the throttlebody to the intake manifold.



4. Pull the throttlebody away from the intake manifold. Install the ECONOAID Throttle Booster (*with the logo facing the throttlebody*) and the supplied gasket between the throttlebody and the intake manifold. The gasket needs to be between the intake manifold and the ECONOAID.



5. Make sure all of the holes are aligned, and then reinstall the factory bolts and tighten them to the factory specifications. Before starting the engine, open and close the throttlebody to make sure there are no obstructions. Reinstall the intake tube, air cleaner lid, fresh air duct, battery cover, and the beauty cover in the reverse order that they were removed.

6. Double check your work. Make sure there is no foreign material in the intake tract. Make sure all clamps, connectors, hoses, nuts, and bolts are secure.

Included with your ECONOAID Throttlebody Booster is a decal with the California Air Resources Board (C.A.R.B.) Executive Order number **D-520-4**. This decal must be placed in plain view inside the engine compartment. Failure to do may prevent you from passing a smog inspection.

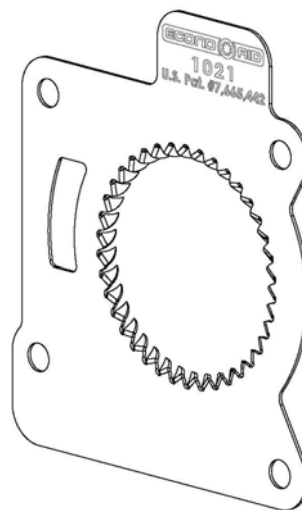

Instructions Revision
11/12/10