



Part Number 1022

2008-11 Dodge Dakota
 2008-12 Dodge Ram
 2008-09 Dodge Durango
 2008-09 Chrysler Aspen
 2008-10 Jeep Cherokee and
 Jeep Commander

4.7L Corsair V8

2012-15 Jeep Wrangler
 2012-14 Dodge Avenger
 2012-14 Chrysler 200/300
 2012-14 Dodge Challenger/Charger
 2012-14 Dodge Caravan
 2012-14 Dodge Durango
 2012-14 Jeep Grand Cherokee
 2012-14 Dodge Journey
 2013-14 RAM 1500

3.6L Pentastar V6

Parts List

#1	ECONOAID	x1
#2	Gasket	x1

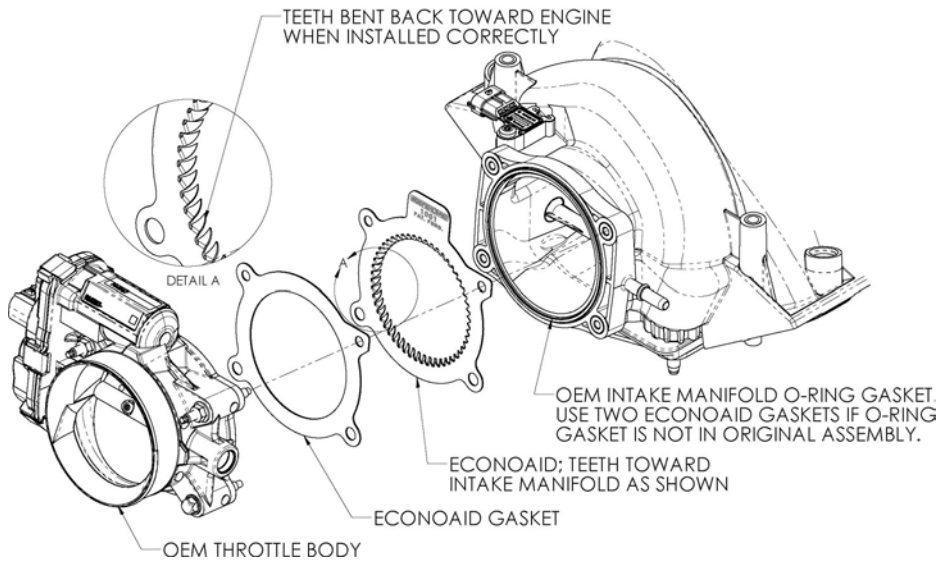

Thank you for purchasing the ECONOAID Throttlebody Booster. Please read the instruction manual carefully before proceeding with the installation. Contact ECONOAID @ (888) 876-4676 8:00 AM - 5:00 PM MST Weekdays for questions regarding fit or instructions that are not clear to you. Your ECONOAID Throttlebody Booster was carefully inspected and packaged. Check that no parts are missing, or were damaged during shipping. If any parts are missing, please contact ECONOAID.

U.S. Pat. #7,665,442

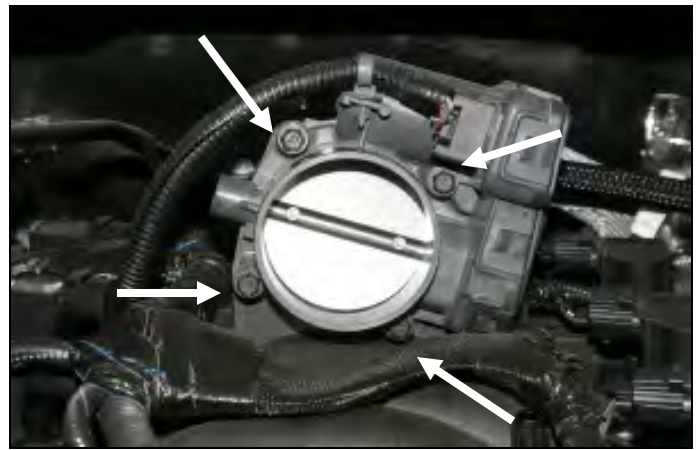
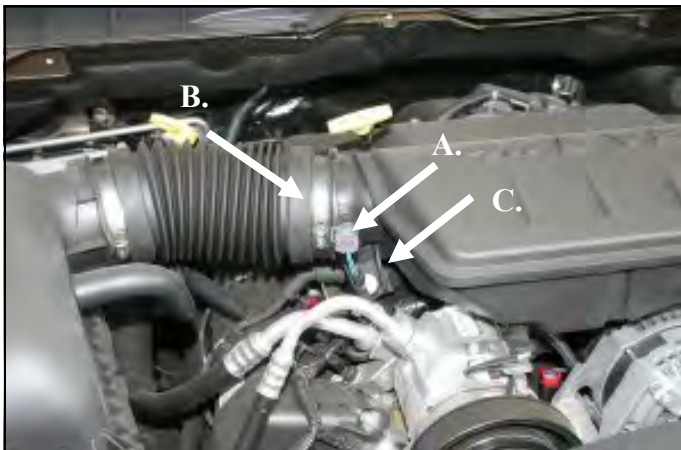

1. **Disconnect the negative battery cable!**
 - A.) Disconnect the intake air temperature sensor.
 - B.) Loosen the hose clamp that secures the flexible intake tube to the resonator.
 - C.) Loosen the bolt that secures the resonator to the intake manifold. Remove the resonator from the vehicle by lifting up on the front, and then pulling it towards the front of the vehicle.

2. Remove the four bolts that secure the throttlebody to the intake manifold. Remove the throttlebody from the intake manifold and set it aside. (No need to disconnect the wiring harness.)

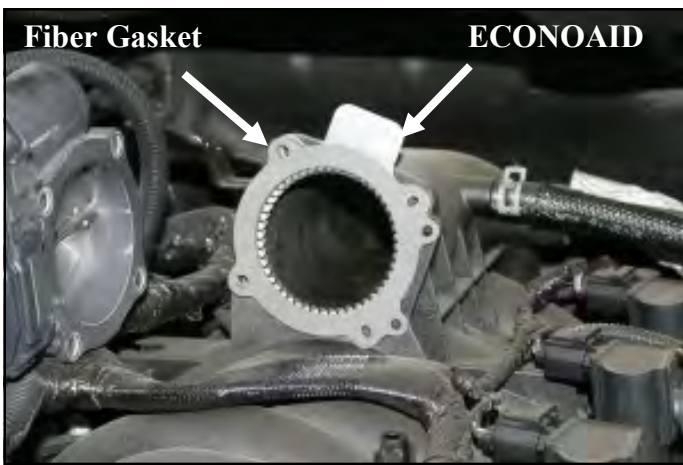

3. Install the ECONOAID Booster onto the intake manifold as shown. (The tab on the ECONOAID Booster may be rotated 90° to the left if desired.) Now install the gasket and make sure it is seated correctly over the two alignment pins on the intake manifold. Make sure the ECONOAID logo faces the throttlebody.

4. Reinstall the factory bolts thru the throttlebody and ECONOAID Booster and tighten to the manufacturer's specifications.



5. Reinstall the resonator and tighten the bolt that secures it to the intake manifold. Reinstall the intake tube, tighten the hose clamp, and reconnect the intake temperature sensor.

6. Double check your work. Make sure there is no foreign material in the intake tract. Make sure all clamps, connectors, hoses, nuts, and bolts are secure.

Reconnect the negative battery cable.

Re-connect the negative battery cable!

Included with your ECONOAID Throttlebody Booster is a decal with the California Air Resources Board (C.A.R.B.) Executive Order number **D-520-4**. This decal must be placed in plain view inside the engine compartment. Failure to do may prevent you from passing a smog inspection.

*2010-13 model years are not CARB Approved

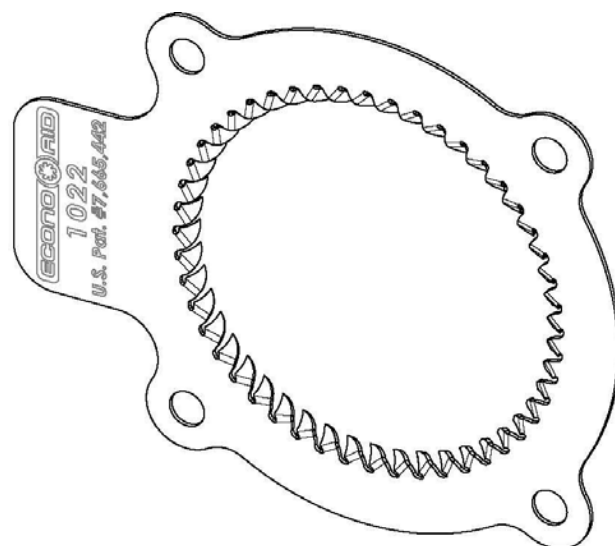

Instructions Revision
10.07.14