

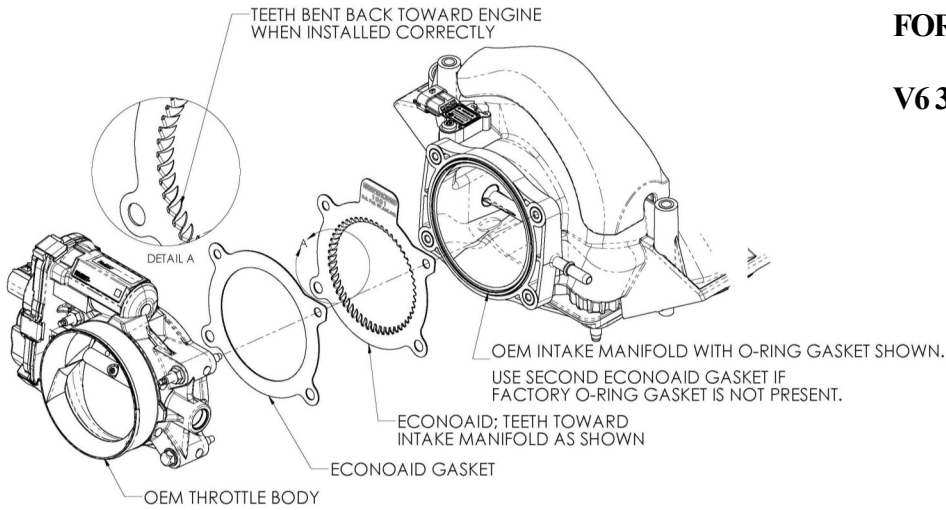

Part Number 1026

FORD F-150 PICKUP 2011-2014

V6 3.5L EcoBoost



Parts List

#1	ECONOAID	x1
#2	Gasket	x1

Thank you for purchasing the ECONOAID Throttlebody Booster. Please read the instruction manual carefully before proceeding with the installation. Contact ECONOAID @ (888) 876-4676 8:00 AM - 5:00 PM MST Weekdays for questions regarding fit or instructions that are not clear to you. Your ECONOAID Throttlebody Booster was carefully inspected and packaged. Check that no parts are missing, or were damaged during shipping. If any parts are missing, please contact ECONOAID.



U.S. Pat. #7,665,442

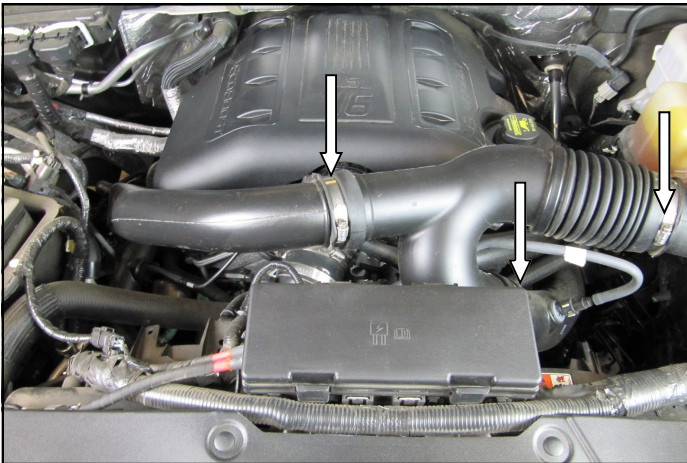

1. Locate and loosen the intake tube clamps. Remove the factory intake tube and set it aside. It may be necessary to remove the engine cover to gain access to the throttlebody on some applications.

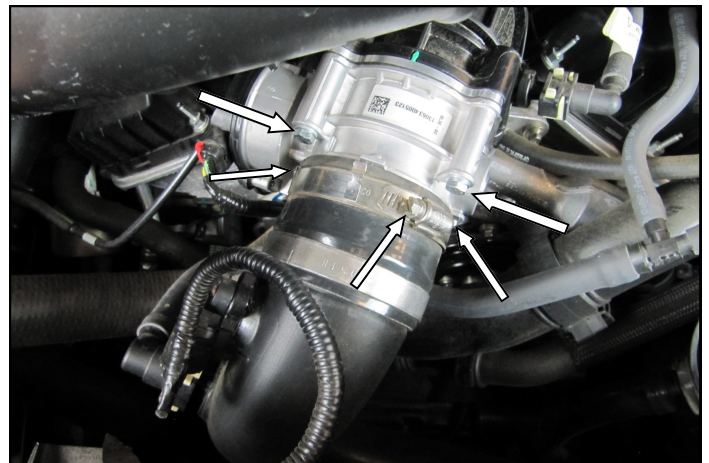

2. Loosen the clamp on the throttle body inlet tube and slide it away from the throttle body. Remove the four bolts that secure the throttlebody to the intake manifold.

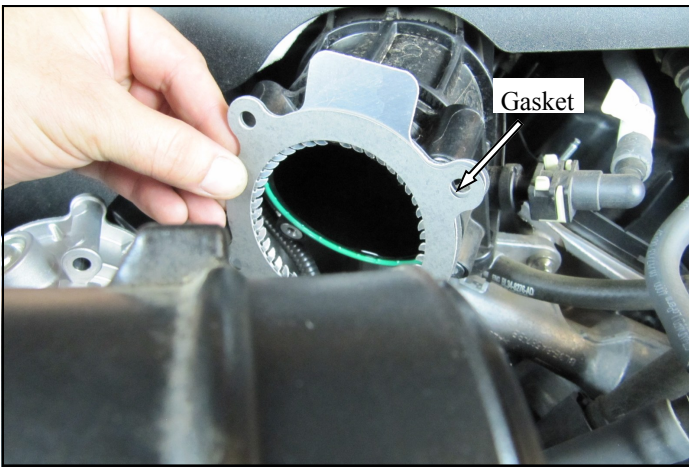

3. Pull the throttle body away from the intake manifold and Install the ECONOAID Throttle Booster and the supplied gasket. The logo is to be facing the throttle body and in the 12:00 o'clock position. the supplied gasket is to be on throttle body side. Align the bolt holes, and reinstall the factory bolts. Tighten the bolts to the factory specifications in an "X" pattern. Before starting the engine, manually cycle the throttle plate to make sure there are no obstructions.

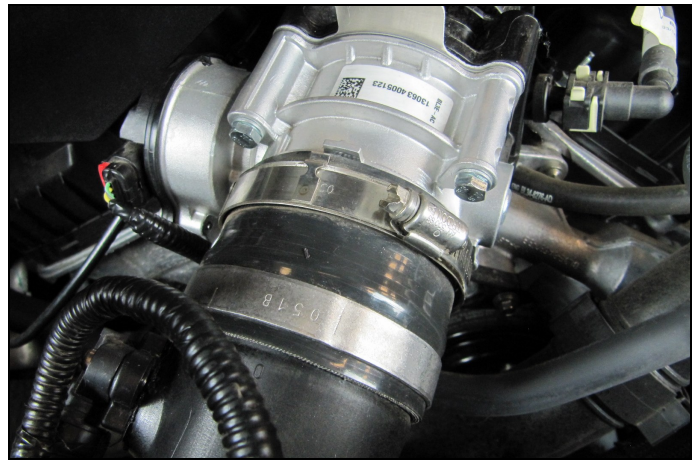

4. Slide the throttle body inlet tube back onto the throttle body and tighten the clamp.



5. Reinstall the intake tube, and any other parts that were removed to gain access to the throttlebody in the reverse order in which they were removed. Double check your work. Make sure there is no foreign material in the intake tract. Make sure all clamps, connectors, hoses, nuts, and bolts are secure.

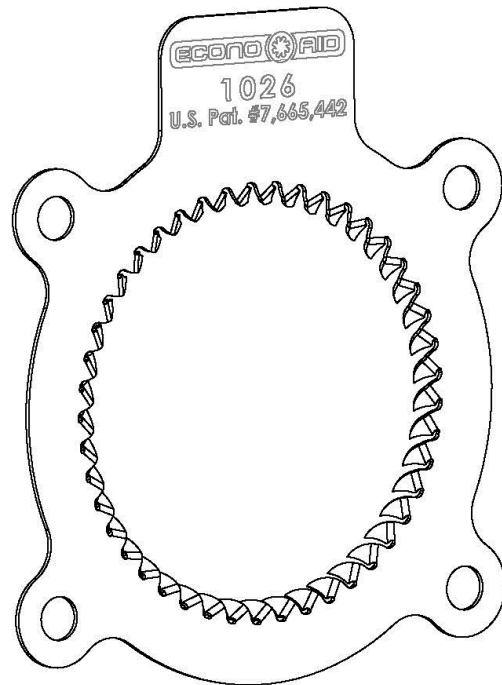

Instructions Revision
04.01.14