

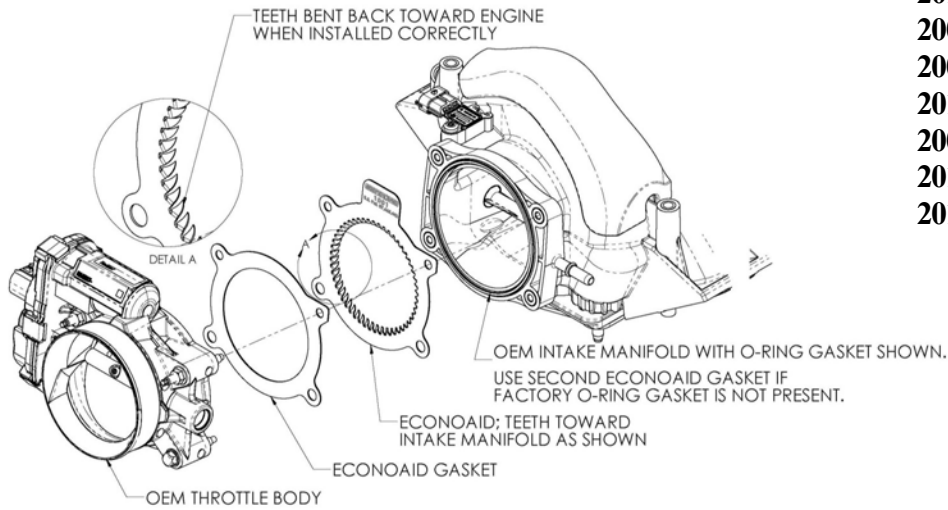

# Part Number 1027

- 2010-15 4Runner 4.0L
- 2010-14 FJ Cruiser 4.0L
- 2010-13 Sienna 3.5L
- 2007-14 Avalon 3.5L
- 2006-14 Camry 3.5L
- 2013-14 Camry 2.5 L Hybrid
- 2003-15 Venza 3.5L
- 2013 Rav4 3.5L
- 2013-15 Highlander 3.5L



### Tools Required For Installation

- 8mm, 10mm Sockets
- Ratchet and Extension
- Phillips Screwdriver

### Parts List

#1	ECONOAID	x1
#2	Gasket	x1

Thank you for purchasing the ECONOAID Throttlebody Booster. Please read the instruction manual carefully before proceeding with the installation. Contact ECONOAID @ (888) 876-4676 8:00 AM - 5:00 PM MST Weekdays for questions regarding fit or instructions that are not clear to you. Your ECONOAID Throttlebody Booster was carefully inspected and packaged. Check that no parts are missing, or were damaged during shipping. If any parts are missing, please contact ECONOAID.



U.S. Pat. #7,665,442

**These instructions depict an installation being performed on a FJ Cruiser and is meant to be a guide for all other makes and models listed. While specific details may vary from vehicle to vehicle, the general install procedure remains the same.**



**1.** Locate and loosen the intake tube clamps on both the throttlebody and the airbox. Remove the factory intake tube and set it aside. It may be necessary to remove the engine cover to gain access to the throttlebody on some applications.

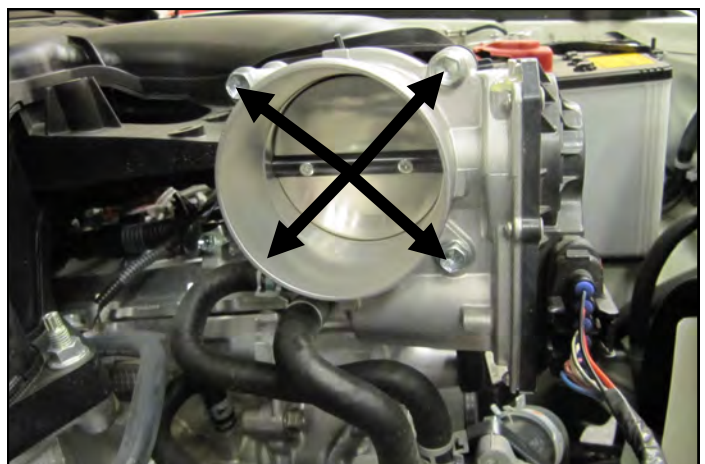

**3.** Remove the four bolts that secure the throttlebody to the intake manifold. It may also be necessary to remove a wiring bracket depending on your application.



4. Pull the throttlebody away from the intake manifold and Install the ECONOAID Throttle Booster and supplied gasket. The logo is to be facing the throttlebody and in the 12:00 o'clock position. the supplied gasket, is to be on the throttlebody side of the ECONOAID.



5. Align the bolt holes, and reinstall the factory bolts. Tighten the bolts to the factory specifications in an "X" pattern. Before starting the engine, manually cycle the throttle plate to make sure there are no obstructions.



5. Reinstall the intake tube, and any other parts that were removed to gain access to the throttlebody in the reverse order in which they were removed. Double check your work. Make sure there is no foreign material in the intake tract. Make sure all clamps, connectors, hoses, nuts, and bolts are secure.

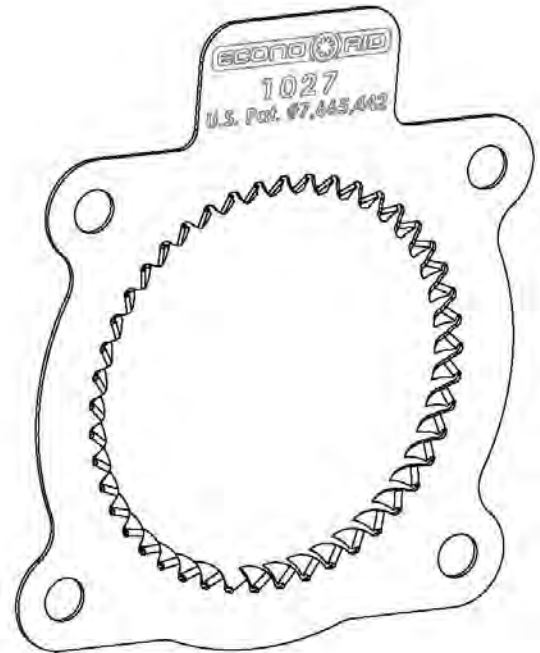

Instructions Revision  
10.08.14