

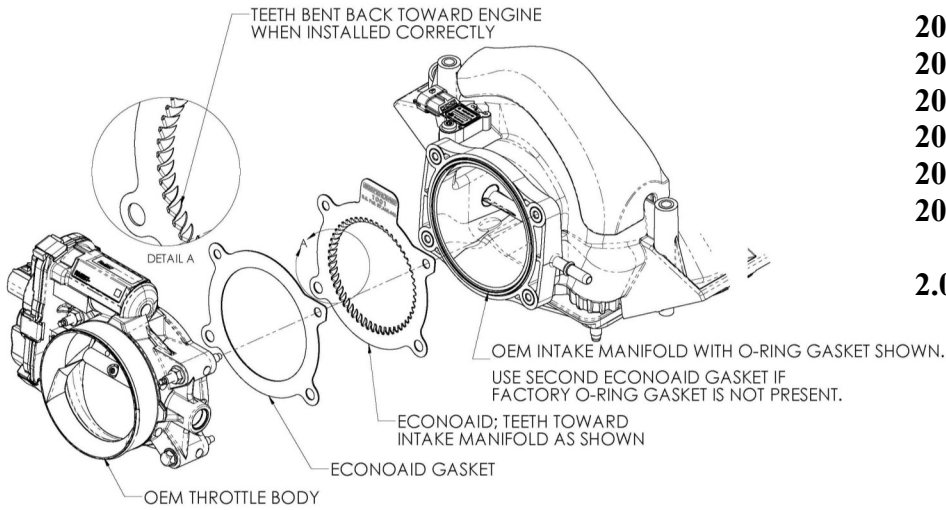

Part Number 1028



- 2006 - 2009 **HYUNDAI ELANTRA**
- 2006 - 2008 **HYUNDAI TIBURON**
- 2006 - 2009 **HYUNDAI TUCSON**
- 2006 - 2009 **KIA SPECTRA**
- 2006 - 2009 **KIA SPECTRA5**
- 2006 - 2009 **KIA SPORTAGE**

2.0L I4

<u>Parts List</u>		
#1	ECONOAID	x1
#2	Gaskets	x2

Thank you for purchasing the ECONOAID Throttlebody Booster. Please read the instruction manual carefully before proceeding with the installation. Contact ECONOAID @ (888) 876-4676 8:00 AM - 5:00 PM MST Weekdays for questions regarding fit or instructions that are not clear to you. Your ECONOAID Throttlebody Booster was carefully inspected and packaged. Check that no parts are missing, or were damaged during shipping. If any parts are missing, please contact ECONOAID.



U.S. Pat. #7,665,442

These instructions depict an installation being performed on a Hyundai Elantra and is meant to be a guide for all other makes and models listed. While specific details may vary from vehicle to vehicle, the general install procedure remains the same.



1. Locate and loosen the intake tube clamp on the throttle-body . It may be necessary to remove the engine cover to gain access to the throttlebody on some applications.



2. Unclip the air box lid, slide the intake tube off of the throttle body and lay it off to the side. Some models may have a breather attached to the intake tube. On these models, the breather will need to be disconnected as well.

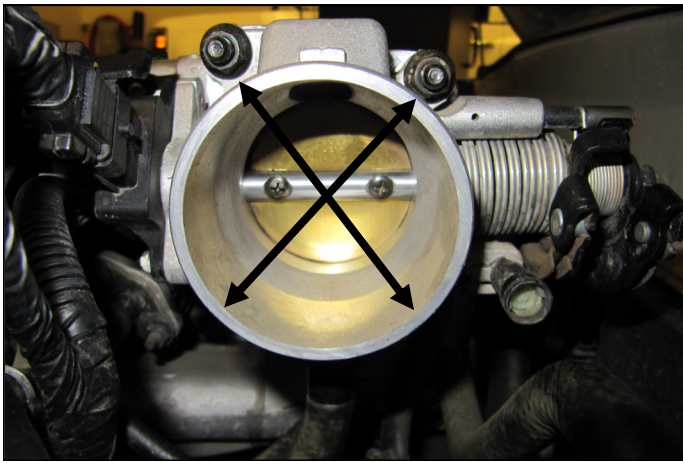

3. Remove the four nuts that secure the throttlebody to the intake manifold. It may also be necessary to remove a wiring bracket depending on your application.

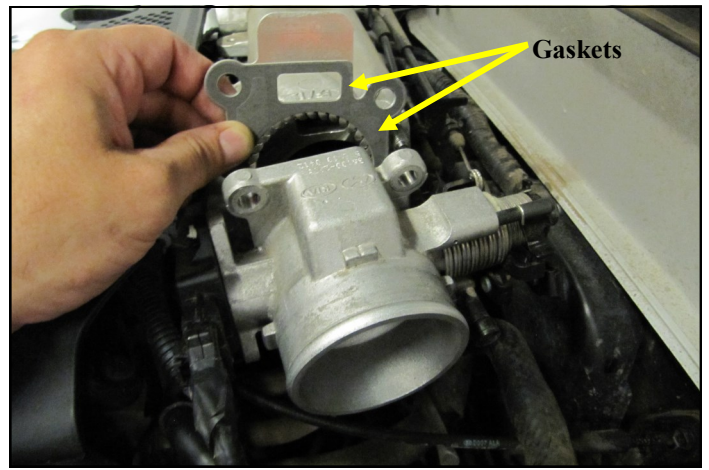

4. Pull the throttlebody away from the intake manifold and install the ECONOAID with the supplied gaskets. The logo should be facing the throttlebody. The supplied gaskets, are to be on the each side of the ECONOAID. Do not re use the factory gasket.



5. Reinstall the throttlebody. Tighten the nuts to the factory specifications in an "X" pattern. Before starting the engine, manually cycle the throttle plate to make sure there is no obstructions to movement.



6. Reinstall the intake tube and airbox lid, and any other parts that were removed to gain access to the throttlebody. Double check your work. Make sure there is no foreign material in the intake tract. Make sure all clamps, connectors, hoses, nuts, and bolts are secure.

Econoaid's come with a 123 day money back guarantee

If you decide at any time during the 123 day period that you are not happy with your Econoaid you can return it for a full refund

Original receipt of purchase is required for refund.
 *Refund amount does not include original shipping

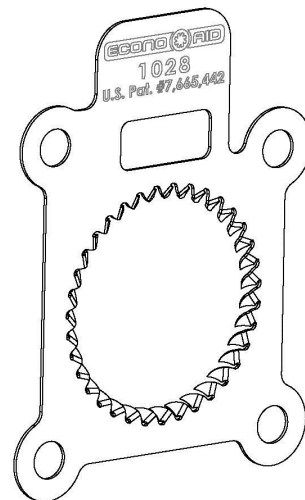

Instructions Revision
 07.22.13