

AIR AID[®]

INTAKE SYSTEMS

#200-129 INSTALLATION INSTRUCTIONS

03-04 Chevy Duramax / 01-04 GMC Duramax 6.6L

(Will NOT fit 01-02 Chevy, use Part #200-135)

***Please Note: This kit does not fit the 2004 "LLY" engine**

Thank you for purchasing the Airaid Intake System. Please read the instruction manual carefully before proceeding with the installation. Contact Airaid @ (800) 498-6951 8:00 AM - 5:00 PM MST weekdays for questions regarding fit or instructions that are not clear to you. Your Airaid Intake System was carefully inspected and packaged. Check that no parts are missing, or were damaged during shipping. If any parts are missing, contact Airaid. The air filter element is protected from direct exposure to water and debris; care should be taken not to drive through deep water. WATER INGESTION IS THE DRIVERS RESPONSIBILITY! The air filter is reusable and should be cleaned using the Airaid Filter Tune-Up Kit periodically.

Thank you for selecting Airaid.



Packing List:

| | | |
|---------------|------------------------|---|
| 700-469 | Airaid Premium Filter | 1 |
| KIT112MAFADA | Black MAF Adapter | 1 |
| KIT1121RRDAMC | Rear Air Dam Coated | 1 |
| KIT1121MAFC | MAF Panel Coated | 1 |
| KIT129T | Intake Tube | 1 |
| KITHUMPHS05 | Silicone Hump Hose | 1 |
| KITCOUPLER01 | Silicone Coupler Hose | 1 |
| KITWSTRIP02 | Weather Strip 19 1/2" | 1 |
| KIT129HP | Hardware Pack | 1 |
| - KIT10BHCP50 | 8/32 x 1/2" Allen Bolt | 2 |
| - KITHS60 | #60 Hose Clamp | 2 |
| - KITHS64 | #64 Hose Clamp | 2 |

Packing List (cont'd):

| | | |
|----------------|------------------------|---|
| - KIT6NWSAPZ | #6 Flat Washer | 5 |
| - KIT6CNKEPZ | 6-32 Keps Nut | 5 |
| - KIT6C31MXPPZ | 6-32 X 5/16" Screw | 5 |
| - KIT25C62HCSS | 1/4-20 x 5/8" Hex Bolt | 3 |
| - KIT09FWZ019 | 1/4" Flat Washer | 7 |
| - KIT60C250HCS | M6-1 x 25 Hex Bolt | 4 |
| - KIT10ANSSWAS | Steel Washer Spacers | 2 |
| - KITBIT#T20 | T-20 Security Bit | 1 |

Tools Required for this Installation:

Flat Head Screwdriver
10mm Socket or Wrench
3/32" Allen Wrench

Installation Instructions. Read Me!

I DISCONNECT NEGATIVE (-) BATTERY CABLE

II Remove Factory Intake Assembly

- a) Carefully disconnect and remove the mass air sensor using the supplied T-20 security bit (save for later use). **See Fig#1**
- b) Remove the filter minder and rubber grommet and save for re-installation. **See Fig#2**
- c) Loosen the two hose clamps on either end of the factory intake tube and remove the tube from the vehicle.
- d) Remove the factory air box: the air box “pops” out of place, simply pry it out of position and remove.
- e) Using a 10mm socket, remove the 5 bolts on the base of the factory air box and remove metal base from vehicle. **See Fig#3**

III Assemble the Airaid Intake System

- a) Assemble the Airaid Cold Air Dam using the 6 small screws, washers, and nuts provided. **See Fig#4**
- b) Install the black plastic filter adapter, secure using the three ¼-20 bolts provided. **See Fig#5**
- c) Slide the Airaid Premium Filter over the plastic adapter and tighten hose clamp. **See Fig#5**
- d) Press weather strip into place along the top rim of the air dam. **See Fig#4** (Hint: start in the corner for easy installation).

IV Install the Airaid Intake System

- a) Align the holes in the bottom the Airaid Cold Air Dam with the bolt holes that formerly secured the factory air box and bolt into place with the provided hardware. **Refer to Fig#6** for proper placement.
- b) Using hardware provided, install the factory mass air sensor into the Airaid intake tube before installing the tube. (Note: the two thick steel washers supplied must be placed between the mass air sensor and the tube). **See Fig#7** (Note: **refer to Fig#8** for correct mounting location of the mass air sensor.)
- c) Install factory rubber grommet into the hole in the Airaid intake tube and then mount the factory filter minder into the rubber grommet. **See Fig#9**
- d) Slide the silicone hump hose provided onto large end of the tube and secure with a #64 hose clamp, leave clamp loose for final adjustments. **See Fig#9**
- e) Install the silicone coupler on the other end of the tube and secure loosely with a #60 hose clamp. **See Fig#9**
- f) Slide tube with coupler over the factory turbo charger inlet and secure loosely with a #60 hose clamp. **See Fig#9**
- g) Align Airaid tube assembly to the black filter adapter on the cold air dam and position the hump hose over the black filter adapter, secure loosely using a #64 hose clamp. **See Fig#9**
- h) Re-connect the mass air sensor.

VI Finishing Up

- a) Make sure that the intake path is clear of all debris!
- b) Check alignment of the Airaid intake tube and tighten all clamps, brackets, nuts & bolts.
- c) Inspect overall work and check hood clearance.
- d) Re-connect negative battery cable.



References

FIG#1



FIG#2



FIG#3



FIG#4

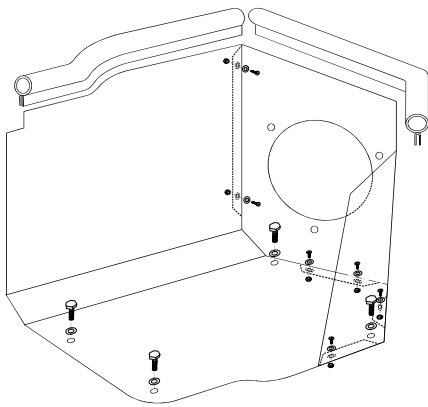

FIG#5

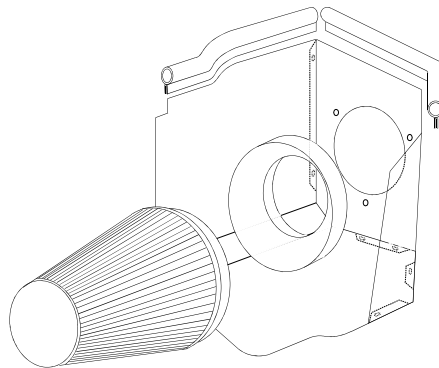

FIG#6

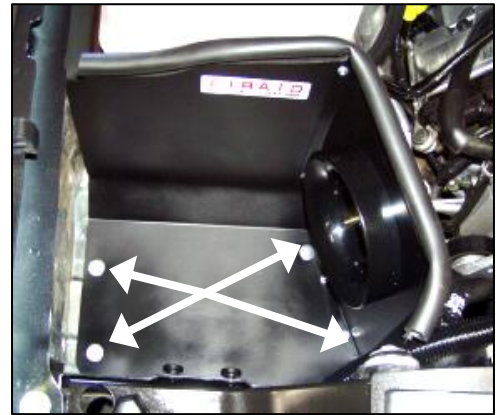

FIG#7

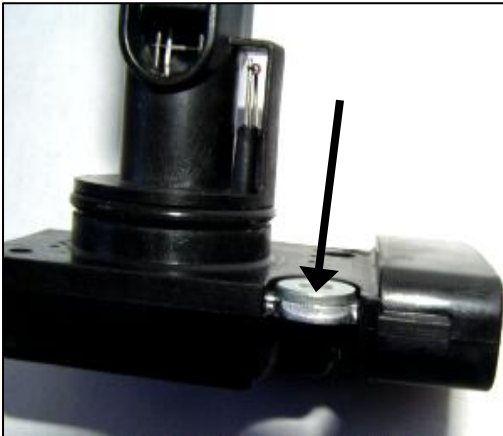

FIG#8



FIG#9

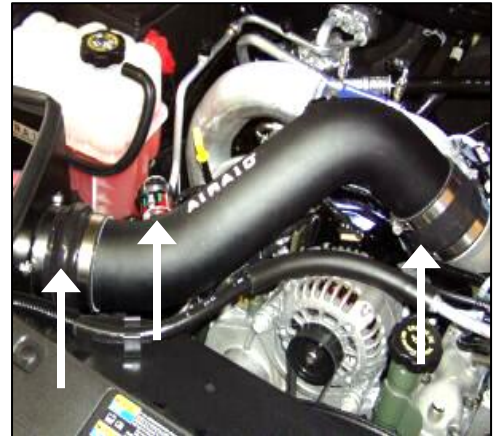

VEHICLE WARRANTY INFORMATION

AIRAID Intakes and Filters will NOT void your vehicle's warranty. The federal Magnuson-Moss Warranty Act of 1975 states that the manufacturer can't void a vehicle's warranty because an aftermarket part is used. This is called a tie-in sale. Which means a manufacturer can't require the use of a certain brand of product. The only exception to this is the condition they provide the product for free. For assistance or more information the Federal Trade Commission can be contacted at 1-877-FTC-HELP (1-877-382.4357).

Don't Forget Your AIRAID Filter Tune-Up Kit!

P/N 790-550



Instructions Revision
Date: 11/7/05

Before

After!

