

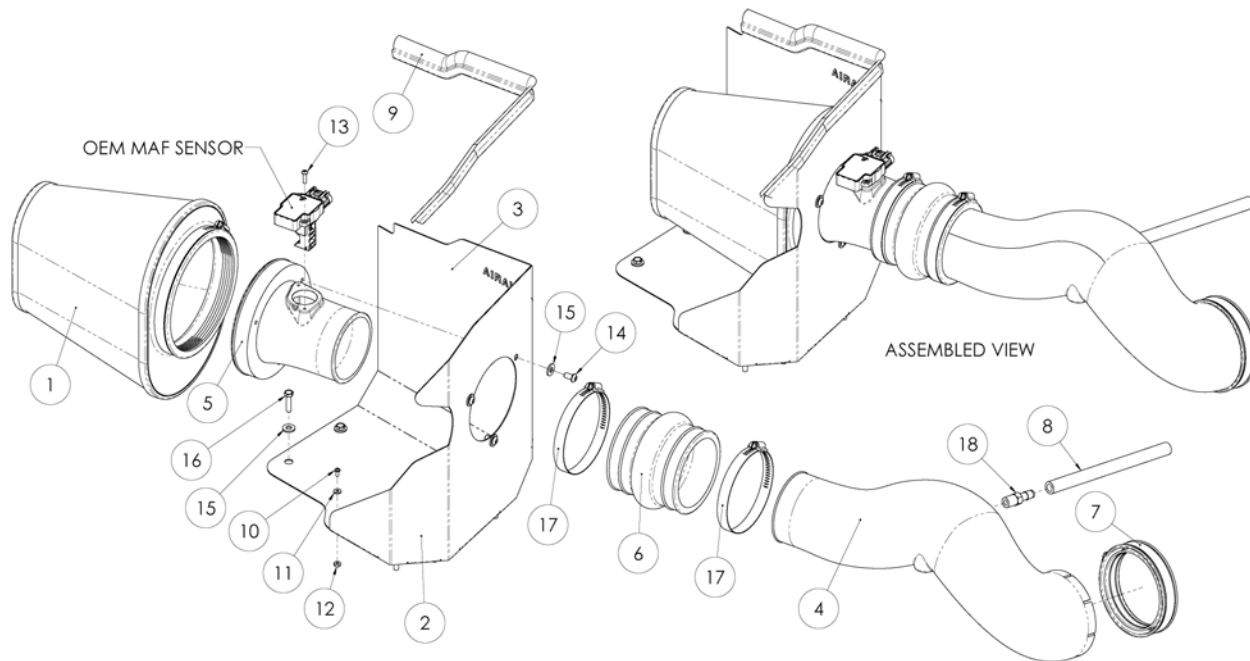

INTAKE SYSTEMS



Installation Instructions
Part Number 200-235
2009-2010 Chevrolet Silverado/Suburban
2500/3500
GMC Sierra/Yukon XL 2500/3500
6.0L V-8
With Mechanical Cooling Fan

Packing List:

#1	720-472	Airaid Premium Filter	1
#2	KIT233MAFDAC	MAF Panel	1
#3	KIT196RRDAMC	Rear Air Dam Panel	1
#4	KIT225T	Airaid Intake Tube	1
#5	KIT233A	Air Filter Adapter	1
#6	KITHUMPHS02	Urethane Hump Hose	1
#7	KITCOUPLER02	Coupler W/#68 Hose Cl.	1
#8	KITHOSE06	3/8" x 8" Breather Hose	1
#9	KITWSTRIP02	Weather Strip 20 3/4"	1
	KIT235HP	Hardware & Instructions	1
#10	KIT6C31MXPPZ	6-32 x 5/16" Screw	5
#11	KIT6NWSAPZ	#6 Flat Washer	5
#12	KIT6CNKEPZ	6-32 Keps Nut	5
#13	KIT15BHC63063	8-32 x 5/8" Button Head Bolt	2
#14	KIT15DHC3050	1/4 - 20 x 1/2" Button Head Bolt	3
#15	KIT09FWZ019	1/4" Flat Washer	7
#16	KIT60C250HCS	M6 - 1 x 25 Hex Bolt	4
#17	KITHS64	#64 Hose Clamp	2
#18	KITFITTING01	1/4" NPT x 3/8" Barb Fitting	1

Tools Required For Installation:

5/16", 10mm Sockets
 Ratchet & Extension
 Phillips Screwdriver
 3/32", 5/32" Allen Wrench
 T15 Torx Bit



1. Disconnect the negative battery cable.
 Remove the factory beauty cover by lifting up on the front, and then pulling the cover towards the front of the vehicle. It is only held in place by grommets.

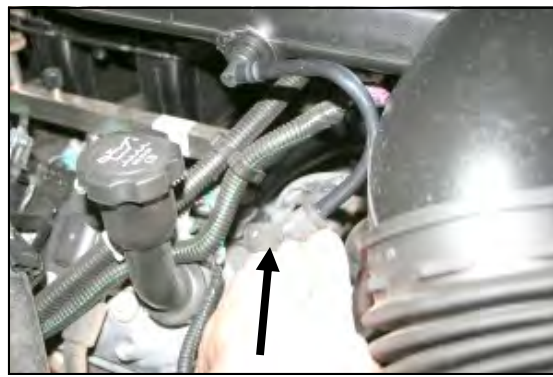

2. Disconnect the factory breather hose at the valve cover by pulling the small black tab on the fitting towards the front of the vehicle, and then to the right.



3. Separate the factory intake tube from the plastic clamp that secures the radiator hose to the tube. A firm downward push will usually do it.



4. Loosen two hose clamps on the factory intake tube. One at the throttlebody, and one where it clamps to the factory airbox. Remove the factory intake tube from the vehicle.



5. Remove, and set aside the MAF (Mass Air Flow) sensor from the factory airbox. This will require a T15 Torx Bit.



6. Rock the factory airbox back and forth to loosen it from the mounting grommets, and remove it from the vehicle.



7. Using a 10mm socket, remove four bolts, and then remove the factory airbox mounting plate from the vehicle.



8. Assemble the Cool Air Dam panels (CAD) (#2 & #3) using five 6-32 x 5/16" screws (#10), #6 flat washers (#11), and 6-32 keps nuts (#12). Next install the air filter adapter (#5) into the panels as shown with the hole for the Mass Air Flow sensor facing up, using three 1/4 - 20 x 1/2" button head bolts (#14), and 1/4" flat washers (#15).



9. Install the Airaid CAD assembly into the vehicle replacing the factory airbox. Secure the CAD using four M6 x 1.25 Hex Bolt (#16), and 1/4" flat washers (#15). Do not over tighten the four bolts.



10. Reinstall the MAF sensor onto the filter adapter using two 8-32 x 5/8" Allen Bolts (#13).

Do Not Use The Factory Screws!

Next install the urethane hump hose (#6) onto the MAF with the two #64 hose clamps (#17). Leave the clamps loose for now.



11. Install the 1/4" NPT x 3/8" Barb Fitting (#18) into the Airaid Intake Tube as shown. Next install the supplied coupler and hose clamp (#7) onto the throttle body end of the tube. Leave the clamp loose for now.



12. Install the Airaid Intake Tube into the hump hose first, and then onto the throttle body. Adjust it for fit, and then tighten all three hose clamps. Reinstall the plastic retainer on the radiator hose into the bottom of the Airaid Intake Tube. Refer to step #3.



13. Install the 3/8" x 8" breather hose (#8) between the 1/4" NPT x 3/8" barbed fitting in the tube, and the factory port on the valve cover.



14. Install the Airaid Premium Filter (#1) onto the air filter adapter, and tighten the hose clamp. Next install the provided weather strip (#9) onto the top of the CAD. For ease of install, start at the inner fender, and work your way towards the radiator. Reinstall the beauty cover.

15. Double check your work!

Make sure there is no foreign material in the intake path. Make sure all clamps, hoses, bolts, and screws are tight.

16. Reconnect the negative battery cable!

Thank you for purchasing the Airaid Intake System. Contact Airaid @ (800) 498-6951 8:00 AM - 5:00 PM MST weekdays for questions regarding fit or instructions that are not clear to you. Your Airaid Intake System was carefully inspected and packaged. Check that no parts are missing, or were damaged during shipping. If any parts are missing, contact Airaid. The air filter element is protected from direct exposure to water and debris; care should be taken not to drive through deep water. WATER INGESTION IS THE DRIVERS RESPONSIBILITY! The air filter is reusable and should be cleaned using the Airaid Filter Tune-Up Kit periodically.

Before!



After!



Don't Forget Your AIRAID Filter Tune-Up Kit!



P/N 790-551 Aerosol Spray
P/N 790-550 Squeeze Spray



Instructions Revision
Date: 07/27/10