

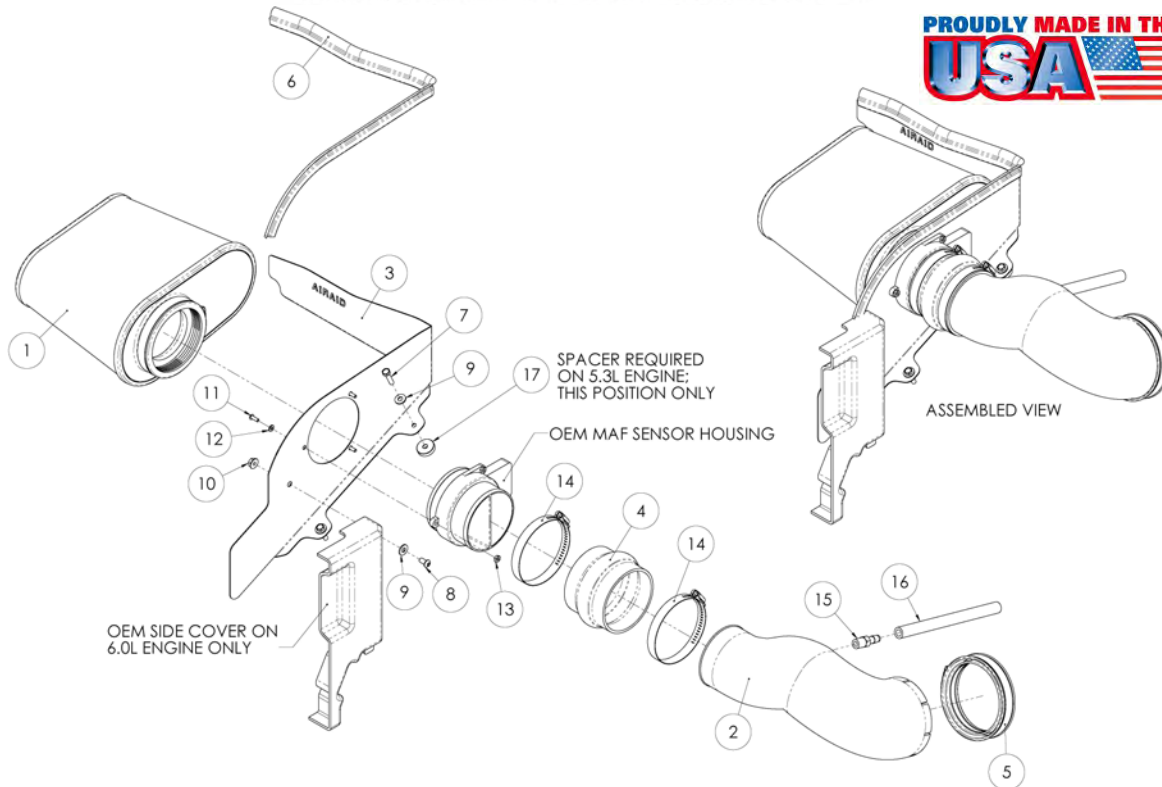

## INTAKE SYSTEMS



**Installation Instructions**  
**Part Number 201-206-1**  
**2005-08 Chevrolet Trailblazer 5.3L**  
**2005-09 Chevrolet SS Trailblazer 6.0L**  
**2005-09 GMC Envoy 5.3L**

### Packing List:

#1	721-477	Airaid Premium Filter	1
#2	KIT2061T	Airaid Intake Tube	1
#3	KIT206MAFC	MAF Panel	1
#4	KITHUMPHS18	Silicone Hump Hose	1
#5	KITCOUPLER02	CouplerW/#68 Clamp	1
#6	KITWSTRIP02	Weather Strip 26"	1
	KIT2061HPS	Hardware & Instructions	1
#7	KIT60C250HCS	M6 x 25mm Hex Bolt	3
#8	KIT15DHC3050	¼ - 20 x 1/2" Button Head Bolt	1
#9	KIT09FWZ019	¼" Flat Washer	4
#10	KIT1420WZZF	¼ - 20 Serrated Nut	1
#11	KIT15BHC3050	8-32 x 1/2" Button Head Screw	3
#12	KIT15FW3016	#8 Flat Washer	3
#13	KIT8CNKEPZ	8-32 Keps Nut	3
#14	KITHS56	#56 Hose Clamp	2
#15	KITFITTING01	¼" NPT x 3/8" Barbed Fitting	1
#16	KITHOSE06	3/8" x 8" Breather Hose	1
#17	KIT114B	Aluminum Spacer	1

### Tools Required For Installation:

Phillips & Flat Blade Screwdriver  
 T30 Torx Bit  
 7/16", 11/32", 9/16" Wrench  
 5/32", 3/32" Allen Wrench  
 5/16", 10mm Sockets  
 Ratchet and Extension



#### 1. Disconnect the negative battery cable.

**6.0 Liter Only:** Using a T-30 torx bit, remove the factory screw and engine beauty cover, and then set them aside for reuse.



2. Using a 5/16" socket or flat blade screwdriver, loosen the hose clamps on both ends of the factory intake tube.

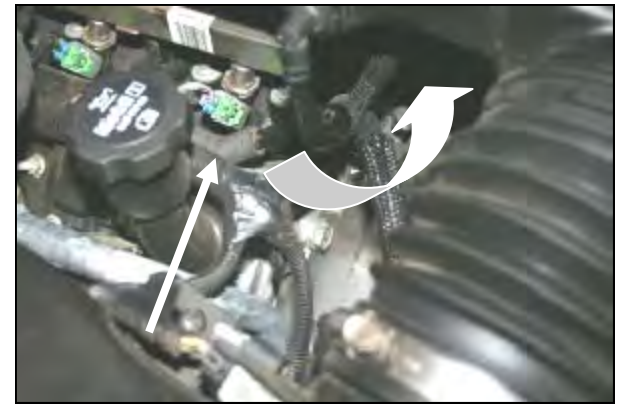

3. Slide the factory breather hose off of the metal tube on the engine.



4. Loosen the clamp holding the Mass Air Flow (MAF) sensor to the factory airbox lid. Remove the complete factory intake and breather tube. Remove the MAF sensor from the lid (do not disconnect it), and then set it aside.



5. **6.0 Liter Only:** Using a flat blade screwdriver, gently pry the plastic retaining clip from the oem side cover.

**All Models:** Loosen the four mounting screws on the factory airbox lid. Remove the factory airbox lid, filter, and resonator as an assembly.

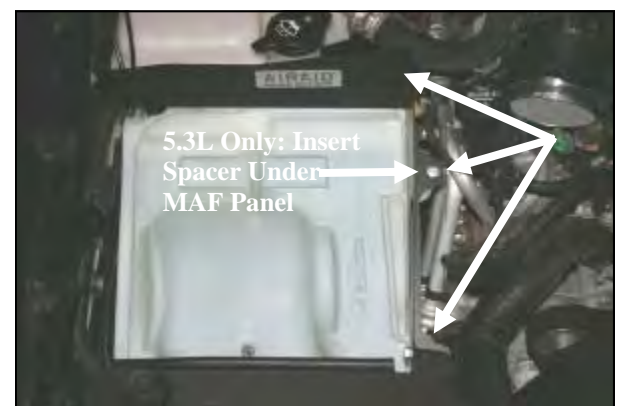

6. Mount the MAF Panel (#3) onto the airbox base using three M6 x 25mm Hex Bolts (#7), and ¼" flat washers (#9).

**5.3 Liter Only:** Insert one aluminum spacer (#17) between the panel and the lower airbox in the position as shown. Tighten using a 10mm socket, ratchet and extension.

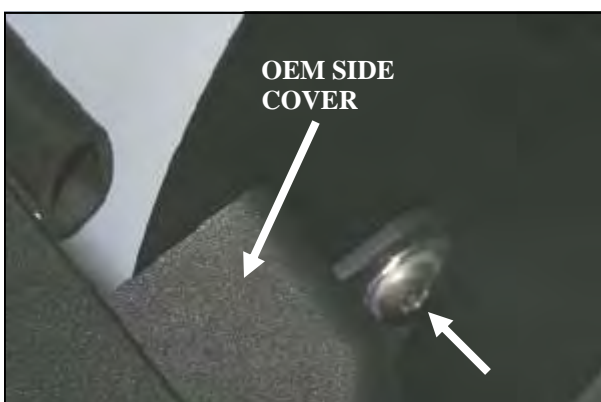

7. **6.0 Liter Only:** Insert one ¼ - 20 x 1/2" button head bolt (#8) and 1/4" flat washer (#9) through the hole in the oem side cover, and through the hole in the panel. Secure using one ¼ - 20 serrated nut (#10).

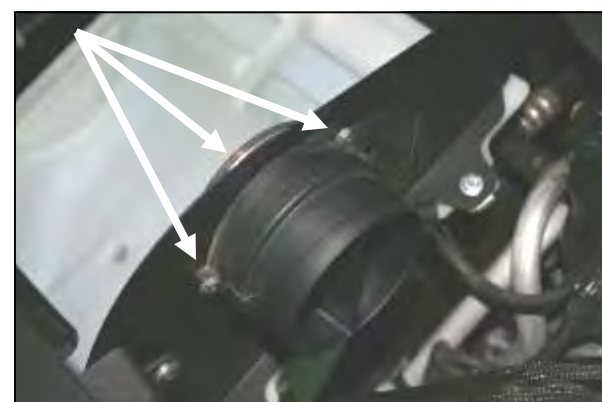

8. Mount the MAF sensor onto the panel using three 8-32 x 1/2" button head screws (#11), #8 flat washers (#12), and 8-32 keps nuts (#13). (Note: sensor should be mounted with "flow" arrow on top).



9. Slide the silicone hump hose (#4), and two #56 hose clamps (#14) onto the MAF sensor. Slide the coupler (#5) and one #68 hose clamp onto the throttle body. Tighten only the clamp on the MAF sensor for now.

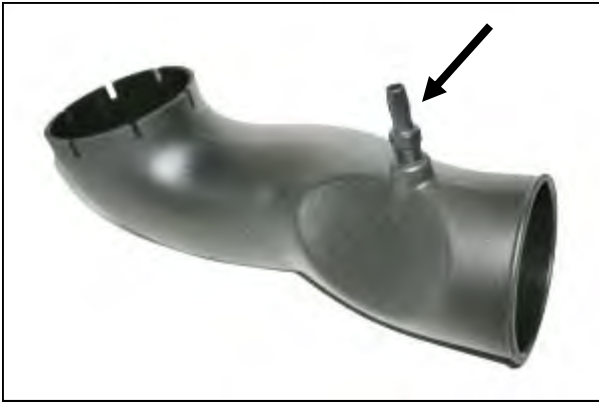

**10.** Insert one 1/4" NPT x 3/8" barbed fitting (#15) into the Airaid Intake Tube (#2).



**11.** Insert the Airaid Intake Tube (#2) into the hump hose first. Then, insert the throttle body end of the tube into the coupler. Adjust for fit, and tighten the clamps.

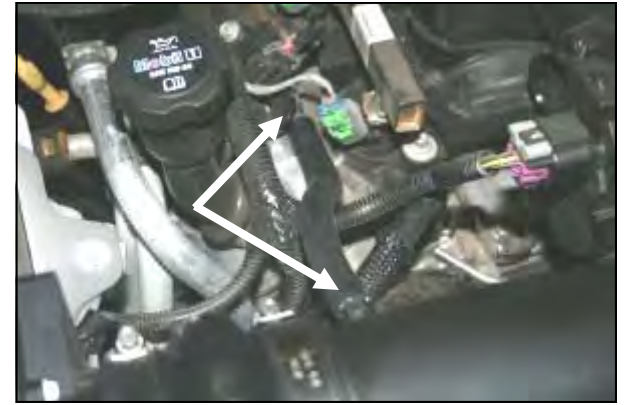

**12.** Slide one end of the 3/8" x 8" breather hose (#16) over the barbed fitting in the Airaid Intake tube. Slide the other end of the breather hose onto the metal tube on the engine.



**13.** Install the Airaid Premium Filter (#1) onto the MAF sensor. Rotate the filter so that the tab contacts the air box base, and then tighten the clamp. Install the weather strip (#6) onto the top of the panel. (*Hint: Start at one end and work towards the other.*)

**14. Double check your work!**

Make sure there is no foreign material in the intake path. Make sure all clamps, hoses, bolts, and screws are tight.

**15. Reconnect the negative battery cable!**

***Before!***

***After!***



***SynthaMax***

**Do Not Oil**

**Synthamax Air Filters do not require oil.** Service air filter as needed by cleaning with common non-petroleum all-purpose household cleaner and water. Simple Green®, Formula 409® or equivalent works great. Apply cleaner to outside of air filter and allow to soak. Then flush filter clean from the inside out with a garden hose and repeat steps if necessary. Do not apply high pressure water or air to clean filter. Allow filter to air dry and reinstall.



Instructions Revision  
Date: 10/25/10

Thank you for purchasing the Airaid Intake System. Contact Airaid @ (800) 498-6951 8:00 AM - 5:00 PM MST weekdays for questions regarding fit or instructions that are not clear to you. Your Airaid Intake System was carefully inspected and packaged. Check that no parts are missing, or were damaged during shipping. If any parts are missing, contact Airaid. The air filter element is protected from direct exposure to water and debris; care should be taken not to drive through deep water. WATER INGESTION IS THE DRIVERS RESPONSIBILITY!