

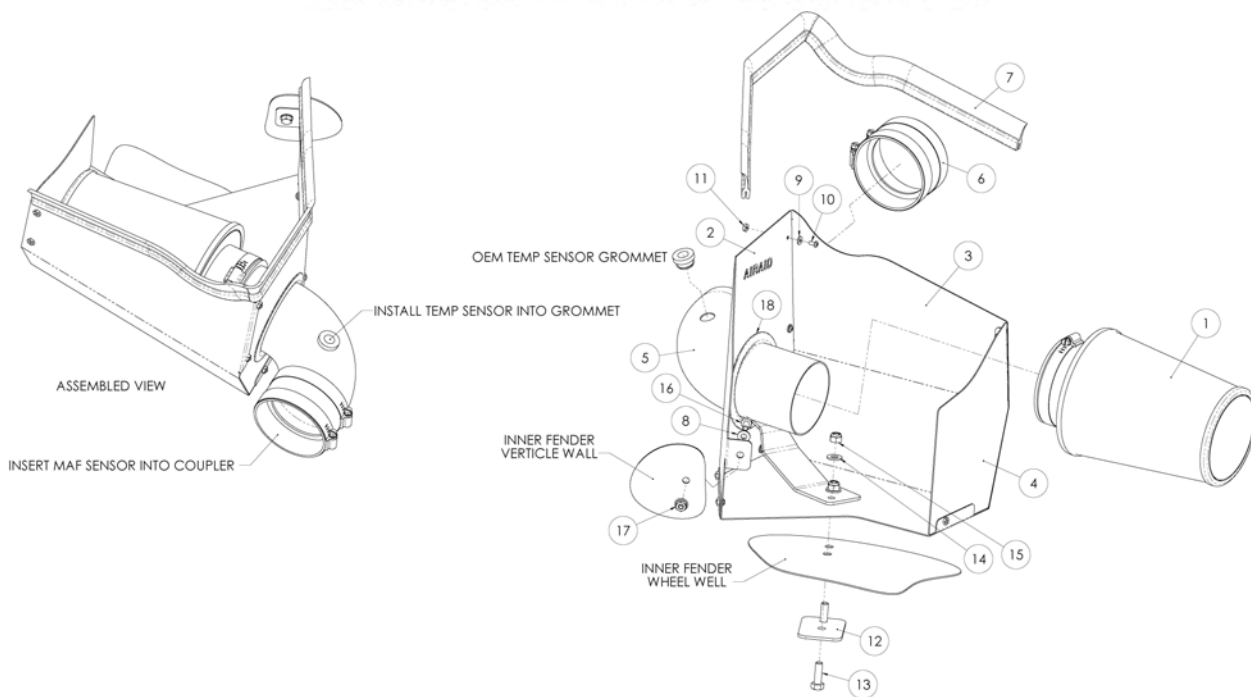

## INTAKE SYSTEMS



### Installation Instructions Part Number 201-207 1996-2000 GM Full Size Trucks & SUVs 4.3L, 5.0L, 5.7L Vortec Engines

#### Packing List:

#1	701-422	Airaid Premium Filter	1
#2	KIT102MAFC	MAF Panel	1
#3	KIT102BPC	Bottom Panel	1
#4	KIT102EPC	End Panel	1
#5	KIT102TAC	Airaid Intake Tube	1
#6	KITP300	Stainless Steel Coupler	1
#7	KITWSTRIP02	Weather Strip 25 1/4"	1
	KIT207HPS	Hardware & Instructions	1
#8	KIT09FWZ019	1/4" Flat Washer	1
#9	KIT6NWSAPZ	#6 Flat Washer	9
#10	KIT6C31MXPPZ	6-32 x 5/16" Phillips Screw	9
#11	KIT6CNKEPZ	6-32 Keps Nut	9
#12	KIT102P	3"x 2" Plate	1
#13	KIT31C100HCS5	5/16-18 x 1" Hex Bolt	2
#14	KIT25NWUSPZ	5/16" Flat Washer	2
#15	KIT31CNNEPZ	5/16" Nylock Nut	2
#16	KIT25C50HCSS	1/4-20 x 1/2" Hex Bolt	1
#17	KIT1420WZZF	1/4-20 Serrated Nut	1
#18	KITX1011	Rubber Trim 12 1/2"	1

#### Tools Required For Installation:

5/16", 7/16", 1/2" Sockets  
Ratchet & Extension  
7/16", 1/2" Wrenches  
Phillips Screwdriver

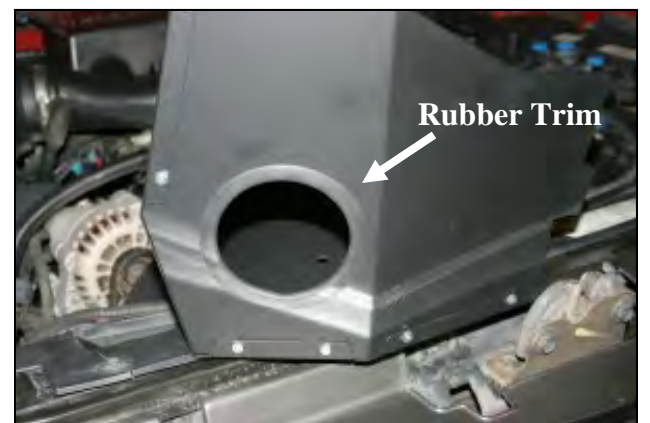
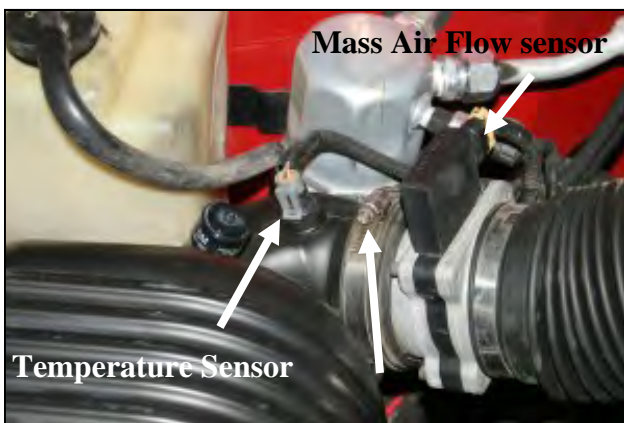

1. **Disconnect the negative battery cable.**  
**VERY CAREFULLY!** Remove the air intake temperature sensor first, and then the grommet from the air intake tube and set them aside. *There is no need to disconnect the wiring harness on the temp sensor.* Loosen the hose clamp that secures the air intake tube to the **Mass Air Flow (MAF)** sensor. Disconnect the **MAF** sensor from the intake tube and then remove the airbox from the vehicle.

2. Assemble the three **Cold Air Dam (CAD)** panels (#2, #3, & #4) as shown using nine 6-32 screws (#10), nine #6 washers (#9), and nine nuts (#11).

3. Install the supplied rubber trim (#18) into the hole in the **MAF Panel** (#2) as shown.



4. Insert the Airaid intake tube (#5) thru the hole in the **MAF** panel and then rotate it clockwise so that the holes in the bracket on the tube line up with the two holes in the bottom panel.

5. Install the stainless steel coupler (#6) onto the Airaid intake tube and tighten *only* the hose clamp on the tube.

6. Install the **CAD/Tube** assembly into the vehicle as shown using two 5/16"x 1" bolts (#13) thru the 3" x 2" plate (#12) up thru the fender well, thru the **CAD**, and thru the bracket on the intake tube, secured with two 5/16" flat washers (#14) and two 5/16" nylock nuts (#15). Next secure the **CAD** to the side fender well using one 1/4" hex bolt (#16), 1/4" flat washer (#8), and 1/4" serrated nut (#17). Refer to the line drawing above if needed.

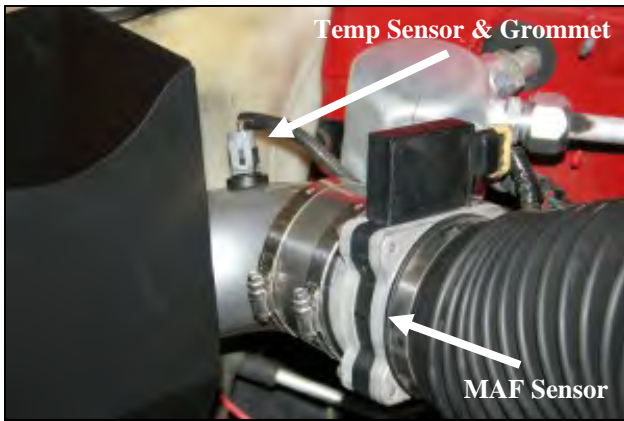

7. Connect the MAF sensor to the stainless steel coupler and tighten the hose clamp. Install the factory grommet removed in step #1, into the hole in the Airaid intake tube. **VERY CAREFULLY** install the factory temperature sensor into the grommet.



8. Install the Airaid Premium Filter (#1) onto the Airaid intake tube as shown, and then tighten the hose clamp. Next, install the weather strip on top of the CAD, starting at the right fender working your way towards the front of the vehicle.

**9. Double check your work!**

Make sure there is no foreign material in the intake path. Make sure all clamps, hoses, bolts, connectors, and screws are tight.

**10. Reconnect the negative battery cable!**

\* Note: Some '98's have been equipped with AIR (smog) pumps. If you have a 1" hose remaining after the install, then you have this pump and will require an additional breather K&N Part # 62-1040.

**Before!**



**After!**



*SynthaMax*®

**Do Not Oil**

Synthamax Air Filters do not require oil. Service air filter as needed by cleaning with common non-petroleum all-purpose household cleaner and water. Simple Green®, Formula 409® or equivalent works great. Apply cleaner to outside of air filter and allow to soak. Then flush filter clean from the inside out with a garden hose and repeat steps if necessary. Do not apply high pressure water or air to clean filter. Allow filter to air dry and reinstall.



Thank you for purchasing the Airaid Intake System. Contact Airaid @ (800) 498-6951 8:00 AM - 5:00 PM MST weekdays for questions regarding fit or instructions that are not clear to you. Your Airaid Intake System was carefully inspected and packaged. Check that no parts are missing, or were damaged during shipping. If any parts are missing, contact Airaid. The air filter element is protected from direct exposure to water and debris; care should be taken not to drive through deep water. WATER INGESTION IS THE DRIVERS RESPONSIBILITY!

Instructions Revision  
Date: 10/25/10