

# AIR AID®

## INTAKE SYSTEMS

**Installation Instructions**  
**Part Number 401-118**  
**1997- 04 Expedition 4.6, 5.4L**  
**1997- 03 F-150 4.6, 5.4L**  
**2004 F-150 4.6, 5.4L ‘Heritage’ (16 valve)**  
**\*Silver Tube**

### Packing List:

#1	701-420	Airaid Premium Filter	1
#2	KIT118TAC	Airaid Intake Tube	1
#3	KIT109A	MAF Bracket	1
#4	KIT109H35	Urethane Hump Hose	1
#5	KIT109H300	Urethane Reducer Hose	1
#6	KIT109H18	5/8" x 18" Breather Hose	1
#7	KIT109H9816	3/4" x 12" L-Hose	1
	KIT109HPS	Hardware & Instructions	1
#8	KIT25C87HCSS	1/4- 20x 7/8" Hex Bolts	6
#9	KIT09FWZ019	1/4" Flat Washer	4
#10	KIT25CNNES	1/4- 20" Nylock Nuts	6
#11	KIT109GAS	MAF Gasket	1
#12	KIT109B	MAF Backing Plate	1
#13	KITHS60	#60 Hose Clamp	3
#14	KITHS52	#52 Hose Clamp	1
#15	KITGRMT04	7/16" Rubber Grommet	1
#16	KITSNP19M4	Black Speed Clamp	2
#17	KITSNP22M4	Black Speed Clamp	2

### Tools Required For Installation:

Ratchet & Extension  
 10mm & 11mm Socket  
 7/16" Deep Socket  
 7/16" wrench  
 5/16" Socket or Nut Driver  
 Flat Blade Screwdriver  
 Pliers & Shop Knife

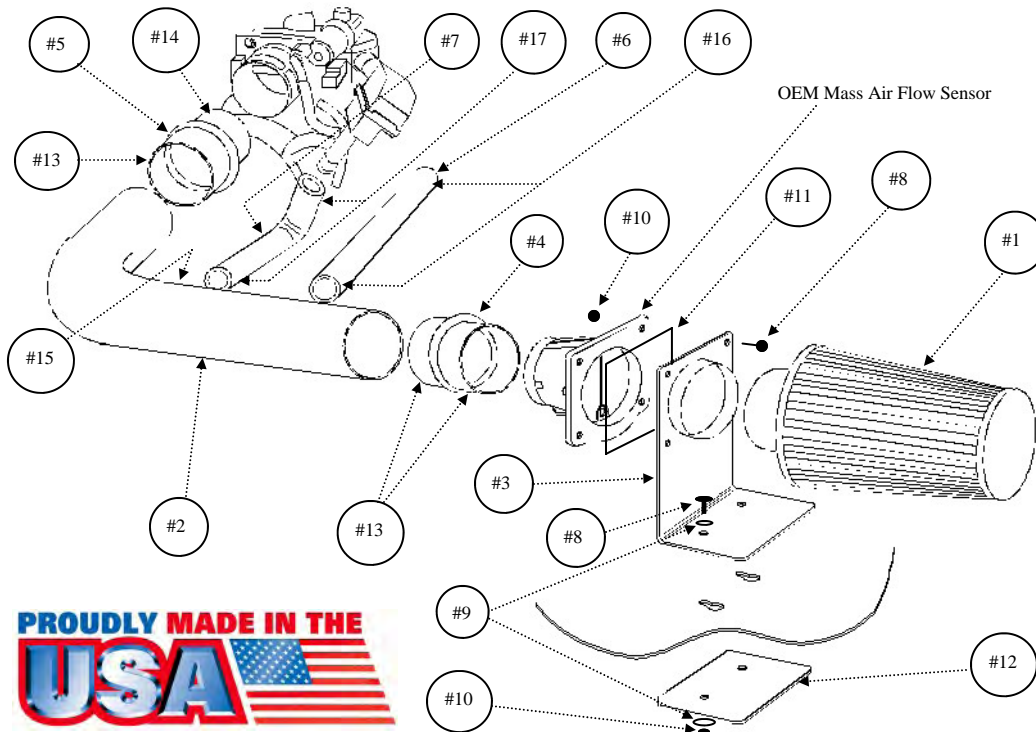

#### 1. Disconnect the negative battery cable.

Using a 10mm socket, remove the three bolts securing the engine beauty cover, remove the cover, and set it aside (save the bolts and cover for reuse).



2. Loosen the hose clamps at the throttle body, and air filter housing outlet.



3. Remove the crankcase breather hose from the factory intake tube and the valve cover. Disconnect the Air Intake Temperature (AIT) sensor wiring harness from the sensor. (4.6L Engine only: Disconnect the Idle Air Bypass Valve (IABV) inlet tube from the factory intake tube.) (5.4L Engine only: disconnect the IABV, save the plastic hose for reuse.)



4.) Remove the factory intake tube, and set it aside. Remove the AIT sensor from the tube by carefully prying it out with a flat blade screwdriver (save the sensor for reuse). Disconnect the Mass Air Flow (MAF) sensor wiring harness from the main engine wiring harness.



5. The factory airbox assembly is held in place by rubber grommets (it is a "pull to release fit."). Remove the assembly and grommets from the engine compartment. Unlatch the airbox and separate the two sections. Remove the wire loom from the MAF sensor wiring harness, then slide the grommet away from the connector.



6. Locate the notch on the flat side of the airbox and gently pry it up. Disconnect the MAF sensor wiring harness from the sensor (inside the airbox).

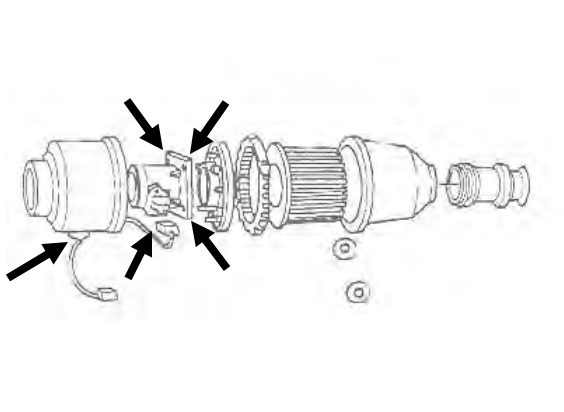

7. Using a 10mm socket, remove the four MAF sensor mounting nuts. Carefully remove the MAF sensor and the wiring harness from the airbox, (save them for reuse).

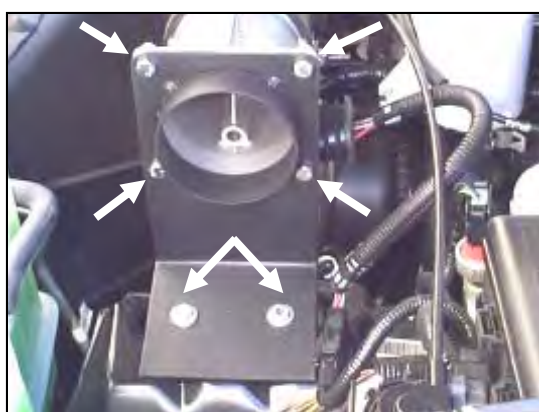

8. Mount the MAF sensor to the MAF bracket (#3) using four 1/4-20x 7/8" hex bolts (#8), 1/4-20" nylock nuts (#10), and the MAF gasket (#11). Mount the bracket and sensor to the factory location, using the MAF backing plate (#12), two 1/4-20x 7/8" hex bolts (#8), four 1/4" flat washers (#9), and two 1/4- 20" nylock nuts (#10). (Leave the MAF bracket loose for now).

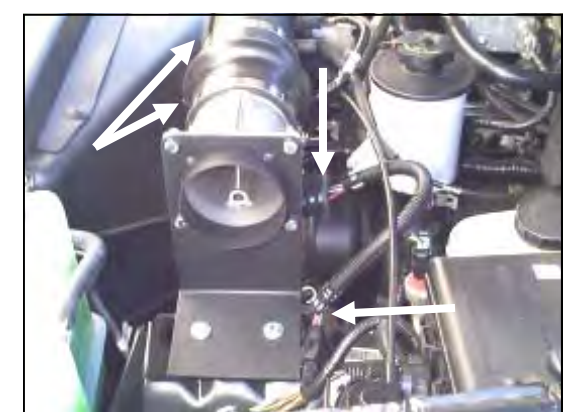

9. Reconnect the MAF sensor wiring harness to the sensor, and to the main engine wiring harness. Install the urethane hump hose (#4) onto the MAF sensor, with two #60 hose clamps (#13). Tighten only the clamp on the sensor.

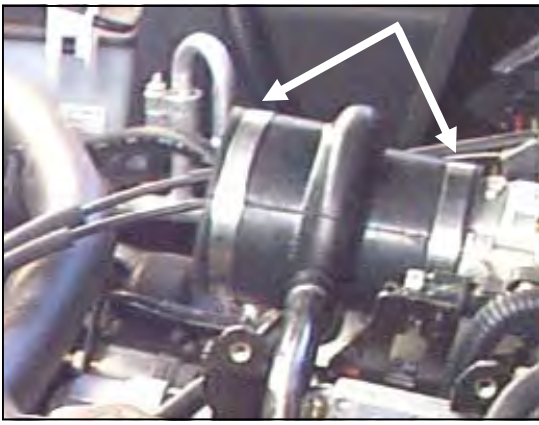

**10.** Install the small side of the urethane reducer hose (#5) onto the throttle body using one #52 hose clamp (#14). Install one #60 hose clamp (#13) onto the larger side of the reducer hose. Tighten only the clamp on the throttle body.

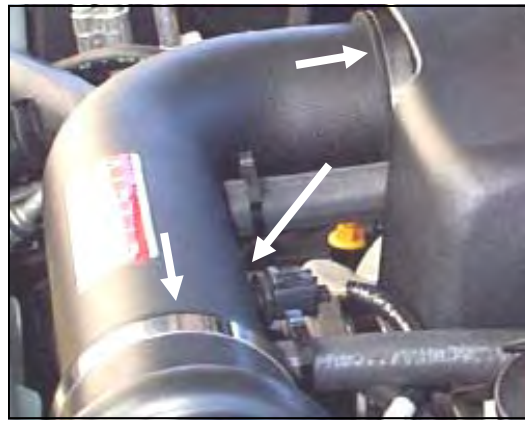

**11.** Install the 7/16" rubber grommet (#15) into the Airaid Intake Tube (#2). Insert the factory AIT sensor into the grommet. Slip the Airaid Intake Tube into the urethane hump and reducer hoses. Align for best fit and tighten the remaining hose clamps. Tighten the MAF bracket and reconnect the AIT sensor wiring harness.



**12.** Install the 5/8"X18" breather hose (#6) onto the valve cover breather fitting then onto the Airaid Intake Tube nipple. Secure the hose using two #19 speed clamps (#16).

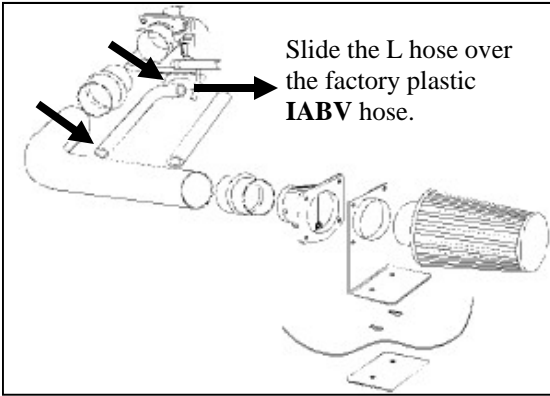

Slide the L hose over the factory plastic IABV hose.

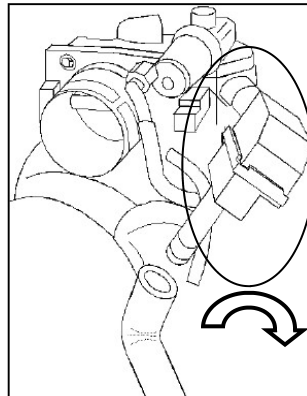

**14. 4.6L engines:** Rotate the IABV inlet tube 90 degrees to provide clearance for the 3/4 x 12" L-hose (#7).

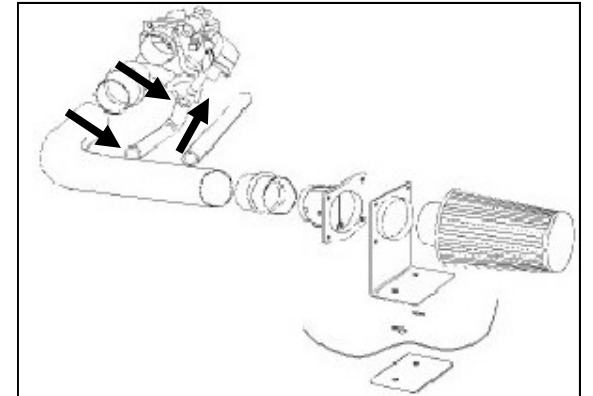

**15. 4.6L engines continued:** Connect the Airaid Intake Tube nipple to the IABV inlet tube using the 3/4 x 1/2" L-hose (#7), and two #22 speed clamps (#17).

**13. 5.4L engines:** Measure and cut the 3/4 x 12" L-hose (#7) as needed, then slide it over the factory plastic IABV hose. Install the hose onto the Airaid Intake Tube nipple and secure it using two #22 speed clamps (#17).

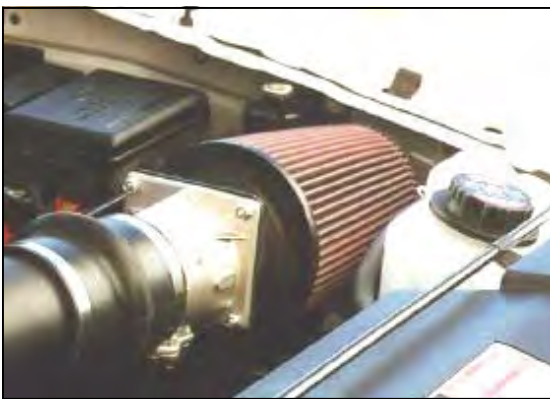

**16.** Install the Airaid Premium Filter (#1) onto the MAF bracket, and tighten the clamp. Reinstall the beauty cover using the three factory bolts.

**17. Double check your work!**

Make sure there is no foreign material in the intake path. Make sure all clamps, hoses, bolts, and screws are tight.

**18. Reconnect the negative battery cable!**

**Before!**



**After!**



Thank you for purchasing the Airaid Intake System. Contact Airaid @ (800) 498-6951 8:00 AM - 5:00 PM MST weekdays for questions regarding fit or instructions that are not clear to you. Your Airaid Intake System was carefully inspected and packaged. Check that no parts are missing, or were damaged during shipping. If any parts are missing, contact Airaid. The air filter element is protected from direct exposure to water and debris; care should be taken not to drive through deep water. WATER INGESTION IS THE DRIVERS RESPONSIBILITY!

**SynthaMax**

**Do Not Oil**



Synthamax Air Filters **do not** require oil. Service air filter as needed by cleaning with common non-petroleum all-purpose household cleaner and water. Simple Green®, Formula 409® or equivalent works great. Apply cleaner to outside of air filter and allow to soak. Then flush filter clean from the inside out with a garden hose and repeat steps if necessary. Do not apply high pressure water or air to clean filter. Allow filter to air dry and re-install.