

AIR RAID[®]

INTAKE SYSTEMS

521-130 INSTALLATION INSTRUCTIONS

00-04 Nissan Frontier/Xterra 3.3L

Thank you for purchasing the **AIR RAID Intake System**. Please read the instruction manual carefully before proceeding with the installation. Contact **AIR RAID** (800-498-6951) 8:00 AM - 5:00 PM MST weekdays) for questions regarding fit or instructions that are not clear to you. Your **AIR RAID Intake System** was carefully inspected and packaged. Check that no parts are missing, or were damaged during shipping. If any parts are missing, please contact **AIR RAID**. The air filter element is protected from direct exposure to water and debris in its new location. Care should be taken not to drive through deep water. **WATER INGESTION IS THE DRIVERS RESPONSIBILITY!** The conical air filter is washable oiled cotton gauze. It is a lifetime element. A cleaner kit is offered for servicing the air filter element.

Thank you for selecting AIR RAID.



Packing List

721-130	Airaid Premium Filter	1
KIT130RRC	Rear Dam	1
KIT130MAFC	Top Dam	1
KITWSTRIP02	Weather Strip	1
KIT130TFC	Adapter Tube	1
KIT130HPS	HARDWARE PACK	1
Instruction Sheet		x1
KIT130G	Gasket	x1
KIT130L	Dam Extension	x1
KIT130FILTER	PCV Line Filter	x1
KIT6C31MXPPZ	6-32x5/16 Screw	x5
KIT6CNKEPZ	6-32 Keps Nut	x5
KIT6NWSAPZ	#6 Flat Washer	x5
KIT25C87HCSS	1/4-20x7/8 Hex Bolt	x4
KIT09FWZ019	3/16 USS Washer	x8
KIT25CNNES	1/4-20 Lock Nuts	x4

Tools Required for Installation

Ratchet Wrench
10mm Socket
5/16" Socket or Nut Driver
1/2" Socket
1/2" Wrench
6" Socket Extension
Flat Blade Screwdriver
Pliers

Installation Instructions. Read Me!

- 1) DISCONNECT NEGATIVE (-) BATTERY CABLE.
- 2) Remove air box top lid.
 - a) Loosen hose clamp at Mass Air Flow (M.A.F.) meter and airbox lid. See FIG. #1
 - b) Disconnect MAF sensor wire.
 - c) Unclip air box lid.
 - d) Remove lid and filter from vehicle. Set aside for later modification. See FIG. #2
- 3) Remove, modify and replace air box base.
 - a) Unbolt three 10mm bolts that fasten the air box base and remove base from vehicle.
 - b) Remove and discard tube from air box base. See FIG #3
 - c) Remove insulation pad from air box base. Use a pliers to remove the securing clips. See FIG #4
 - d) Replace modified air box base in vehicle.
- 4) Assemble AIRAID.
 - a) Unbolt MAF from air box lid. See FIG#5
 - b) Assemble the two Airaid dams using the hardware provided. See FIG#6, 6a, 8
 - c) Position and bolt the MAF and Filter Adapter Tube onto the Airaid dam with the supplied gasket and hardware. See FIG# 6,6a, 9
 - d) Position air filter on to adapter. Finger tighten for now.
- 5) Install AIRAID.
 - a) Position over air box base. Rotate filter as necessary to clear air box base. Snap onto base.
 - b) (Skip this step for 2001 and earlier models) Install the dam extension using the hardware provided as shown. See FIG# 7, 7a
 - c) Reconnect MAF to inlet tube and tighten clamp.
 - d) Reconnect MAF wire harness.
 - e) Press weather seal onto air dam.
- 6) Finishing up AIRAID Installation.
 - a) Check for any foreign objects in the air flow path.
 - b) Reconnect battery cable. Double check your work.

Note: If your vehicle is equipped with a breather hose that is disconnected after installation, insert the small filter provided into the hole in the cold air dam (on the filter side of the dam). Secure hose to the nipple on the filter that is protruding through the panel.



FIG. #1



FIG. #2





FIG. #3



FIG. #4

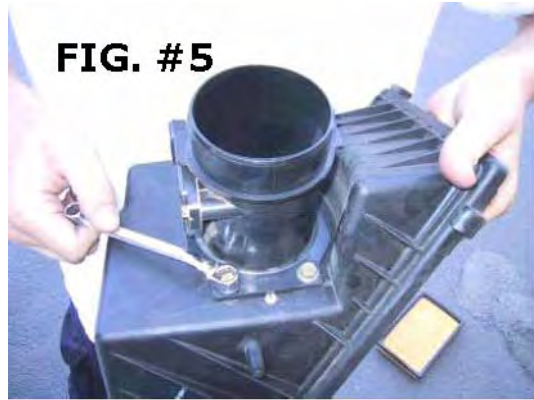

FIG. #5



FIG. #6



FIG. #6a



FIG. #7



FIG. #7a



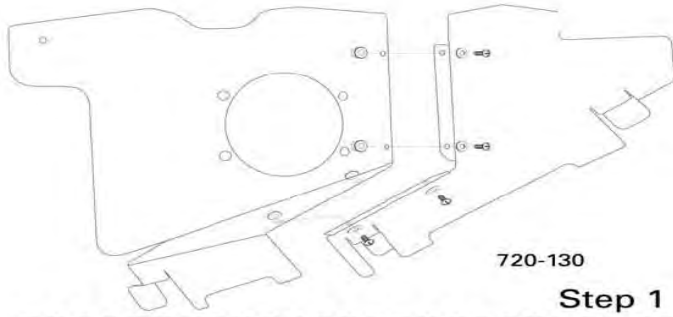
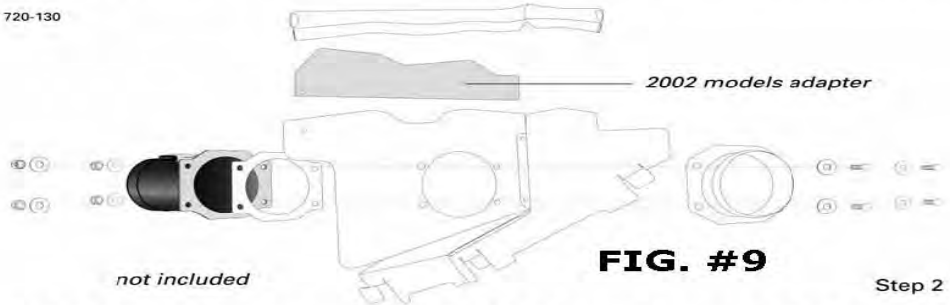

FIG. #8

720-130

Step 1

720-130



2002 models adapter

not included

FIG. #9

Step 2

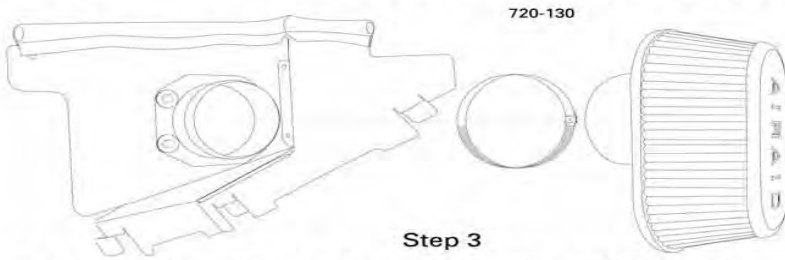

720-130

Step 3



Product has been granted a California Air Resources Board (CARB) exemption, an "EJ" number and it is 50-state legal, per the manufacturer's application guide.

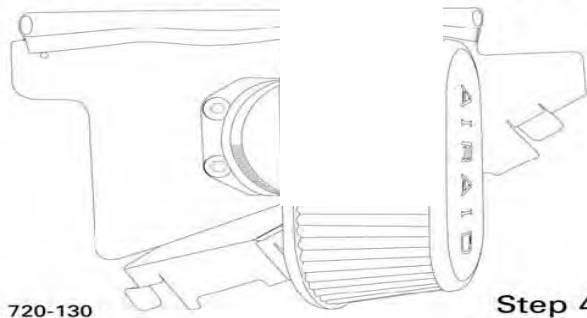

720-130

Step 4

SynthaMax

Do Not Oil

Synthamax Air Filters do not require oil. Service air filter as needed by cleaning with common non-petroleum all-purpose household cleaner and water. Simple Green®, Formula 409® or equivalent works great. Apply cleaner to outside of air filter and allow to soak. Then flush filter clean from the inside out with a garden hose and repeat steps if necessary. Do not apply high pressure water or air to clean filter. Allow filter to air dry and reinstall.

