

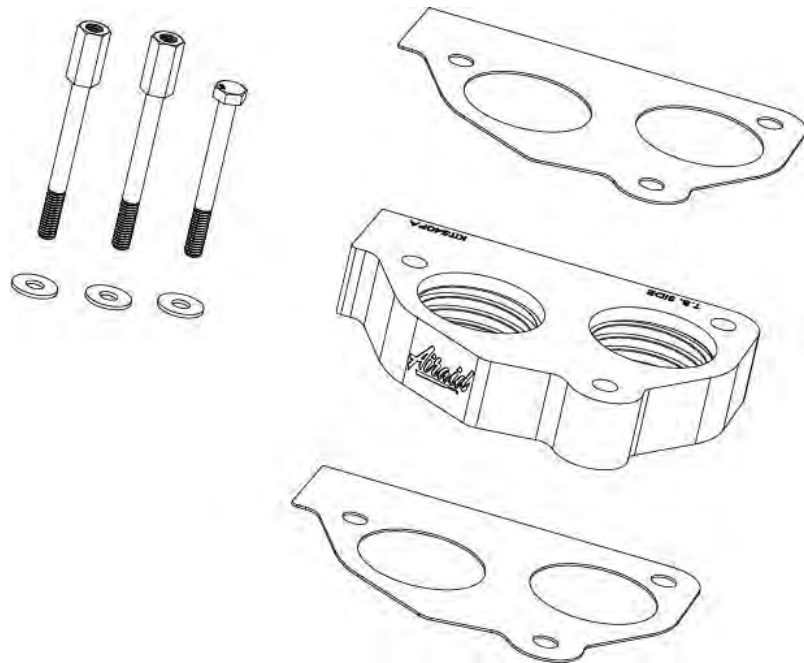

# # 200-540 INSTALLATION INSTRUCTIONS 87-95 C/K 4.3, 5.0, 5.7L 94-95 S-10 4.3L

Thank you for purchasing the AIRAID Throttle Body Spacer. Please read the instruction manual carefully before proceeding with the installation. Your AIRAID Throttle Body Spacer was carefully inspected and packaged. Check that no parts are missing, or were damaged during shipping. If you need any assistance please call 1-800-858-3333 to speak with a representative in our Customer Service Center before returning the product. *Thank you for selecting AIRAID.*

**THROTTLE BODY SPACER FOR VEHICLES LISTED ARE  
50 STATE LEGAL. SEE AIRAID.COM FOR CARB STATUS  
ON EACH PART FOR A SPECIFIC VEHICLE.**



<b>Parts List</b>		
AIR-KIT540PA	Aluminum Plate	(1)
AIR-KIT540G	Gasket	(2)
AIR-KIT540H	Hardware	
	Drilled & Tapped Bolts	(2)
	Plain Bolt	(1)
	8mm Flat Washers	(3)

<b>Tools List</b>
1/2" Socket
Standard Screwdriver

## ***Installation Instructions. Read Me!***

1. **DISCONNECT NEGATIVE (-) BATTERY CABLE.**
2. Remove air cleaner
3. Using 1/2" socket, remove (3) 5/16" bolts.  
\* **Please Note: Some units have bolts that are drilled and tapped for air cleaner mounting studs.**
4. It is not necessary to remove the fuel lines.
5. Remove fuel line bracket from transmission. (Located on drivers side of bell housing)
6. Lift throttle body unit.
7. Remove gasket and clean surfaces.
8. Install power plate using (2) gaskets.
  - A. Locate first gasket between TBI unit and power plate.
  - B. Locate second gasket between power plate and manifold.
9. Install power plate using (2) drilled and tapped bolts, (1) plain bolt, and (3) 8mm flat washers. **Refer to Step 3**
10. Replace air cleaner studs if applicable.
11. Inspect & Test throttle linkage for full Open & Closed travel before driving. Some cruise or kickdown cables may require adjustment. Please refer to the vehicles service manual for proper adjustment.
12. Reinstall the air cleaner
13. Reinstall fuel line bracket. Refer to Step 5
7. Reconnect negative battery cable. Enjoy!

***The sound of power...The "whistle" means its working!***

Transmission Showing Fuel Line Bracket

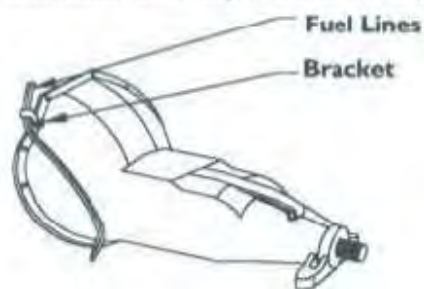

Throttle Body Showing Bolts, Gaskets, and Plate

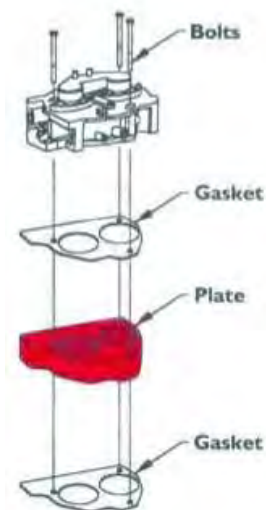

AIR-I20540C  
REV 8.10.20