



Installation Instructions

For Part Numbers:

| | |
|---------|--|
| 200-129 | 700-469 Airaid Oiled Media Filter |
| 201-129 | 701-469 SynthaMax Dry Media Filter - Red |
| 202-129 | 702-469 SynthaMax Dry Media Filter - Black |
| 203-129 | 703-469 SynthaMax Dry Media Filter - Blue |

2001-04 Chevrolet Silverado 2500HD/3500HD
 2001-04 GMC Sierra 2500HD/3500HD
 6.6L V8 Duramax Diesel "LB7"
 (Will NOT fit the 2004 "LLY" Engine)

Component Identification

| | | |
|-----|--------------------------|---|
| 1. | Airaid Premium Filter | 1 |
| 2. | MAF Panel | 1 |
| 3. | Rear Air Dam | 1 |
| 4. | Filter Adapter | 1 |
| 5. | Airaid Intake Tube | 1 |
| 6. | Urethane Hump Hose | 1 |
| 7. | Urethane Coupler | 1 |
| 8. | Weather Strip 19 1/2" | 1 |
| 9. | 6-32 x 5/16" Screw | 5 |
| 10. | #6 Flat Washer | 5 |
| 11. | 6-32 Keps Nut | 5 |
| 12. | 1/4 - 20 x 5/8" Hex Bolt | 3 |
| 13. | 1/4" Flat Washer | 7 |
| 14. | M6-1x 25 Hex Bolt | 4 |
| 15. | 8-32 x 1/2" Button Head | 2 |
| 16. | Steel Washer | 2 |
| 17. | #72 Hose Clamp | 2 |
| 18. | #60 Hose Clamp | 2 |
| 19. | T20 Security Bit | 1 |
| 20. | Airaid Decal | 1 |

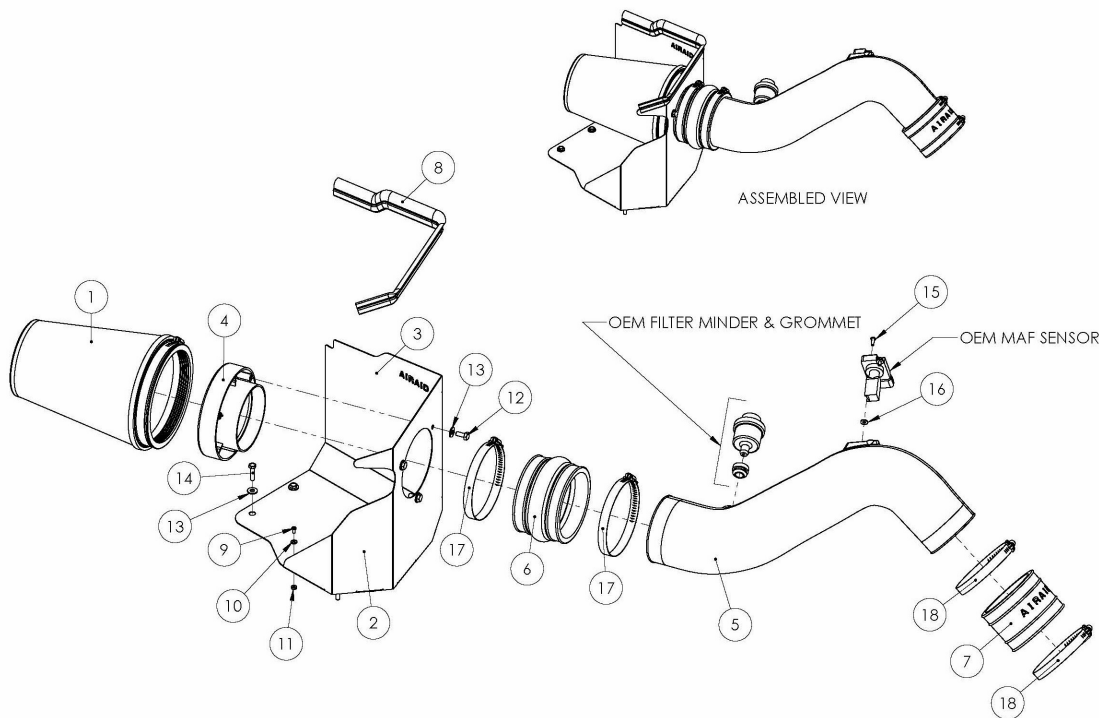

Full color instructions can be viewed on our web site at Airaid.com.



1. Disconnect the negative battery cable.
A.) Disconnect the Mass Air Flow (M.A.F.) sensor wiring harness. Using the supplied T-20 Security bit, remove the two screws and the M.A.F. sensor from the tube (save the sensor for reuse).
B.) Loosen the hose clamps on each end of the factory intake tube assembly.

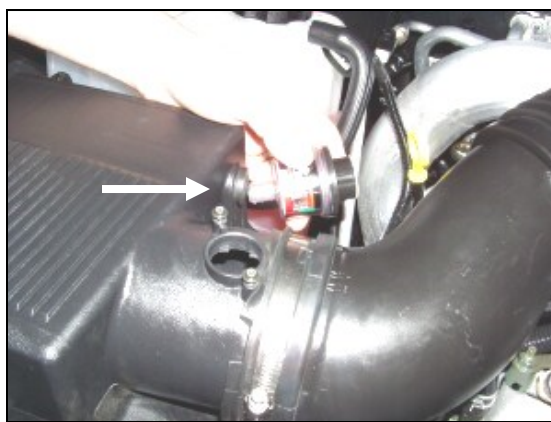

2. Remove the factory filter minder and grommet from the side of the factory airbox (save for reuse).



3. Remove the factory intake tube assembly from the engine. Rock the factory air box back and forth and remove it from the vehicle. There are only grommets holding it in, no bolts.

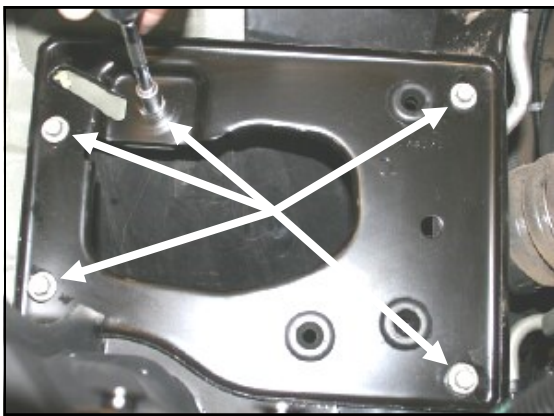

4. Using a 10mm socket, remove the five bolts and mounting plate from the engine compartment.

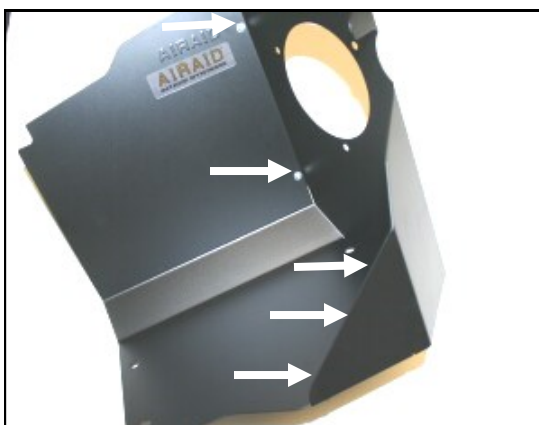

5. Assemble the Airaid Cool Air Dam panels (#2, #3) using five 6-32 x 5/16" screws (#9), #6 flat washers (#10) and 6/32 keps nuts (#11). Apply the Airaid Foil Decal onto the Panel as shown.

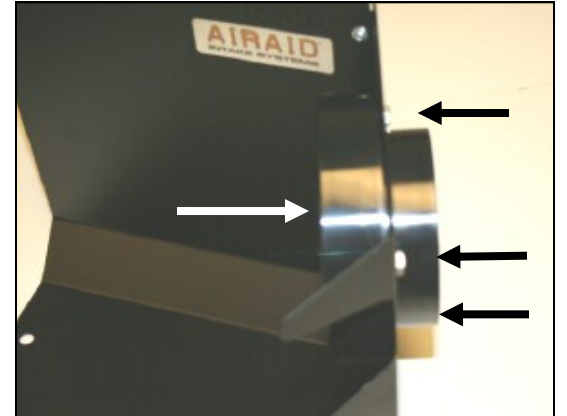

6. Using three 1/4-20 x 5/8" hex bolts (#12) and 1/4" flat washers (#13), install the filter adapter (#4) onto the Airaid Cool Air Dam.

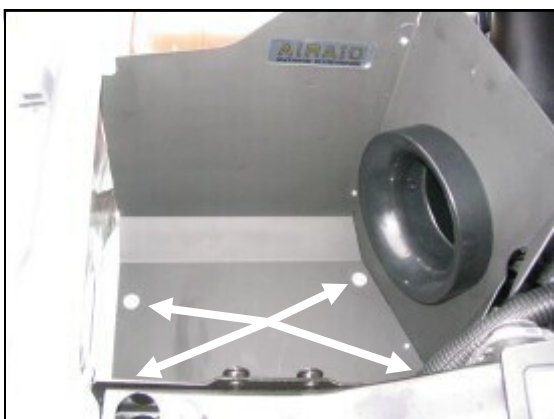

7. Install the Airaid Cool Air Dam assembly in the engine compartment using four M6-1x25 hex bolts (#14) and 1/4" flat washers (#13).

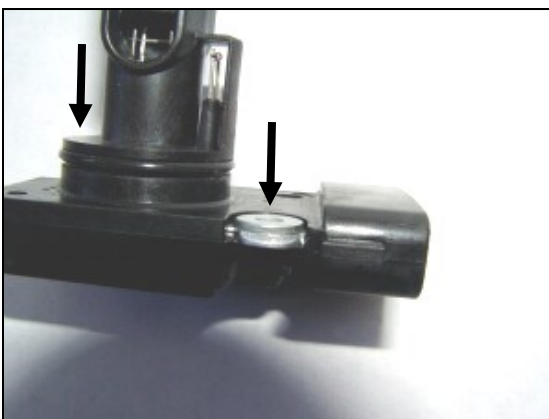

8. Place two steel washers (#16) into the recessed portions of the MAF sensor mounting holes.



9. Using two 8-32 x 1/2" button head screws (#15) install the factory M.A.F. sensor in the Airaid intake tube (#5) **DO NOT USE THE FACTORY SCREWS!** (Note: Sensor must be installed in the direction shown in the picture, with steel washers between it and the tube.)

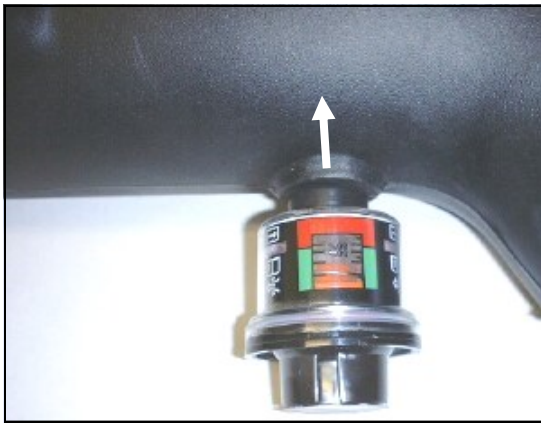

10. Install the factory rubber grommet and air filter minder into the Airaid intake tube.



11. Install the urethane hump hose (#6) and two #72 hose clamps (#17) onto the large end of the Airaid intake tube. (Note: Leave hose clamps loose until final assembly.)



12. Install the urethane coupler (#7) and two #60 hose clamps (#18) onto the small end of the Airaid intake tube. (Note: Leave hose clamps loose until final assembly.)

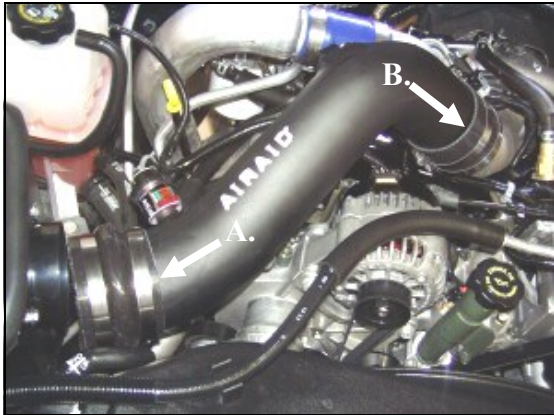

13. A.) Install the hump hose end of the Airaid intake tube assembly onto the filter adapter first. B.) Slip the coupler end of the tube over the factory turbocharger inlet. Adjust for fit, and tighten the hose clamps. (Note: There should be a gap in between the Airaid intake tube and the air filter adapter.)



14. Install the Airaid Premium Filter (#1) onto the filter adapter, and tighten the hose clamp. Install the weather strip (#8) onto the Airaid Cool Air Dam. Reconnect the M.A.F. sensor wiring harness. (Note: Start from one corner and work your way around to insure proper alignment of the weather strip.)

15. Double check your work!
Make sure there is no foreign material in the intake path. Make sure all clamps, hoses, bolts, and screws are tight.

16. Reconnect the negative battery cable!

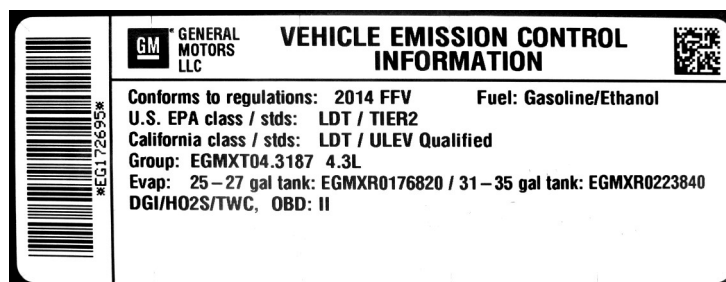

WARNING! If your vehicle has a Vehicle Emission Control Information decal affixed to the factory airbox, a new replacement label must be obtained and installed in a readily visible position in the engine compartment in order to remain CARB compliant. Failure to do so will prevent the vehicle from passing a smog check. Replacement labels can be ordered from your local dealership. Regulations state that the VECI label shall not be affixed to any equipment which is easily detached from the vehicle. Label placement, under the hood on a painted surface is recommended.

Thank you for purchasing the Airaid Intake System. Contact Airaid @ (800) 498-6951 8:00 AM - 5:00 PM MST weekdays for questions regarding fit or instructions that are not clear to you. Your Airaid Intake System was carefully inspected and packaged. Check that no parts are missing, or were damaged during shipping. If any parts are missing, contact Airaid. The air filter element is protected from direct exposure to water and debris; care should be taken not to drive through deep water. WATER INGESTION IS THE DRIVERS RESPONSIBILITY! The air filter is reusable and should be cleaned periodically.

FILTER IDENTIFICATION

700-469 Airaid Oiled Media
702-469 Airaid SynthaMax Dry Media - Black

701-469 Airaid SynthaMax Dry Media - Red
703-469 Airaid SynthaMax Dry Media - Blue

For your Oiled media filter we suggest using the AIRAID Filter Tune-Up Kit!



P/N 790-551 Aerosol Spray
P/N 790-550 Squeeze Spray



SynthaMax

Do Not Oil

Synthamax Air Filters do not require oil. Service air filter as needed by cleaning with common non-petroleum all-purpose household cleaner and water. Simple Green®, Formula 409® or equivalent works great. Apply cleaner to outside of air filter and allow to soak. Then flush filter clean from the inside out with a garden hose and repeat steps if necessary. Do not apply high pressure water or air to clean filter. Allow filter to air dry and reinstall.