



Installation Instructions

For Part Numbers:

200-167	700-469 Airaid Oiled Media Filter
201-167	701-469 SynthaMax Dry Media Filter - Red
203-167	703-469 SynthaMax Dry Media Filter - Blue

**2005 Chevrolet Silverado 2500HD/3500HD
6.6L V8 Duramax Diesel
(Does Not Fit 2005 GMC)**

Component Identification

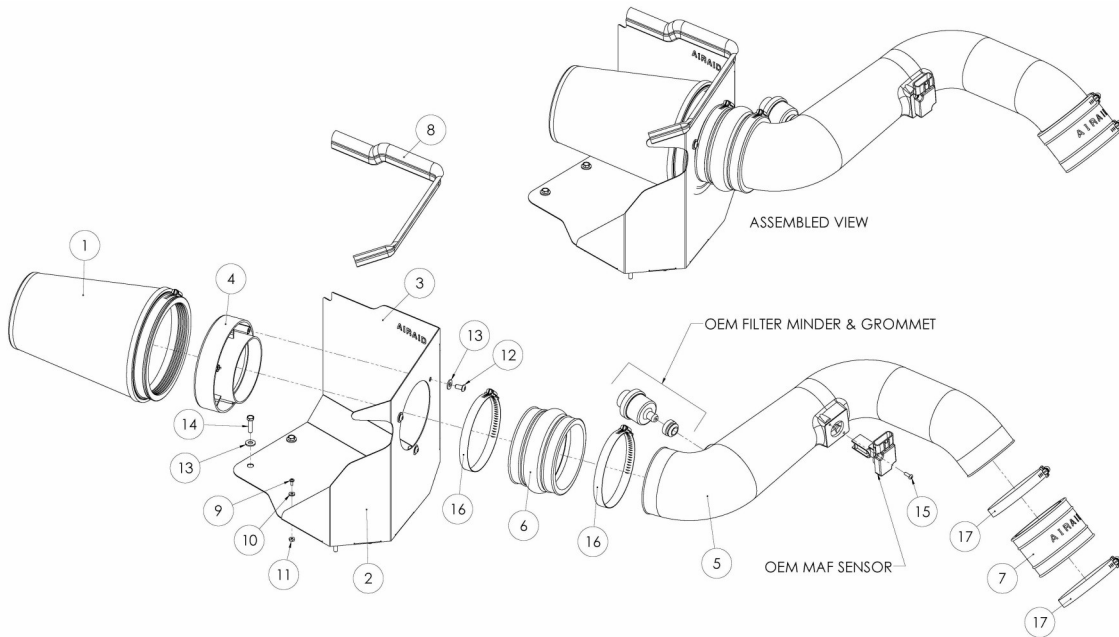

1.	Airaid Premium Filter	1
2.	Front Cool Air Dam Panel	1
3.	Rear Cool Air Dam Panel	1
4.	Filter Adapter	1
5.	Airaid Intake Tube	1
6.	Urethane Hump Hose	1
7.	Urethane Coupler	1
8.	Weather Strip 21"	1
9.	6-32 x 5/16" Screw	5
10.	#6 Flat Washer	5
11.	6-32 Keps Nut	5
12.	1/4-20 x 1/2" Button Head Bolt	3
13.	1/4" Flat Washer	7
14.	M6-1x25 Hex Bolt	4
15.	8-32 x 1/2" Button Head Screw	2
16.	#72 Hose Clamp	2
17.	#60 Hose Clamp	2
18.	T20 Security Bit	1
19.	Airaid Decal	1

Full color instructions can be viewed on our web site at Airaid.com.



1. **Disconnect the negative battery cable.** Disconnect the Mass Air Flow (M.A.F.) sensor wiring harness. Using the supplied T-20 Security bit, remove the two screws and the M.A.F. sensor from the tube (save the sensor for reuse). Loosen the hose clamps on each end of the factory intake tube assembly.



2. Remove the factory filter minder and grommet.



3. Remove the factory intake tube assembly from the engine. Rock the factory air box back and forth and remove it from the vehicle. There are only grommets holding it in, no bolts.



4. Using a 10mm socket, remove the five bolts and mounting plate from the engine compartment.

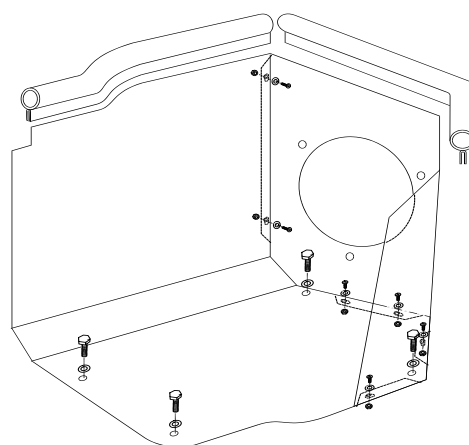

5. Assemble the Airaid Cool Air Dam panels (#2, #3) using five 6-32 x 5/16" screws (#9), #6 flat washers (#10) and 6/32 keps nuts (#11).

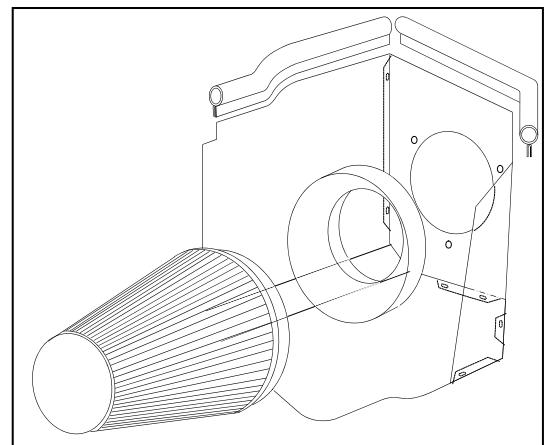

6. Using three 1/4-20 x 1/2" button head bolts (#12) and 1/4" flat washers (#13), install the filter adapter (#4) onto the Airaid Cool Air Dam.

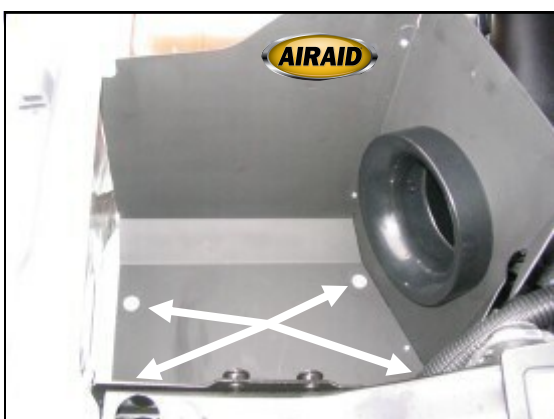

7. Install the Airaid Cool Air Dam assembly in the engine compartment using four M6-1x25 hex bolts (#14) and 1/4" flat washers (#13). Apply the Airaid Foil Decal onto the Panel as shown.



8. Using two 8-32 x 1/2" button head screws (#15) install the factory M.A.F. sensor in the Airaid intake tube (#5) **DO NOT USE THE FACTORY SCREWS!** (Note: Sensor must be installed in the direction shown in the picture.)



9. Install the factory rubber grommet and air filter minder into the Airaid intake tube.



10. Install the urethane hump hose (#6) and two #72 hose clamps (#16) onto the large end of the Airaid intake tube. *(Note: Leave hose clamps loose until final assembly.)*



11. Install the urethane coupler (#7) and two #60 hose clamps (#17) onto the small end of the Airaid intake tube. *(Note: Leave hose clamps loose until final assembly.)*



12. Install the Airaid intake tube assembly onto the engine. Install the hump hose end onto the filter adapter first and then slip the coupler end of the tube onto the aluminum intake tube. Adjust for fit, and tighten the hose clamps. *(Note: There should be a gap in between the Airaid intake tube and the air filter adapter.)*

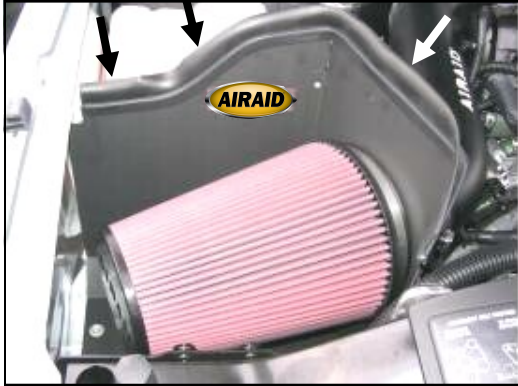

13. Install the Airaid Premium Filter (#1) onto the filter adapter, and tighten the hose clamp. Install the weather strip (#8) onto the Airaid Cool Air Dam. Reconnect the MAF sensor wiring harness. *(Note: Start from one corner and work your way around to insure proper alignment of the weather strip.)*

14. Double check your work!

Make sure there is no foreign material in the intake path. Make sure all clamps, hoses, bolts, and screws are tight.

15. Reconnect the negative battery cable!

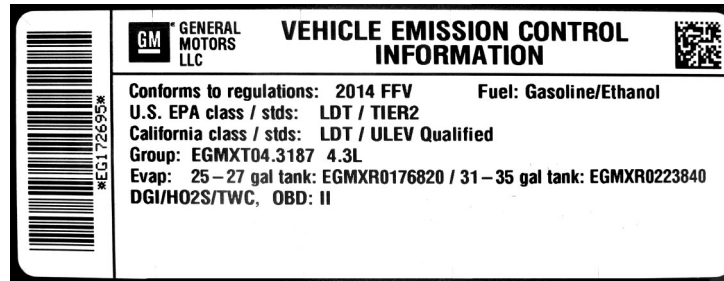

WARNING! If your vehicle has a Vehicle Emission Control Information decal affixed to the factory airbox, a new replacement label must be obtained and installed in a readily visible position in the engine compartment in order to remain CARB compliant. Failure to do so will prevent the vehicle from passing a smog check. Replacement labels can be ordered from your local dealership. Regulations state that the VECI label shall not be affixed to any equipment which is easily detached from the vehicle. Label placement, under the hood on a painted surface is recommended.

Thank you for purchasing the Airaid Intake System. Contact Airaid @ (800) 498-6951 8:00 AM - 5:00 PM MST weekdays for questions regarding fit or instructions that are not clear to you. Your Airaid Intake System was carefully inspected and packaged. Check that no parts are missing, or were damaged during shipping. If any parts are missing, contact Airaid. The air filter element is protected from direct exposure to water and debris; care should be taken not to drive through deep water. WATER INGESTION IS THE DRIVERS RESPONSIBILITY! The air filter is reusable and should be cleaned periodically.

FILTER IDENTIFICATION

700-469 Airaid Oiled Media

701-469 Airaid Synthamax Dry Media - Red

703-469 Airaid Synthamax Dry Media - Blue

For your Oiled media filter we suggest using the AIRAID Filter Tune-Up Kit!

Synthamax

Do Not Oil



Synthamax Air Filters do not require oil. Service air filter as needed by cleaning with common non-petroleum all-purpose household cleaner and water. Simple Green®, Formula 409® or equivalent works great. Apply cleaner to outside of air filter and allow to soak. Then flush filter clean from the inside out with a garden hose and repeat steps if necessary. Do not apply high pressure water or air to clean filter. Allow filter to air dry and reinstall.

P/N 790-551 Aerosol Spray
P/N 790-550 Squeeze Spray