



## Installation Instructions

For Part Numbers:

200-186	700-469 Airaid Oiled Media Filter
201-186	701-469 SynthaMax Dry Media Filter - Red
202-186	702-469 SynthaMax Dry Media Filter - Black

**2006 Chevrolet Silverado 1500**  
**2007 Chevrolet Silverado Classic**  
**1500/1500HD/2500HD/3500**  
**4.8L V8, 5.3L V8, 6.0L V8**  
**With Electric Cooling Fan & High Profile Hood**

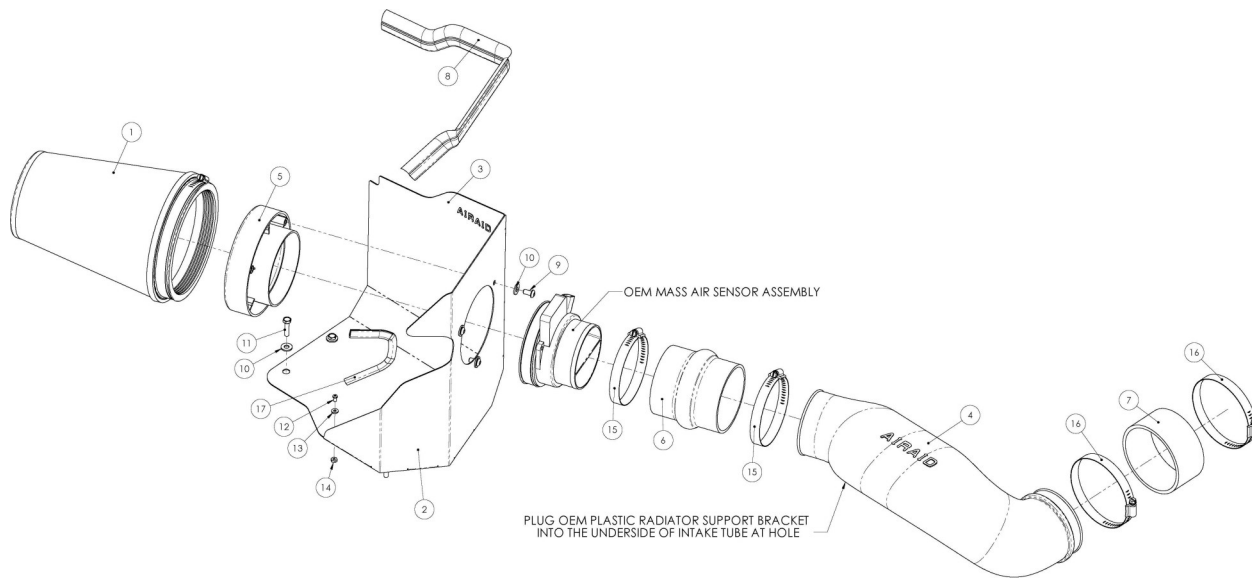

### Component Identification

1.	Airaid Premium Filter	1
2.	MAF Panel Coated	1
3.	Rear Air Dam Coated	1
4.	Modular Intake Tube	1
5.	Black Filter Adapter	1
6.	Urethane Hump Hose	1
7.	Urethane Coupler	1
8.	Weather Strip 21"	1
9.	1/4"-20x1/2" SS Button Head	3
10.	1/4" Flat Washer	7
11.	M6x1x25 Hex Bolt	4
12.	6-32 x 5/16" Screw	5
13.	#6 Flat Washer	5
14.	6-32 Keps Nut	5
15.	#60 Hose Clamp	2
16.	#64 Hose Clamp	2
17.	Rubber Trim 7"	1
18.	Airaid Decal	1

Full color instructions can be viewed on our web site at [Airaid.com](http://Airaid.com).



**1. Disconnect the negative battery cable.**  
Using a 5/16" socket, remove one bolt on the top of the beauty cover. Set the bolt and the cover aside for re-installation later.

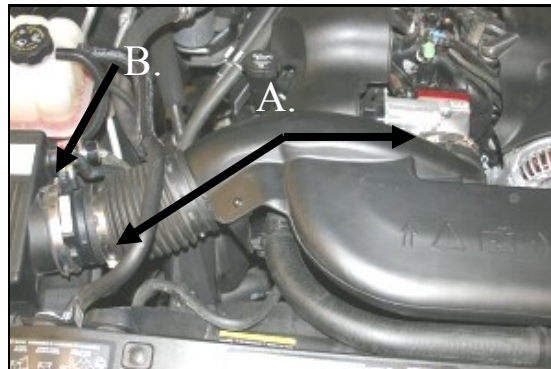

**2. A.)** Loosen the hose clamps on both ends of the factory intake tube. **B.)** Next loosen the hose clamp on the Mass Air Flow sensor where it clamps on the factory airbox.



**3.** Using a screwdriver, pry the factory tube away from the plastic clamp on the radiator hose, and remove the tube.



**4.** Without disconnecting the electrical connector, remove the Mass Air Flow sensor from the factory airbox, and set it aside.



**5.** Grab the factory airbox and rock it back and forth, and remove it from the vehicle. It is only held in by grommets, no bolts.

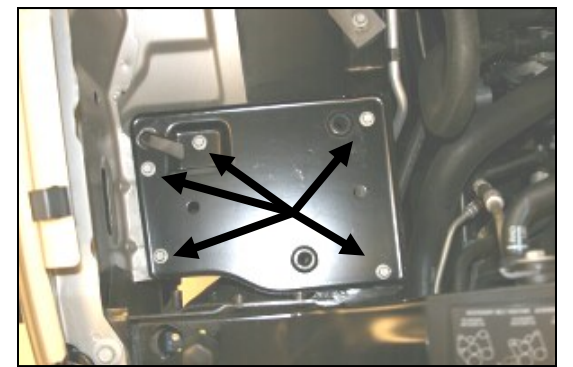

**6.** Remove 5 bolts and remove the factory airbox mounting plate.



**7.** Assemble the two Cool Air Dam panels (#2) and (#3) using the five supplied screws (#12), washers (#13), and nuts (#14). Apply the Airaid Foil Decal onto the Panel as shown.

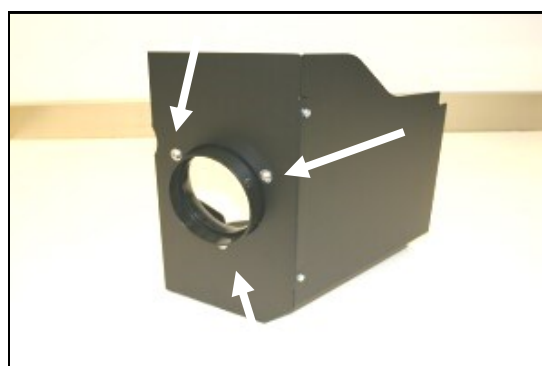

**8.** Install the filter adapter (#5) into the CAD using three button head bolts (#9), and washers (#10).

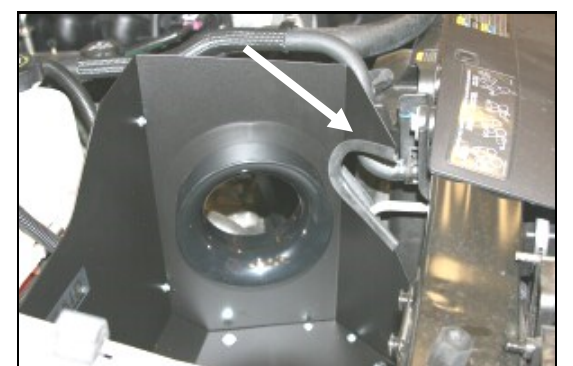

**9.** Install the assembled CAD in place of the factory airbox using four bolts (#11) and washers (#10). Do not over tighten the bolts. Install the rubber trim (#17) as shown at the arrow.



10. Re-install the Mass Air Flow sensor onto the filter adapter, and tighten the hose clamp. Make sure the rectangle area next to where the wiring harness connects is pointing up.



11. Install the urethane hump hose (#6) on the Mass Air Flow sensor with two #60 hose clamps (#15). Next install the urethane coupler (#7) on the throttle body with two #64 hose clamps (#16).



12. Install the Modular Intake Tube into the hump hose first, and then into the throttle body. Adjust for fit, and tighten all four hose clamps. Re-insert the plastic piece from step #3 into the hole on the bottom of the MIT.



13. Install the Airaid Premium Filter (#1) onto the filter adapter (#5), and tighten the hose clamp. Next install the weather strip (#8) onto the top of the CAD as shown. For ease of installation start at the fender, and work towards the radiator.



14. Re-install the beauty cover and bolt removed in step #1.

### 15. Double check your work!

Make sure there is no foreign material in the intake path. Make sure all clamps, hoses, bolts, and screws are tight.

### 16. Reconnect the negative battery cable!

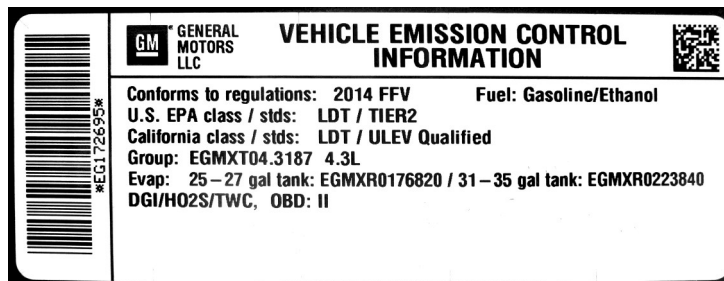

**WARNING!** If your vehicle has a Vehicle Emission Control Information decal affixed to the factory airbox, a new replacement label must be obtained and installed in a readily visible position in the engine compartment in order to remain CARB compliant. Failure to do so will prevent the vehicle from passing a smog check. Replacement labels can be ordered from your local dealership. Regulations state that the VECI label shall not be affixed to any equipment which is easily detached from the vehicle. Label placement, under the hood on a painted surface is recommended.

Thank you for purchasing the Airaid Intake System. Contact Airaid @ (800) 498-6951 8:00 AM - 5:00 PM MST weekdays for questions regarding fit or instructions that are not clear to you. Your Airaid Intake System was carefully inspected and packaged. Check that no parts are missing, or were damaged during shipping. If any parts are missing, contact Airaid. The air filter element is protected from direct exposure to water and debris; care should be taken not to drive through deep water. WATER INGESTION IS THE DRIVERS RESPONSIBILITY! The air filter is reusable and should be cleaned periodically.

## FILTER IDENTIFICATION

700-469 Airaid Oiled Media

701-469 Airaid SynthaMax Dry Media - Red

702-469 Airaid SynthaMax Dry Media - Black

For your Oiled media filter we suggest using the AIRAID Filter Tune-Up Kit!

*SynthaMax*

**Do Not Oil**



P/N 790-551 Aerosol Spray  
P/N 790-550 Squeeze Spray



Synthamax Air Filters do not require oil. Service air filter as needed by cleaning with common non-petroleum all-purpose household cleaner and water. Simple Green®, Formula 409® or equivalent works great. Apply cleaner to outside of air filter and allow to soak. Then flush filter clean from the inside out with a garden hose and repeat steps if necessary. Do not apply high pressure water or air to clean filter. Allow filter to air dry and reinstall.