



Installation Instructions

For Part Numbers:

200-189	700-469 Airaid Oiled Media Filter
202-189	702-469 SynthaMax Dry Media Filter - Black
203-189	703-469 SynthaMax Dry Media Filter - Blue

2006 GMC Sierra 2500HD/3500HD
2007 GMC Sierra "Classic" 2500HD/3500HD
6.6L V8 Duramax Diesel "LLY" or "LBZ"
With Low Profile Hood

Component Identification

1.	Airaid Premium Filter	1
2.	MAF Panel	1
3.	Rear Panel	1
4.	MAF Adapter Tube	1
5.	Weather Strip 20 3/4"	1
6.	1/4"-20x1/2" Button Head	3
7.	1/4" Flat Washer	7
8.	8-32x1/2" Button Head Screw	2
9.	M6-1x25 Hex Bolt	4
10.	6-32x 5/16" Screw	5
11.	#6 Flat Washer	5
12.	6-32 Keps Nut	5
13.	Rubber Trim 6 1/2"	1

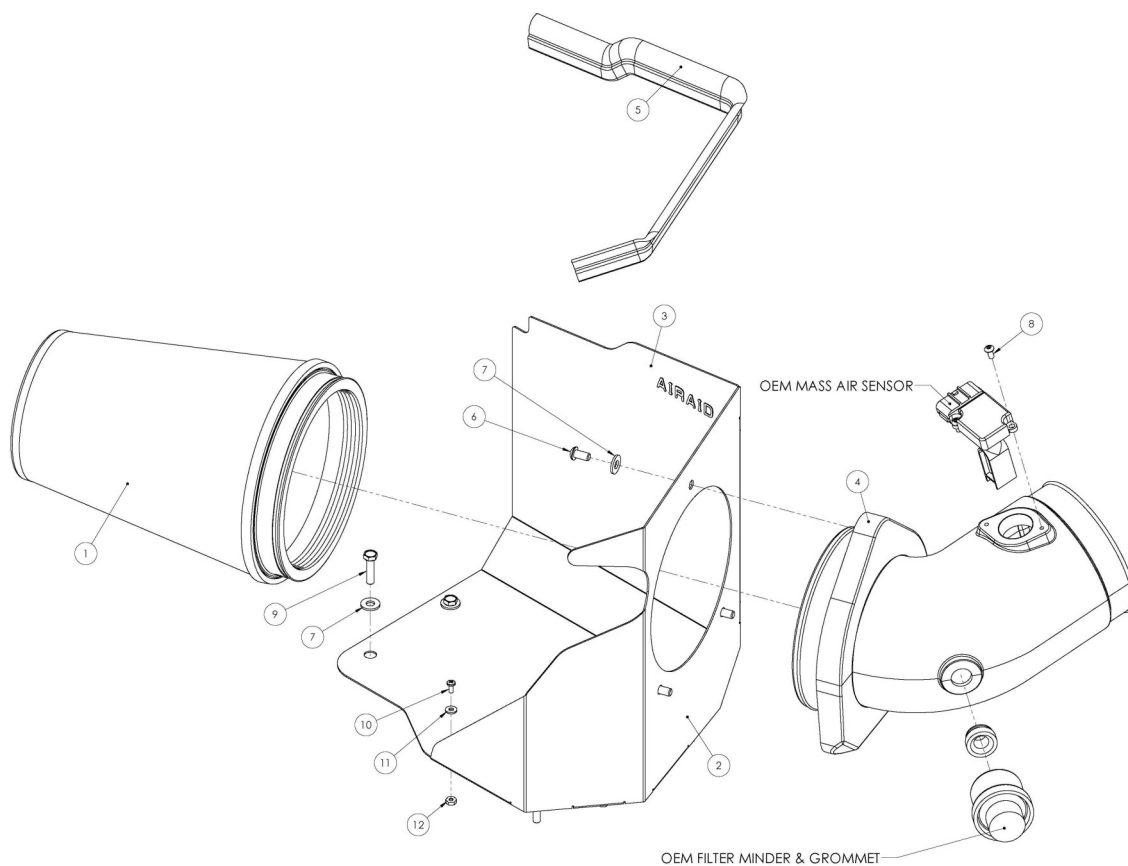

Full color instructions can be viewed on our web site at Airaid.com. Use the **Product Search** function to find your part number, and click **View Details**.



1. **Disconnect the negative battery cable.**
Using a 5/16" socket or flat screwdriver, loosen the hose clamp that holds the factory airbox to the flexible intake tube.



2. Using a #20 Torx bit, remove 2 screws holding the Mass Air Flow sensor to the factory airbox tube.



3. Without disconnecting the wiring harness, remove the Mass Air Flow sensor from the factory airbox, and set it aside.



4. Slide the flexible intake tube off of the factory airbox and then rock the airbox back and forth to free it from the mounting grommets, next lift it straight up and remove it from the vehicle.



5. Remove the factory filter minder and grommet from the factory airbox. Save them for later use.



6. Using a 10mm socket, remove 5 bolts from the factory airbox mounting plate. Remove the plate from the vehicle.



7. Assemble the two Cool Air Dam panels (#2) and (#3) as shown, using the five 6-32 screws (#10), washers (#11), and nuts (#12)

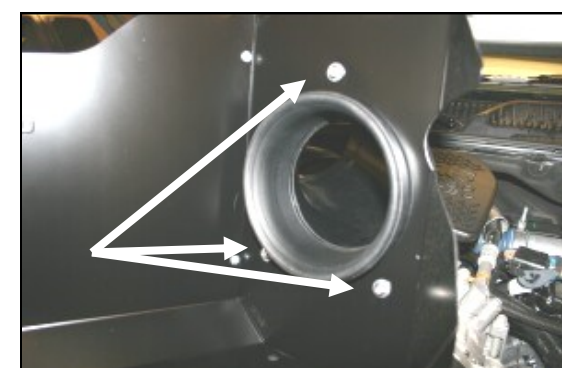

8. Install the Airaid intake tube (#4) into the Cool Air Dam using the three 1/4"-20x1/2" button head bolts (#6), and washers (#7) as shown.



9. Re-install the factory grommet and filter minder removed in step #5 into the Airaid intake tube.

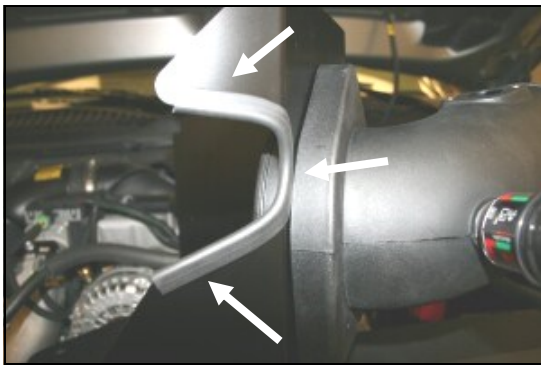

10. Install the provided rubber trim (#13) on the CAD as shown.



11. Install the assembled CAD into the vehicle where you removed the factory mounting plate in step #6. Use four bolts (#9), and washers (#7) to secure the CAD. Do not over tighten the bolts.



12. Re-position the factory intake tube onto the Airaid tube, and tighten the hose clamp. Next re-install the Mass Air Flow sensor into the Airaid tube **using the two provided Button Head screws (#8). Do not use the factory screws!** Do not over tighten!

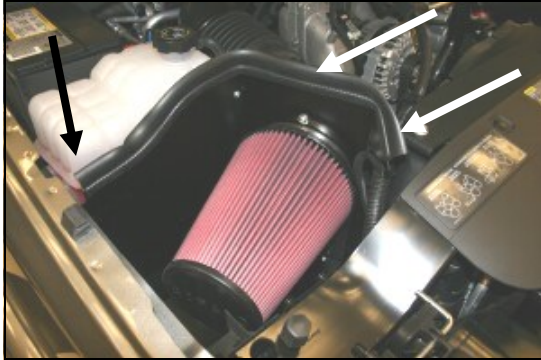

13. Install the Airaid Premium Filter (#1) onto the Airaid intake tube (#4), and tighten the hose clamp. Now install the provided weather strip (#5) on the top of the CAD. For ease of installation, start near the fender and work your way towards the radiator.

14. Double check your work!

Make sure there is no foreign material in the intake path. Make sure all clamps, hoses, bolts, and screws are tight.

15. Reconnect the negative battery cable!

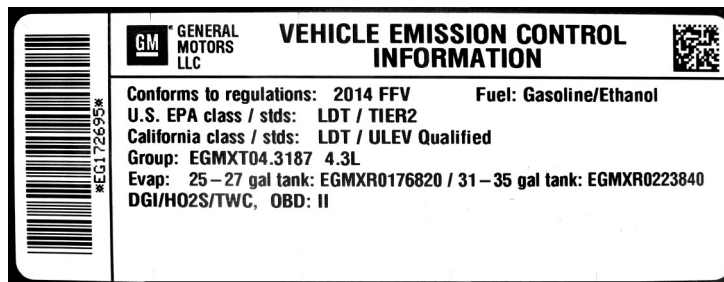

WARNING! If your vehicle has a Vehicle Emission Control Information decal affixed to the factory airbox, a new replacement label must be obtained and installed in a readily visible position in the engine compartment in order to remain CARB compliant. Failure to do so will prevent the vehicle from passing a smog check. Replacement labels can be ordered from your local dealership. Regulations state that the VECI label shall not be affixed to any equipment which is easily detached from the vehicle. Label placement, under the hood on a painted surface is recommended.

Thank you for purchasing the Airaid Intake System. Contact Airaid @ (800) 498-6951 8:00 AM - 5:00 PM MST weekdays for questions regarding fit or instructions that are not clear to you. Your Airaid Intake System was carefully inspected and packaged. Check that no parts are missing, or were damaged during shipping. If any parts are missing, contact Airaid. The air filter element is protected from direct exposure to water and debris; care should be taken not to drive through deep water. WATER INGESTION IS THE DRIVERS RESPONSIBILITY! The air filter is reusable and should be cleaned periodically.

FILTER IDENTIFICATION

702-469 Airaid SynthaMax Dry Media - Black

700-469 Airaid Oiled Media

703-469 Airaid SynthaMax Dry Media - Blue

For your Oiled media filter we suggest using the AIRAID Filter Tune-Up Kit!



Do Not Oil



P/N 790-551 Aerosol Spray
P/N 790-550 Squeeze Spray



Synthamax Air Filters do not require oil. Service air filter as needed by cleaning with common non-petroleum all-purpose household cleaner and water. Simple Green®, Formula 409® or equivalent works great. Apply cleaner to outside of air filter and allow to soak. Then flush filter clean from the inside out with a garden hose and repeat steps if necessary. Do not apply high pressure water or air to clean filter. Allow filter to air dry and reinstall.