

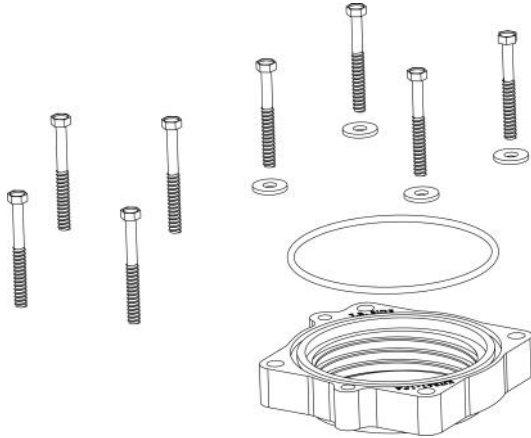

## Installation Instructions Part Number 300-631-1

2009-22 Dodge Ram  
2020 Ram 1500 Classic  
2009 Chrysler Aspen  
2009 Dodge Durango  
5.7L / 6.4L V8



### Parts List

AIR-KIT631-1PA	Aluminum Plate	(1)
AIR-KIT631H	Hardware	
	6mmx63mm Bolt	(4)
	6mmx70mm Bolt	(4)
	6mm Flat Washer	(4)
	O-Ring	(1)

### Tools Required For Installation

### CAUTION!

**This kit contains Two different sets of mounting hardware.**

**NOT LEGAL FOR SALE OR USE ON ANY POLLUTION CONTROLLED MOTOR VEHICLE IN CALIFORNIA OR STATES ADOPTING CALIFORNIA EMISSION PROCEDURES.**

See AIRAID.COM for CARB status on each part for a specific vehicle.

Successful installation of this part requires proper identification of the OEM Throttle Body hardware to prevent severe intake manifold damage.

Please read these instructions in their entirety before beginning the installation.

Thank you for purchasing the Airaid Throttle Body Spacer. Please read the instruction manual carefully before proceeding with the installation. Your Airaid Throttle Body Spacer was carefully inspected and packaged. Check that no parts are missing, or were damaged during shipping. If you need any assistance please call 1-800-858-3333 to speak with a representative in our Customer Service Center before returning the product.

*Thank you for selecting AIRAID.*



#### 1. Disconnect the negative battery cable!

Disconnect the air intake temperature sensor wiring harness by sliding the red tab, and then squeezing the black tab. Loosen two hose clamps, one on each end of the flexible air intake tube. Remove the tube from the vehicle. Lift straight up on the front of engine cover, pull it towards you, and set it aside.



2. Remove the four bolts that secure the throttle body to the intake manifold. Without disconnecting the wiring harness, remove the throttle body from the intake manifold and set it aside.

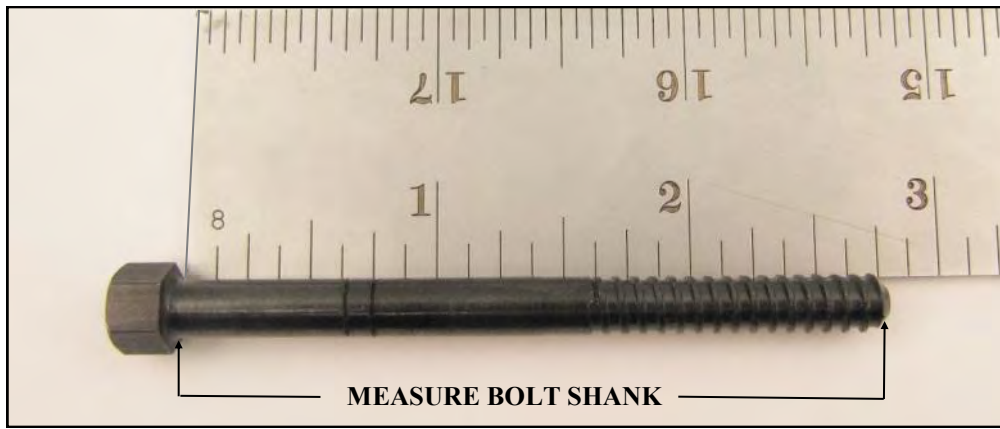

**3. Measure your OEM hardware to determine which Airaid bolts you will need. Measure the shank only. Use the chart below to select the proper bolts.**

**Late models 2012.5-2013**

OEM Green bolt 45mm (1 3/4") use 63mm (2 1/2") bolt , Pack A

**Early models 2009-2012.5**

OEM Silver bolt 55mm (2 1/8") , use 70mm (2 3/4") bolt, Pack B

**Verify the length of all four Airaid bolts before proceeding. Proper identification of the Throttle Body hardware is imperative to prevent severe intake manifold damage.**

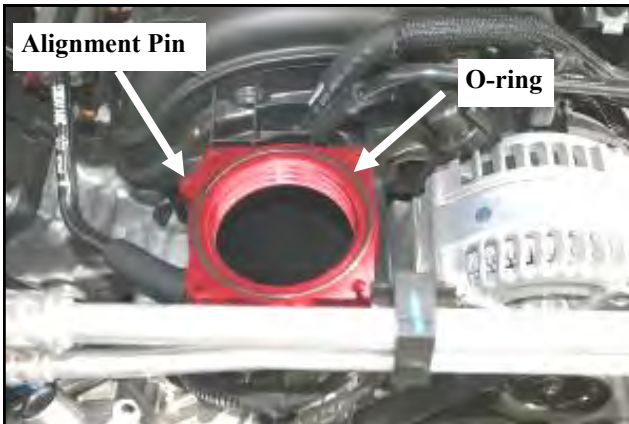

**4. Install the supplied o-ring into the groove on the Airaid Spacer. Next install the spacer onto the intake manifold with the o-ring facing up, making sure that the alignment pin holes are located over the alignment pins.**



**5. Reinstall the throttle body on top of the Airaid Spacer using the four bolts and the washers that were selected in step 3. Tighten the bolts evenly, in an X pattern, to the vehicle manufacturers specifications.**



**6. Reinstall the engine cover and intake tube in the reverse order that they were removed. Make sure to reconnect the temperature sensor.**  
**Re-connect the negative battery cable!**

AIR-I30631-1F  
 Rev. 11/29/21