

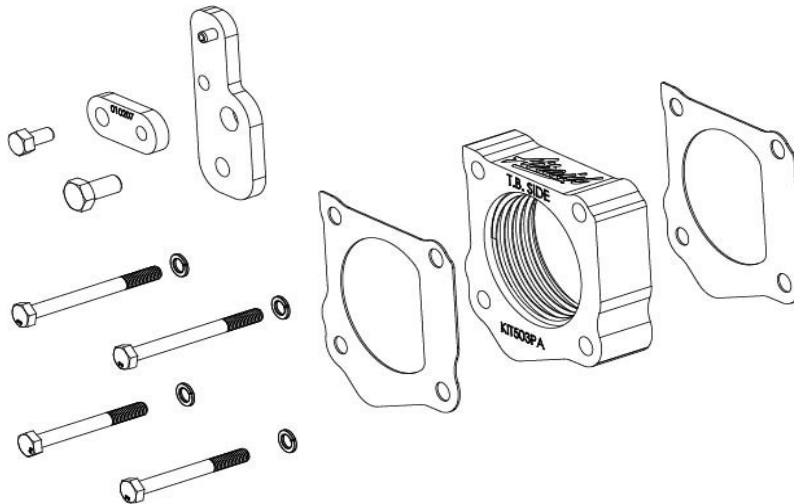

510-503 INSTALLATION INSTRUCTIONS 03-04 Toyota Tacoma 3.4L

Thank you for purchasing the Airaid Throttle Body Spacer. Please read the instruction manual carefully before proceeding with the installation. Your Airaid Throttle Body Spacer was carefully inspected and packaged. Check that no parts are missing, or were damaged during shipping. If you need any assistance please call 1-800-858-3333 to speak with a representative in our Customer Service Center before returning the product.

Thank you for selecting AIRAID.



**THROTTLE BODY SPACERS FOR VEHICLES LISTED
ARE 50 STATE LEGAL. SEE AIRAID.COM FOR CARB
STATUS ON EACH PART FOR A SPECIFIC VEHICLE.**

Parts List

AIR-KIT503PA	Aluminum Plate	(1)
AIR-KIT503G	Gasket	(2)
AIR-KIT503H	Hardware	
	8mm x 90mm Bolts	(2)
	8mm x 110mm Bolts	(2)
	8mm Lock Washers	(4)
	Linkage Bracket Plate	(1)
	10mm x 20mm Bolt	(1)
	Extension Plate	(1)
	5/16\"-18 x 3/8\" Bolt	(1)

Also available for your 03-04 Toyota Tacoma, the Airaid Intake System p/n 510-134. Call today for details!

Tools List

10mm,13mm,14mm,17mm Sockets
12 mm Deep Socket
Ratchet & Extension
12mm Wrench

Installation Instructions. Read Me!

1. **DISCONNECT NEGATIVE (-) BATTERY CABLE.**
2. Remove throttle body air intake assembly.
3. Remove throttle linkage bracket and save 10mm bolt. (Ref. "D")
4. Remove vacuum line clip from intake manifold and save 8mm bolt. (Ref. "E")
5. Remove nuts and studs from the throttle body. (Ref. "B" & "C")
6. Install spacer using (2) gaskets, (2) 8mm x 90mm bolts, (2) 8mm x 110mm bolts, and (4) 8mm lock washers. (Ref. "A", "B", "C")
 - A. Place one gasket between the throttle body and spacer.
 - B. Place second gasket between the spacer and manifold.
7. Install throttle linkage plate using 10mm x 20mm bolt and reinstall throttle linkage bracket using saved 10mm bolt. (Ref. "D")
8. Install extension plate using saved 8mm bolt (Step 4) and attach vacuum line clip to bottom side of extension plate using furnished 5/16"-18 x 3/8" bolt. (Ref. "E") (A slight tube adjustment might be needed.)
9. Inspect & Test throttle linkage for full Open & Closed travel before driving. Some cruise or kick down cables may require adjustment. Please refer to your vehicles service manual for proper adjusting.
10. Reinstall air intake system using Step 2 as an example.
11. Reconnect battery cable. Enjoy!

The sound of power...The "whistle" means its working!

Ref. "A"- (1) Spacer
(2) Gaskets

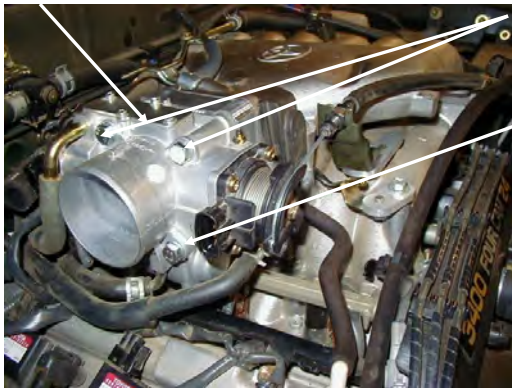

Ref. "B"- (2) 8mm x 90mm Bolts
(2) 8mm Lock Washers

Ref. "C"- (2) 8mm x 110mm Bolts
(2) 8mm Lock Washers

Ref. "D"- (1) Linkage Bracket Plate
(1) 10mm x 20mm Bolt

Ref. "E"- (1) Extension Plate
(1) 5/16"-18 x 3/8" Bolt



AIR-I51503C Rev. 11.16.20