



INSTALLATION INSTRUCTIONS

SIDEBARS

06-11 MERCEDES BENZ ML SERIES

PART# 200002/200002-2

PARTS LIST:

1	Driver/Left Sidebar	4	12mm x 24mm OD x 2.5mm Flat Washers
1	Passenger/Right Sidebar	4	12mm Lock Washers
2	Front Mounting Brackets (tall)	2	12mm Coupling Hex Nut (front)
2	Rear Mounting Brackets (short)	2	12mm Hex Nut (rear)
2	12-1.75mm x 90mm Long Bolt Plate (front)	8	10-1.50mm x 30mm Hex Bolts
2	12-1.75mm x 70mm Bolt Plate (rear)	16	10mm x 20mm OD x 1.5mm Flat Washers
4	12mm Plastic Retainers	8	10mm Nylon Lock Nuts

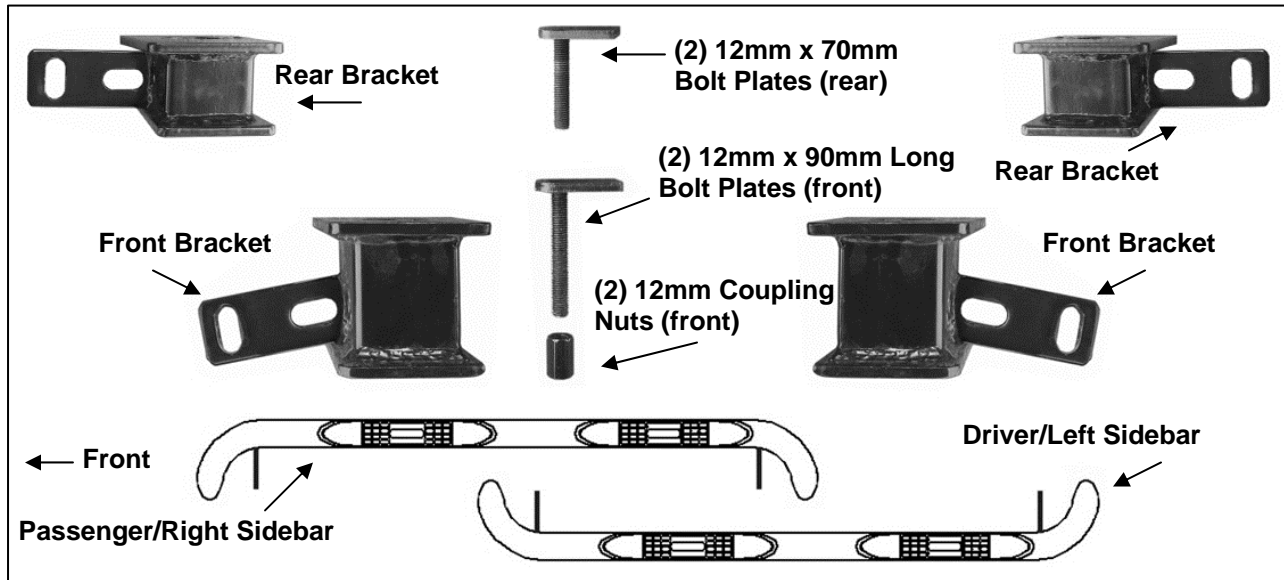

PROCEDURE:

- 1. REMOVE CONTENTS FROM BOX. VERIFY ALL PARTS ARE PRESENT. READ INSTRUCTIONS CAREFULLY.**
- Start installation from under the driver side of the vehicle. Remove the plastic plug in the center of the jack pad. **NOTE:** Depending on the year and model of vehicle, either unscrew the plug, (**Figure 1A**), or pry the plug out of the center of the jack pad, (**Figure 1B**). Once the plug has been removed, remove the jack pad, (**Figure 1B**).
- Insert (1) 12mm x 90mm Long Bolt Plate into the factory hole once the jack pad has been removed, (**Figure 2**).
- Select (1) Front Mounting Bracket, (**Figure 3**). Secure the front Mounting Bracket to the Bolt Plate with (1) 12mm Lock Washer, (1) 12mm Flat Washer and (1) 12mm Coupling (long) Hex Nut, (**Figure 4**). Do not tighten hardware at this time. **NOTE:** Refer to **Figure 3** to help identify brackets.
- Move toward the rear of the driver side and repeat **Step 2** to remove the driver side rear jack pad.
- Insert (1) 12mm x 70mm Bolt Plate into the factory opening in the floor panel. Secure the driver side Rear Mounting Bracket with (1) 12mm Flat Washer, (1) 12mm Lock Washer and (1) 12mm Hex Nut as described in **Step 4**, (**Figure 5**).
- Select the Driver Sidebar and loosely attach it to the Mounting Brackets with the included (4) 10mm x 30mm Hex Bolts, (8) 10mm Flat Washers and (4) 10mm Nylon Lock Nuts, (**Figure 6**).
- Level and adjust the Sidebar and tighten all hardware at this time.
- Repeat **Steps 2 - 8** for passenger Sidebar installation.
- Do periodic inspections to the installation to make sure that all hardware is secure and tight.

To protect your investment, wax this product after installing. Regular waxing is recommended to add a protective layer over the finish. Do not use any type of polish or wax that may contain abrasives that could damage the finish.

For stainless steel: Aluminum polish may be used to polish small scratches and scuffs on the finish. Mild soap may be used also to clean the Sidebar.

For gloss black finishes: Mild soap may be used to clean the Sidebar.

Driver Side Installation Pictured

Models with threaded plugs: Remove-unscrew factory plastic plug (center) and outer jack pad...

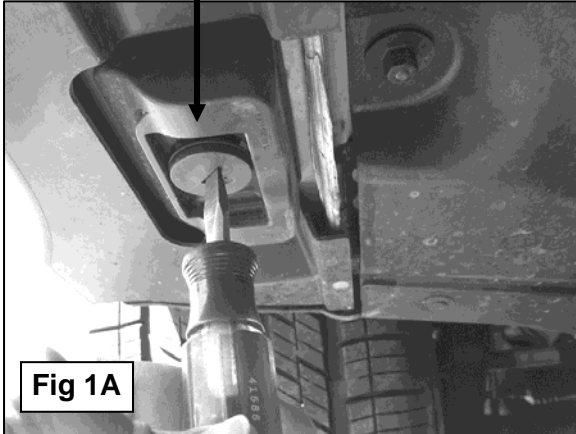

...or use a small screwdriver to pry up the push in factory plastic plug (center) and outer jack pad

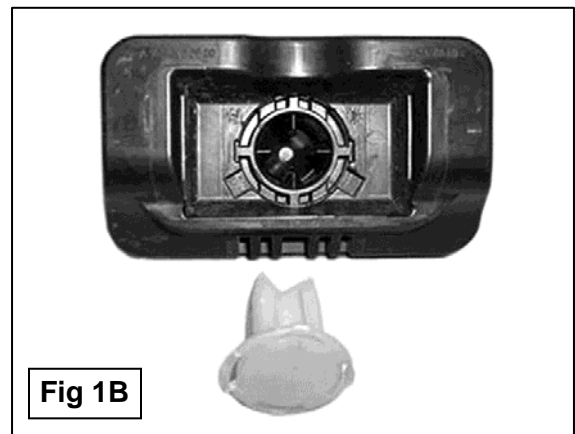

12mm x 90mm Long Bolt Plate (front bracket pictured)



Rear Bracket with Hardware

Front Bracket with Hardware

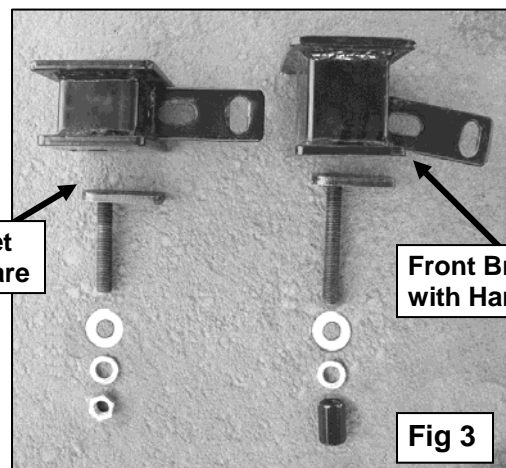

Driver Side Installation Pictured

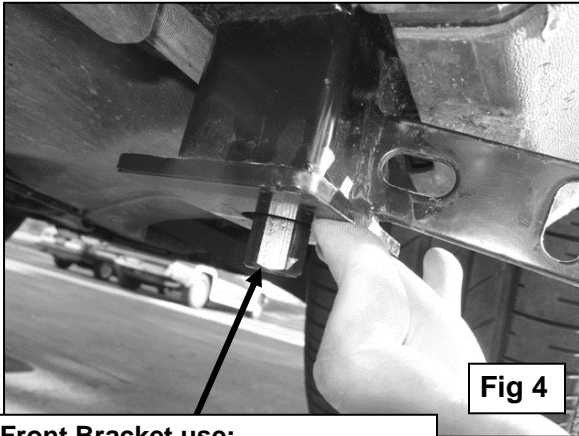

Fig 4

Front Bracket use:
12mm x 90mm Long Bolt Plate
12mm Flat Washer
12mm Lock Washer
12mm Long Coupling Hex Nut



Fig 5

Rear Bracket use:
12mm x 70mm Bolt Plate
12mm Flat Washer
12mm Lock Washer
12mm Regular Hex Nut

(2) 10mm x 30mm Hex Bolts
(4) 10mm Flat Washers
(2) 10mm Nylon Lock Nuts

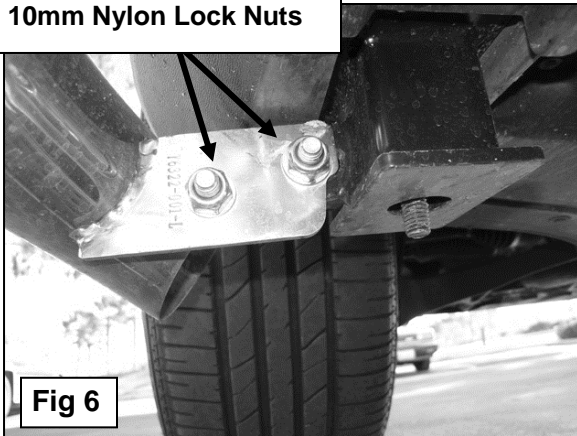

Fig 6



Installation Complete