

### Parts List

1	Driver / left running board
1	Passenger / right running board
2	Mounting bracket, front
2	Mounting bracket, middle
2	Mounting bracket, rear
2	Connector bracket, front
2	Connector bracket, middle
2	Connector bracket, rear
2	Brace bracket, middle
2	Riv-nut applicator
2	T-bolt, 40mm tab
2	T-bolt, 71mm tab
2	T-bolt, 98mm tab
4	Hex bolt, 10mm
14	Flat washer, 10mm
10	Lock washer, 10mm
10	Hex nut, 10mm
10	Round head bolt, 8mm
4	Hex bolt, 8mm
4	Flat washer, 8mm
14	Lock washer, 8mm
10	Hex nut, 8mm
4	Riveted nut
6	Bolt retainer, plastic

### Additional Hardware\*

12	Hex bolt, 8mm
12	Flat washer, 8mm
12	Lock washer, 8mm
12	Hex nut, 8mm

\* Running boards are supplied with additional hardware. Quantities listed are in addition to the standard supplied hardware.

### Level of Difficulty

Easy



Scan for helpful install tips

### Product Image

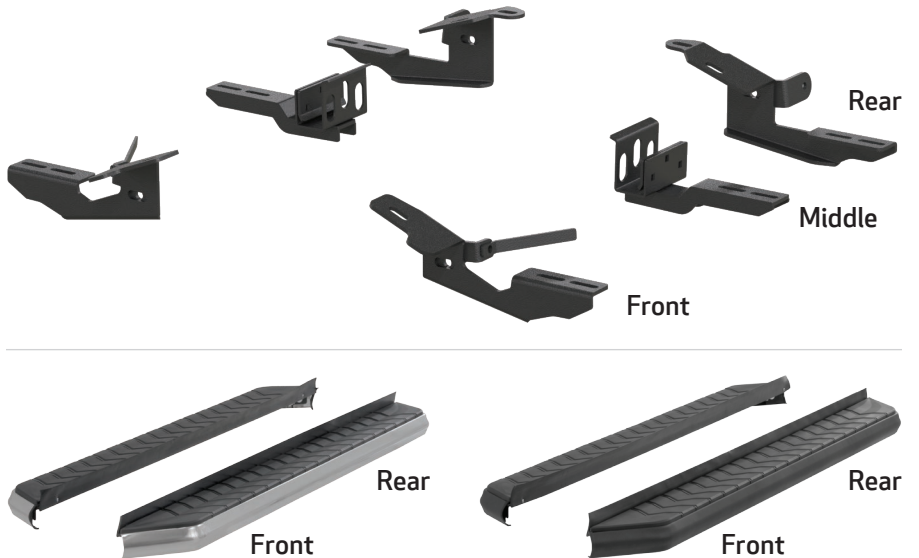

### Notes and Maintenance

Before you begin installation, read all instructions thoroughly.

Proper tools will improve the quality of installation and reduce the time required.

For stainless steel, polish may be used to clear small scratches and scuffs on the finish. Mild soap may be used also to clean the product.

For black finishes, mild soap may be used to clean the product.

### Tools Required

Ratchet	Socket, 13mm
Level	Socket, 16mm
Extension	

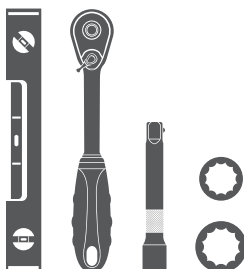

### Step 1

Starting on the driver side, locate the three mounting locations underneath the vehicle. Locate the front bracket for the driver side front mounting location.



### Step 2

Insert a 40mm T-bolt plate into the opening. Slide a plastic bolt retainer over the thread of the bolt to hold the bolt in place.

Place the front driver side bracket onto the vehicle and secure with a 10mm hex nut, lock washer and flat washer.

Insert a 10mm hex bolt and flat washer through the side hole on the connector bracket and mounting bracket.

Secure the connector bracket to the mounting bracket using a 10mm flat washer, lock washer and hex nut.



T-bolt

Mark hole location

### Step 3

With the front bracket connector bolted to the front mounting bracket, make a mark in the hole where the connector bracket meets the vehicle.

Remove the connector bracket and drill a 7/16" a hole to accept an 8mm rivet nut. We recommend the use of a professional thread-setting tool to compress the rivet nut into the drilled hole. If you do not have a thread-setting tool, a manual thread-set bar may be used.

To use a manual bar, thread an 8mm bolt and flat washer through the thread-set bar and into the 8mm rev nut. With the rev nut pressed into the drilled hole, apply leverage to the bar while tightening the bolt to compress the nut. With the nut compressed into the hole, remove the bolt, washer and leverage bar.

With the rev nut installed, secure the connector bracket to the vehicle using an 8mm hex bolt, lock washer and flat washer. Snug the hardware, but do not fully tighten.

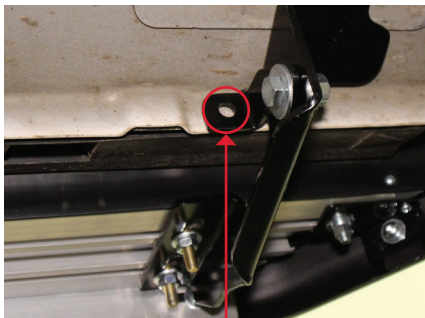

Drill 7/16" hole for 8mm rev nut

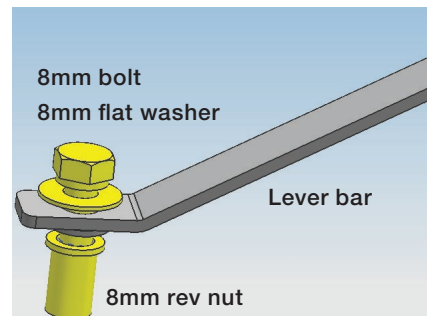

8mm bolt  
8mm flat washer

Lever bar

8mm rev nut

#### Step 4

Locate the middle mounting bracket and mounting location. Attach the middle mounting bracket to the middle bracket connector using two 8mm round head bolts, flat washers, lock washers and hex nuts.

Attach the middle brace bracket to the connector bracket by inserting an 8mm round head bolt and flat washer in through the bracket. Secure with an 8mm flat washer, lock washer and hex nut in the two lower mounting holes.

Place the middle driver side bracket onto the vehicle. Make a mark in the third hole where the brace bracket meets the vehicle. Drill a 7/16 hole at the marked location and finish securing the bracket using an 8mm round head bolt and flat washer through the bracket and hole. Secure with an 8mm flat washer, lock washer and hex nut through the center cutout on the inside support bracket.

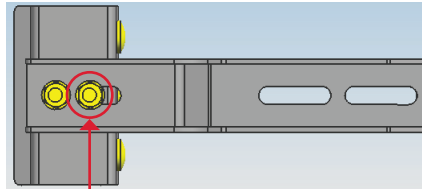

8mm round head bolt  
8mm flat washer  
8 spring washer  
8mm hex nut

Connector 3

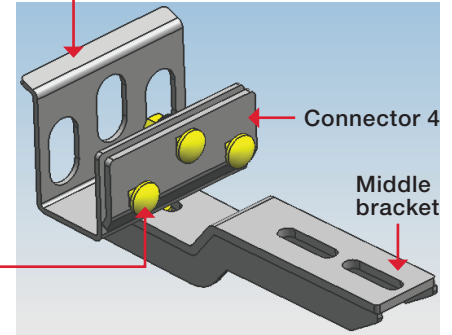

#### Step 5

Locate the rear mounting bracket and mounting location. Insert a 71mm T-bolt plate into the rear mounting point and a 98mm T-bolt plate into the remaining mounting hole. Slide plastic bolt retainers over the threads of the bolts to hold them in place.

Place the rear driver side bracket onto the vehicle and secure with a 10mm hex nut, lock washer and flat washer on each T-bolt. Place the rear bracket connector up to the vehicle. Make a mark in the hole where the connector bracket meets the vehicle.

Drill a 7/16" hole at the mark and insert a riv nut into the drilled hole. Follow the procedures listed in step 2 to compress the revnut. Secure the connector bracket to the vehicle using an 8mm hex bolt, lock washer, flat washer and hex nut. Snug the hardware, but do not fully tighten.

Secure the connector bracket to the mounting bracket using a 10mm hex bolt, lock washer, flat washer and hex nut.



Mark and drill 7/16"  
Install 8mm revnut

## Step 6

Remove the 8mm nuts, lock washers and flat washers from the running board.

Place the running board onto the brackets and align the 8mm bolts with the slots in the brackets on the vehicle.

Attach the running board to the brackets using six 8mm bolts, lock washers, flat washers and nuts.

Snug the hardware, but do not fully tighten.

Adjust and level the running board, centering it between the front and rear wheel wells.

With the running board in position, it is recommended to tighten all brackets to the vehicle first, followed by the running board connections.



## Step 7

Repeat steps 1 through 6 on the passenger side of the vehicle.

Congratulations on the installation of your brand new ARIES AeroTread™ running boards.

With the running boards installed, periodic inspections should be performed to ensure all mounting hardware remains tight.

To protect your investment, see the 'Notes and Maintenance' section on the first page of this instruction manual.

