

INSTALLATION INSTRUCTIONS
35-2007 BULL BAR
08-10 TOYOTA HIGHLANDER (GAS & HYBRID)
PART NUMBER

PARTS LIST:

1	Bull Bar	2	12-1.75mm x 35mm Hex Head Bolts
1	Driver/Left Mounting Bracket	2	12-1.75mm x 30mm Hex Head Bolts
1	Passenger/Right Mounting Bracket	2	12mm Lock Washers
1	Driver/Left Lower Support Bracket	2	12-1.75mm x 90mm Bolt Plate
1	Passenger/Right Lower Support Bracket	4	12mm Nylock Nuts
		8	12mm ID x 32mm OD x 3mm Flat Washers
		2	10-1.25mm x 35mm Hex Head Bolts
		2	10mm ID x 26mm OD x 3mm Flat Washers

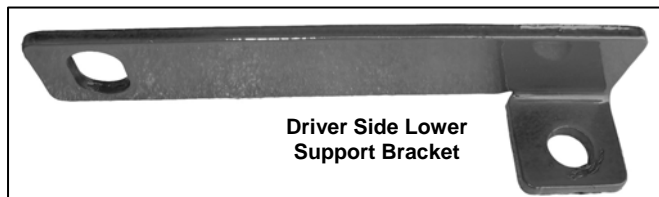

PROCEDURE:

- 1. REMOVE CONTENTS FROM BOX. VERIFY ALL PARTS ARE PRESENT. READ INSTRUCTIONS CAREFULLY BEFORE STARTING INSTALLATION. CUTTING REQUIRED**
2. From underside of vehicle, remove the front plastic splash guard, then place it on a clean working area.
3. On top of the cross member bar there is a factory suspension dampener obstructing one of the mounting locations for the Support Brackets. **NOTE:** The suspension dampener is located on the driver side for gas models (**Figure 2**) and on the passenger side for hybrid models (**Figure 1**). Use a 10mm socket to remove the two factory bolts holding the suspension dampener from the top of cross member.
4. Once you have removed the suspension dampener, start on the driver side of the vehicle to insert from the top of the cross member (1) 12mm x 90mm Bolt Plate (**Figure 3**). Gas Models: Re-install the suspension dampener over Bolt Plate using the factory hardware at this time. **NOTE:** On hybrid models the shifter arm and the shifter cable obstructs the installation of the Bolt Plate. In order to insert the Bolt Plate through the top of the cross member, first make sure that the vehicle is on a level surface, put the emergency brake on, then secure the vehicle by putting blocks on the tires to prevent it from rolling. Turn engine on and shift it to "B" then turn engine off. Insert Bolt Plate then turn engine back on and shift it to park then turn engine off.
5. On the driver side of the vehicle, locate the two factory bolts on the cross member brace towards the bumper and remove the one towards the outside of the vehicle. Position the driver side Mounting Bracket up to the cross member brace. Partially hang Mounting Bracket to previously removed factory bolt location using the included (1) 10-1.25mm x 35mm Hex Head Bolt and (1) 10mm Flat washer (**Figure 4**). Do not tighten at this time.
6. Repeat steps 3 & 5 for passenger side. **NOTE:** Hybrid Models: Re-install the suspension dampener right after you insert the Bolt Plate from the top.
7. Once you have partially mounted driver and passenger side Brackets. Position factory plastic rocker guard back to its mounting location and trace the outside on the Mounting Bracket and the mounting location of the Bolt Plates. Use a sharp knife to cut out the trace area for the Mounting Brackets and use a drill with a ½" drill bit to drill out the mounting location for the Bolt Plates on both sides (**Figure 5**).
8. Re-install the rock guard back to the bottom of the vehicle over Mounting Brackets.
9. From the bottom of the cross member bar, place Lower Support Bracket over previously inserted Bolt Plate and secure it using the included (1) 12mm Nylock Nut and (1) 12mm x 29mm x 3mm Flat Washer (**Figure 6**). Do not tighten at this time.
10. Attach opposite end of Lower Support Bracket to the inside of Mounting Bracket using the included (1) 12mm x 30mm Hex Head Bolt, (1) 12mm Nylock Nut, and (2) 12mm Flat Washers (**Figure 6**). Do not tighten at this time.
11. Repeat steps 8 & 9 for passenger side.
12. With help position Bull Bar onto Mounting Brackets. Attach Bull Bar to Mounting Brackets using the included (2) 12mm x 35mm Hex Head Bolts, (2) 12mm Lock Washers, and (2) 12mm Flat Washers (**Figure 7**).
13. Level and adjust Bull Bar properly; and then tighten all hardware at this time
14. Do periodic inspections to the installation to make sure that all hardware is secure and tight.

Hybrid Models: The Suspension dampener is located on the left side of the front cross member



Fig 1

Gas Models: The Suspension dampener is located on the right side of the front cross member

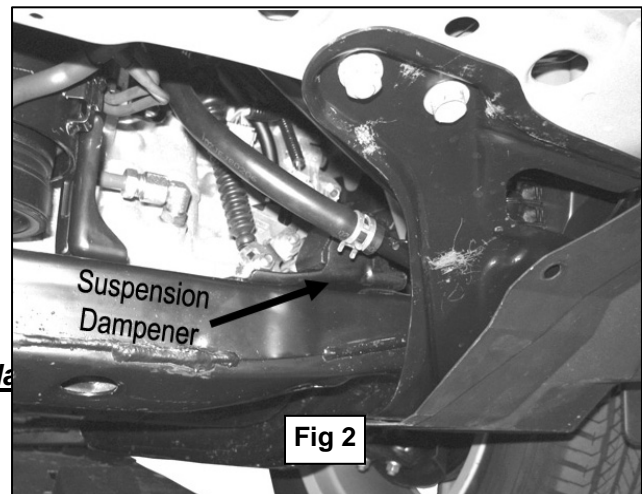

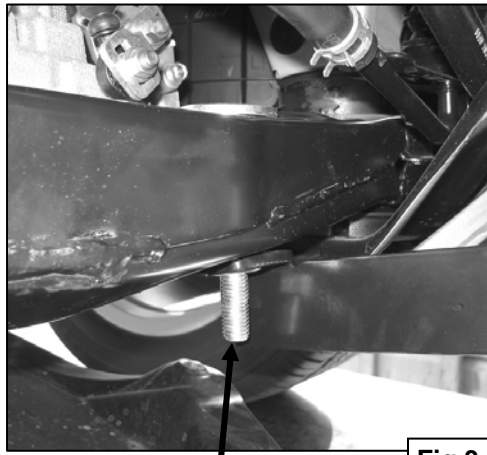

Fig 3

12mm x 90mm Bolt Plate

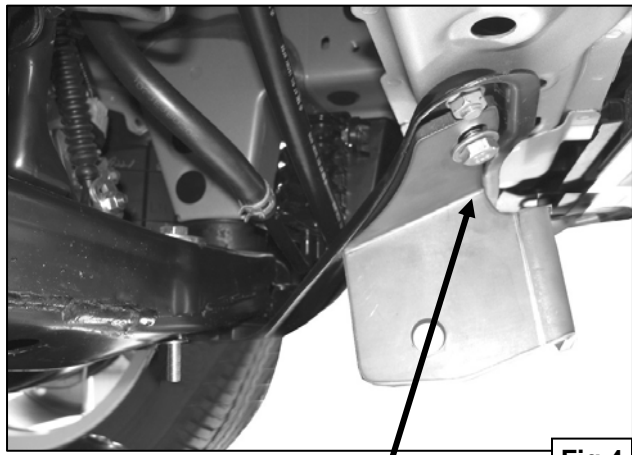

Fig 4

**Replace outer factory bolt with
10-1.25 x 35mm Hex Bolt
10mm Flat Washer**

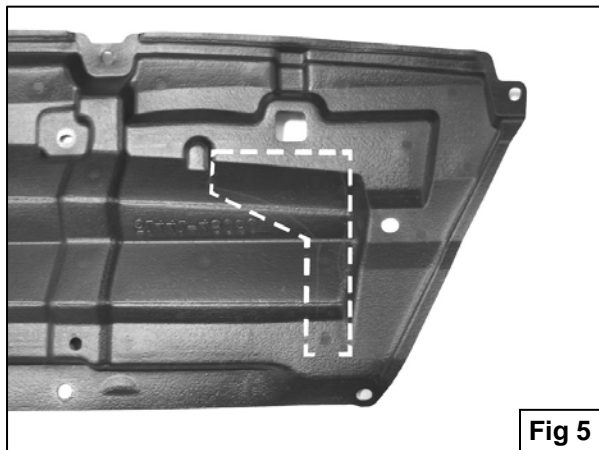

Fig 5

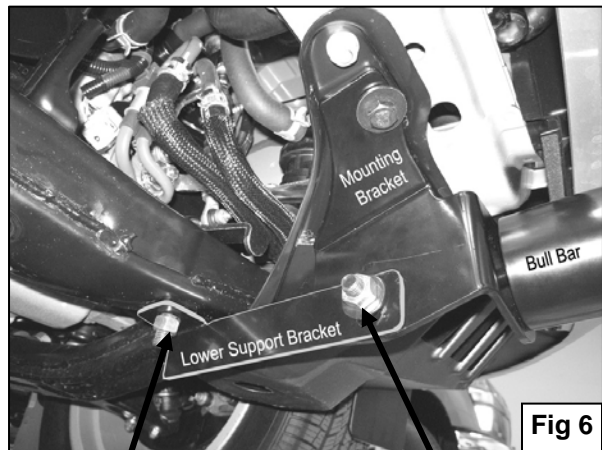

Fig 6

**(12mm x 90mm Bolt Plate)
12mm Nylock Nut
12mm Flat Washer**

**12mm x 30mm Hex Bolt
12mm Flat Washers
12mm Nylock Nut**

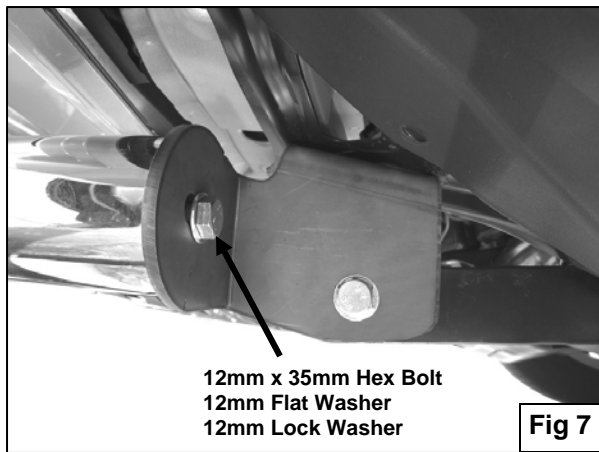

Fig 7

**12mm x 35mm Hex Bolt
12mm Flat Washer
12mm Lock Washer**



Fig 8