

INSTALLATION INSTRUCTIONS

BULL BAR

04-10 CHEVY COLORADO / GMC CANYON 2x4

PART NUMBER 35-4004

PARTS LIST:

1	Bull Bar	4	12mm Lock Washers
1	Driver/Left Mounting Bracket	10	12mm Flat Washers
1	Passenger/Right Mounting Bracket	4	12mm Hex Nuts
4	12 – 1.75mm x 100mm Hex Head Bolts	4	12MM Fender Washers (Spacer Washer)
2	12 – 1.75mm x 50mm Hex Head Bolts	2	Plastic Retainers
		2	12mm T-bolts (used for 09-10 L2)

PROCEDURE:

- 1. REMOVE CONTENTS FROM BOX. VERIFY ALL PARTS ARE PRESENT. READ INSTRUCTIONS CAREFULLY BEFORE STARTING INSTALLATION.**
- 2. NOTE:** It may be necessary to remove/relocate front license plate and license plate bracket. It is not required, but strongly recommended. If local/state law requires a license plate, license plate relocation kit is available.
3. Remove lower valance by removing two pushpins from each side of the lower bumper. Using a flat tip screwdriver, pry the tabs out from the valance and remove. **NOTE:** If the lower valance is to be installed, it will need to be trimmed to fit the Bull Bar.
4. Determine right/passenger and left/driver Mounting Brackets. Position right/passenger Mounting Bracket to the inside of the frame rail. From the outer side of frame, insert (2) 12mm x 100mm Hex Head Bolts with (2) Spacer Washers and secure them with (2) 12mm Lock Washers, (2) 12mm Flat Washers, and (2) 12mm Hex Nuts as shown in figure 1 below. Do not tighten at this time. Repeat this step for opposite side Mounting Bracket.

2009-2010 L2 MODELS (ONLY)

- 5. Determine right/passenger and left/driver Mounting Brackets. Position right/passenger Mounting Bracket to the inside of the frame rail. For the front hole, from the outer side of frame, insert (1) 12mm x 100mm Hex Head Bolt with (1) Spacer Washer and secure them with (1) 12mm Lock Washers, (1) 12mm Flat Washer, and (1) 12mm Hex Nut. For the rear hole insert T-bolt (input at slight angle) into inner hole on of frame rail, using the plastic retainer to hold in place. Secure them with (1) 12mm Lock Washer, (1) 12mm Flat Washer, and (1) 12mm Hex Nut.**
6. Do not tighten at this time. Repeat this step for opposite side Mounting Bracket.
7. Carefully position Bull Bar onto Mounting Brackets. Attach Bull Bar to Mounting Brackets using the included (2) 12mm x 50mm Hex Head Bolts, (2) 12mm Lock Washers, and (2) 12mm Flat Washers as shown in figure below. Do not tighten at this time.

8. Adjust Bull Bar; then tighten all hardware at this time.
9. Do periodic inspections to the installation to make sure that all hardware is secure and tight.

Figure 1
04-08 L1 Models (09-10 L1 Models)

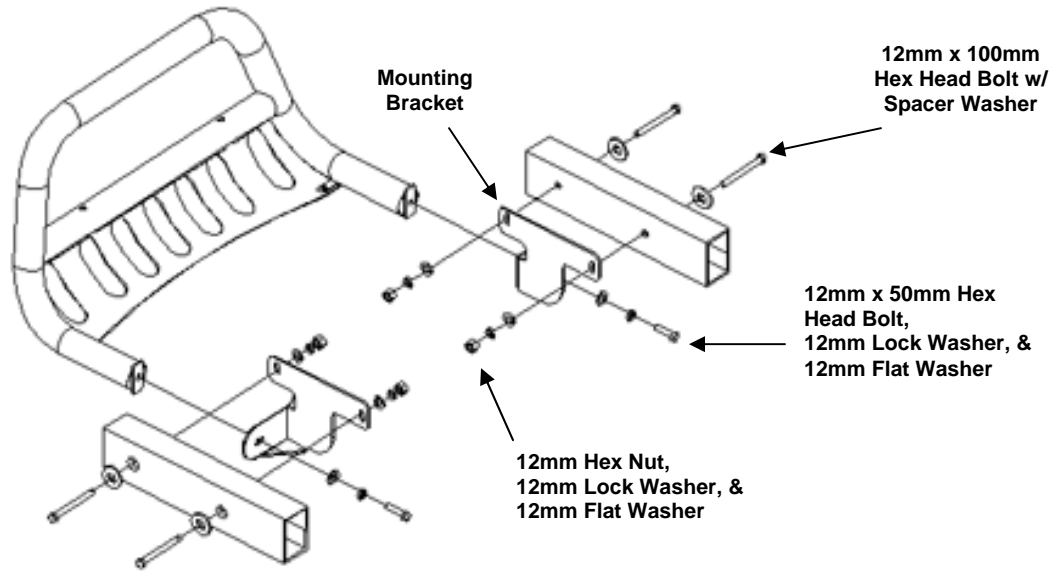
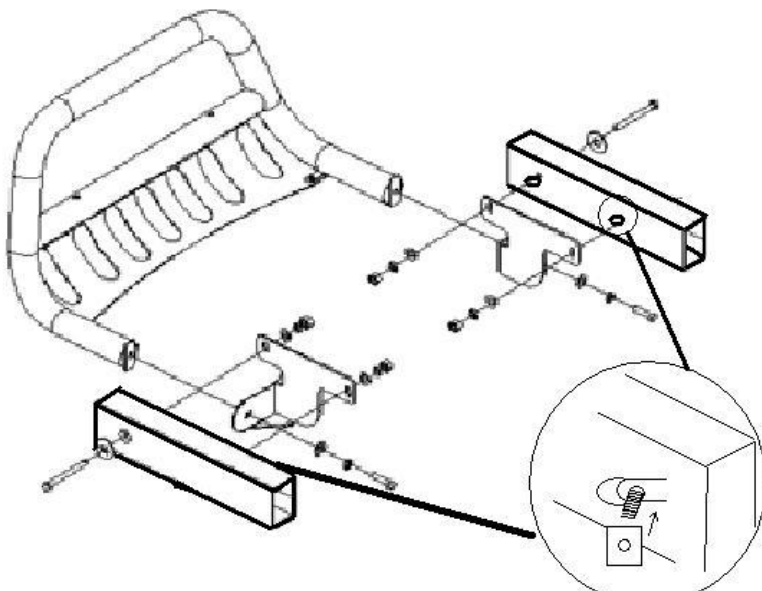

Figure 2
2009-up (L2 Models)



INSERT 12MM T-BOLT INTO HOLE. USE THE PLASTIC RETAINER PROVIDED TO HOLD IN PLACE WHILE ATTACHING BRACKET