



## INSTALLATION INSTRUCTIONS

2.5" BULL BAR PART # 35-5007/B35-5007  
2011 DODGE DURANGO

### PARTS LIST:

1	Bull Bar
1	Driver/Left Side Frame Mounting Bracket
1	Passenger/Right Side Frame Mounting Bracket
8	10-1.5mm x 35mm Hex Bolts
12	10mm x 30mm OD x 2.5mm Flat Washers
8	10mm Lock Washers
4	10mm Hex Nuts



Complete Installation

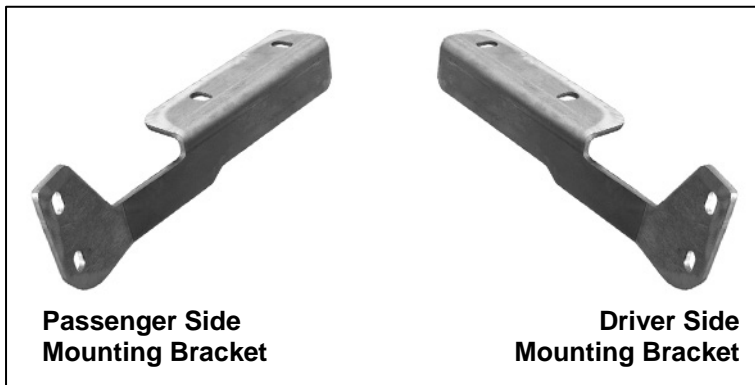

### PROCEDURE:

1. REMOVE CONTENTS FROM BOX. VERIFY ALL PARTS ARE PRESENT. READ INSTRUCTIONS CAREFULLY BEFORE STARTING INSTALLATION. ASSISTANCE IS RECOMMENDED.

**IMPORTANT:** This Bull Bar is not compatible with optional Adaptive Cruise Control-Forward Collision Warning Systems featuring grille mounted laser control sensor.

2. Determine if the vehicle is equipped with, **(Figure 1)** or without factory tow hooks, **(Figure 2)**. Remove the plastic splash guard, **(Figures 3 & 4)**. Pay close attention to the type and location of all factory hardware for easier reinstallation. If vehicle is equipped with tow hooks, remove both tow hooks and skip ahead to **Step 3**. **NOTE:** Tow hooks cannot be reinstalled with the Bull Bar.
  - a. **On vehicles without factory tow hooks:** Release the clips at the ends of the plastic bumper cover that attach the lower cover to the upper cover. **NOTE:** It is not necessary to remove the lower cover, only release the clips at the ends of the cover. Next, remove the (3) clips fastening the air deflector to the bottom of the crossmember, **(Figures 3 & 4)**. Pull the bumper cover forward for access and pull the air deflector out from behind the bumper cover, **(Figure 5)**. Release the clips securing the (2) block off covers to the ends of the air deflector, **(Figure 6)**. Remove the (2) block offs. Reinstall the air deflector using the factory hardware. Reinstall the bumper cover.
3. Select the driver side Frame Mounting Bracket. Line up the (2) slots in the bracket with the (2) threaded holes in the bottom of the frame channel, **(Figure 7)**. Bolt the Bracket to the frame channel with (2) 10mm x 35mm Hex Bolts, (2) 10mm Flat Washers and (2) 10mm Lock Washers, **(Figure 8)**. Do not tighten hardware at this time. Repeat this step for passenger side Frame Bracket installation.

4. With assistance, hold the Bull Bar up to the outside of the Mounting Brackets. Attach the Bull Bar to the Mounting Brackets with the included (4) 10mm x 35mm Hex Bolts, (8) 10mm Flat Washers, (4) 10mm Lock Washers and (4) 10mm Hex Nuts, **(Figure 9)**.
5. Align and adjust the Bull Bar and tighten all hardware. Reinstall the splash guard removed in Step 3, **(Figures 3 & 4)**.
6. Do periodic inspections to the installation to make sure that all hardware is secure and tight.

**To protect your investment**, wax this product after installing. Regular waxing is recommended to add a protective layer over the finish. Do not use any type of polish or wax that may contain abrasives that could damage the finish.

**For stainless steel:** Aluminum polish may be used to polish small scratches and scuffs on the finish. Mild soap may be used also to clean the Bull Bar.

**For gloss black finishes:** Mild soap may be used to clean the Bull Bar.

### Driver Side Installation Pictured

Passenger side tow hook

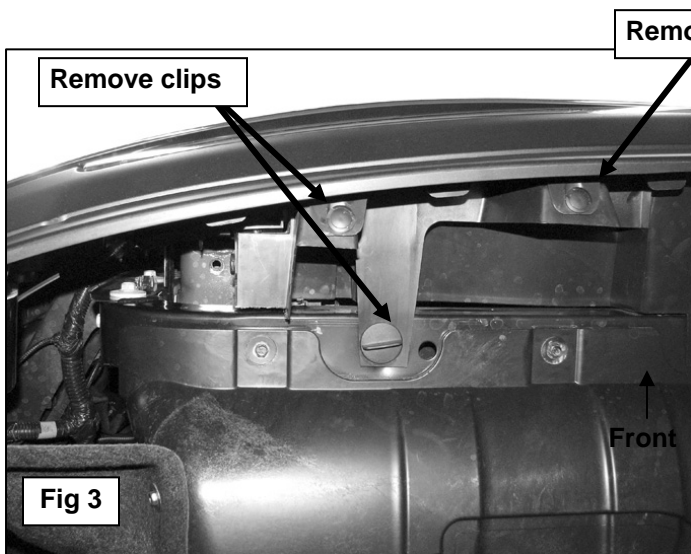
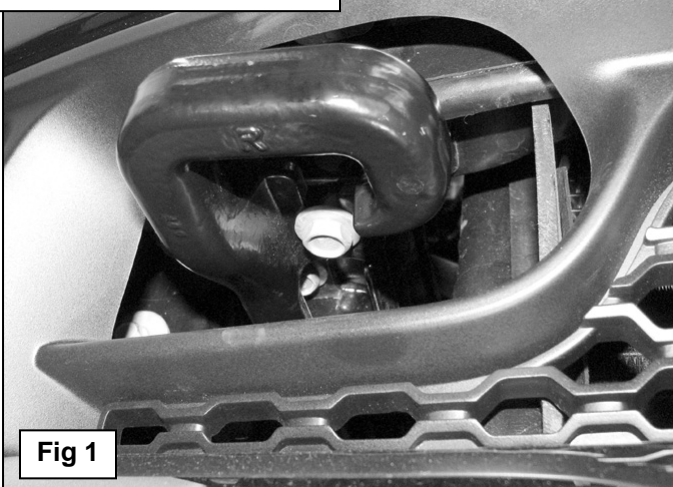

Remove splash guard (passenger side pictured from below)

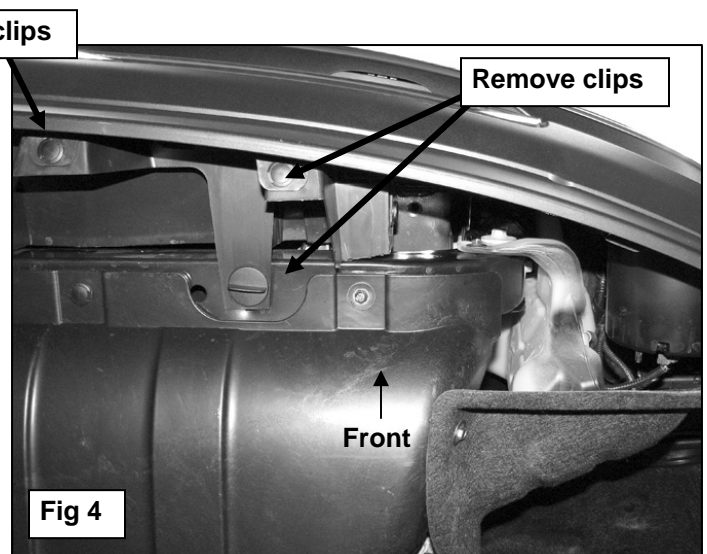

Remove splash guard (driver side pictured from below)

## Driver Side Installation Pictured

