

INSTALLATION INSTRUCTIONS

2007-13 FORD EDGE
EXCLUDES SPORT MODEL
PART # 3502

PARTS LIST:

| | | | |
|---|----------------------------------|----|-------------------------------------|
| 1 | Sport Bar | 8 | 12-1.75mm x 35mm Hex Bolts |
| 1 | Driver/Left Mounting Bracket | 4 | 12mm Lock Washers |
| 1 | Passenger/Right Mounting Bracket | 12 | 12mm x 32mm OD x 3mm Flat Washers |
| 1 | Driver/Left Support Bracket | 4 | 12mm Nylon Lock Nuts |
| 1 | Passenger/Right Support Bracket | 2 | 10-1.50mm x 30mm Hex Bolts |
| 2 | 12mm Double Nut Plates | 6 | 10mm x 30mm OD x 2.5mm Flat Washers |
| 2 | 10-1.50mm x 30mm Bolt Plates | 4 | 10mm Nylon Lock Nuts |

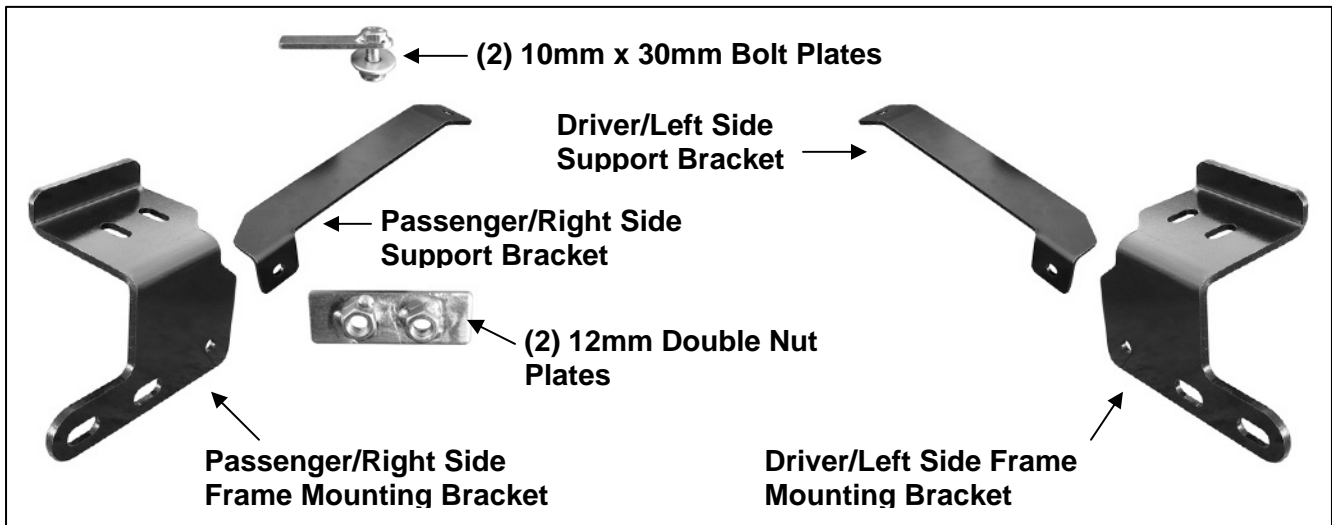

PROCEDURE:

1. REMOVE CONTENTS FROM BOX. VERIFY ALL PARTS ARE PRESENT. READ INSTRUCTIONS CAREFULLY BEFORE STARTING INSTALLATION. CUTTING IS REQUIRED.
2. Start installation under the front of the vehicle. Remove the plastic splash guard attached to the bottom of the front bumper cover.
3. Insert (1) Double Nut Plate into the opening in the front of the frame on the passenger side, **(Figures 1 & 2)**. Line up the (2) holes in the Double Nut Plate with the factory holes in the frame, **(Figure 3)**.
4. Select the passenger side Frame Mounting Bracket. Hold the Mounting Bracket in position and secure it by threading (2) 12-1.75mm x 35mm Hex Bolts, (2) 12mm Lock Washers, and (2) 12mm Flat Washers through the holes in the Bracket, frame and into the Double Nut Plate, **(Figure 4)**. Do not tighten hardware at this time. Repeat **Steps 3 & 4** for driver side Frame Mounting Bracket installation.
5. Select the passenger side Support Bracket and attach it to rear hole on the Mounting Bracket using the included (1) 10-1.50mm x 30mm Hex Bolt, (2) 10mm Flat Washers and (1) 10mm Nylon Lock Nut, **(Figures 4 & 6)**. Do not tighten at this time.
6. Insert (1) Bolt Plate into factory hole in the frame, **(Figure 5)**. Line up the remaining hole in the Support Bracket with the previously installed Bolt Plate. Attach the Support Bracket to the Bolt Plate with the included (1) 10mm Flat Washer and (1) 10mm Nylon Lock Nut, **(Figure 6)**. Do not tighten hardware at this time.

7. Repeat **Steps 5 & 6** for driver side Support Bracket installation. Tighten all Mounting Bracket and Support Bracket hardware at this time.
 - a. **2007-10 model vehicles:** The factory lower spoiler must be removed or (2) slots cut to clear the tabs on the Sport Bar. If you choose to retain the spoiler, mark the Bracket location onto the back of the spoiler, (**Figure 7**). Remove the spoiler and place it on a clean, stable work surface. Cut (2) openings with a sharp knife or hacksaw. Only remove enough material to clear the mounting tab on the Sport Bar. Do not reinstall the spoiler at this time.
 - b. **2011 model vehicles:** (2) slots must be cut into the spoiler for the Sport Bar mounting tabs. Mark the location onto the back of the spoiler and cut the opening with a sharp knife or hacksaw, (**Figure 7**). Do not cut through the top or bottom edge of the spoiler. Only remove enough material to clear the mounting tab on the Sport Bar. **IMPORTANT:** On 2011 vehicles, the spoiler is riveted to the bumper cover at each end and is not completely removable.
8. Hold the plastic splash guard, (see **Step 2**), up in the approximate mounting position and mark the location of the Mounting Brackets onto the splash guard, (**Figure 8A**). Place the splash guard on a clean stable work surface. Cut (2) slots in the splash guard to provide clearance for the Mounting Brackets, (**Figure 8B**). **IMPORTANT:** Do not cut through the front edge of the splash guard. Only cut material required to clear the Brackets. Reinstall the splash guard using the factory hardware.
 - a. **NOTE on 2011 models:** It may be necessary to move the spoiler a little to reinstall the splash guard. **IMPORTANT:** The spoiler is riveted at the ends to the bumper and cannot be removed completely; simply remove the hardware to move the spoiler. Once the splash guard is reinstalled, bolt the spoiler in place with the factory hardware.
9. With assistance, position the Sport Bar onto the outside of the Mounting Brackets. Attach the Sport Bar to the Mounting Brackets with (4) 12mm x 35mm Hex Bolts, (8) 12mm Flat Washers and (4) 12mm Nylon Lock Nuts, (**Figure 9**). Do not tighten at this time.
10. Level and adjust the Sport Bar and tighten all hardware at this time.
11. Do periodic inspections to the installation to make sure that all hardware is secure and tight.

To protect your investment, wax this product after installing. Regular waxing is recommended to add a protective layer over the finish. Do not use any type of polish or wax that may contain abrasives that could damage the finish.

For stainless steel: Aluminum polish may be used to polish small scratches and scuffs on the finish. Mild soap may be used also to clean the Sportbar.

For gloss black finishes: Mild soap may be used to clean the Sportbar.

Passenger Side installation Pictured

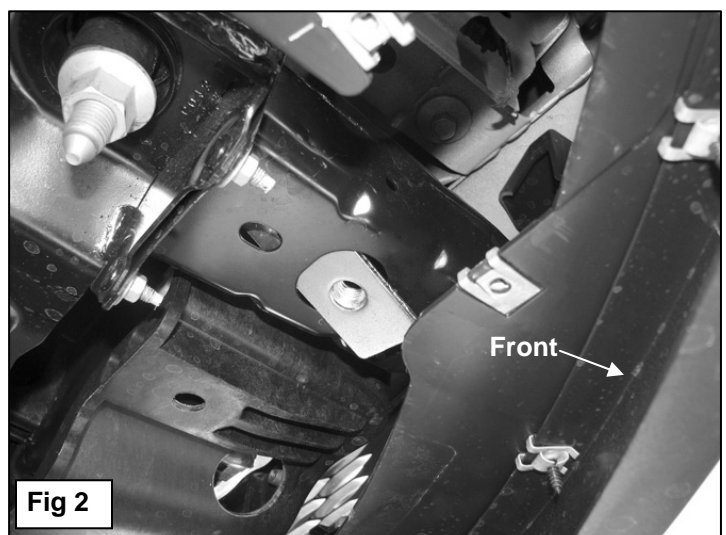
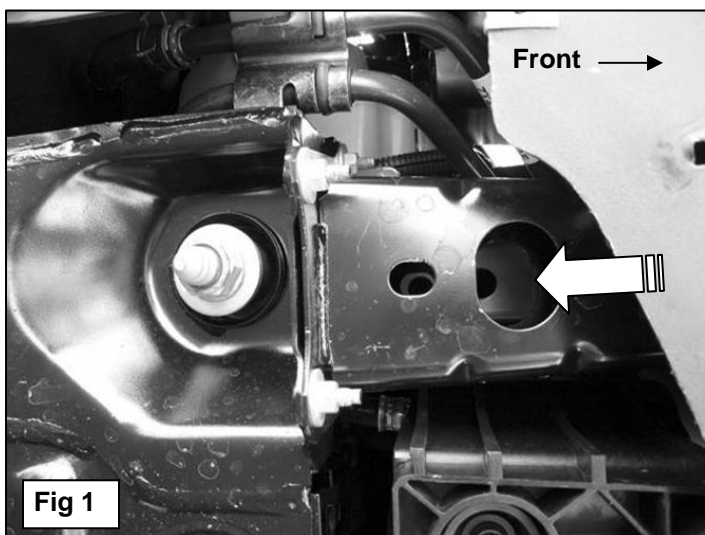

**Insert Double Nut Plate into opening
and line up with holes in frame**

Passenger Side installation Pictured

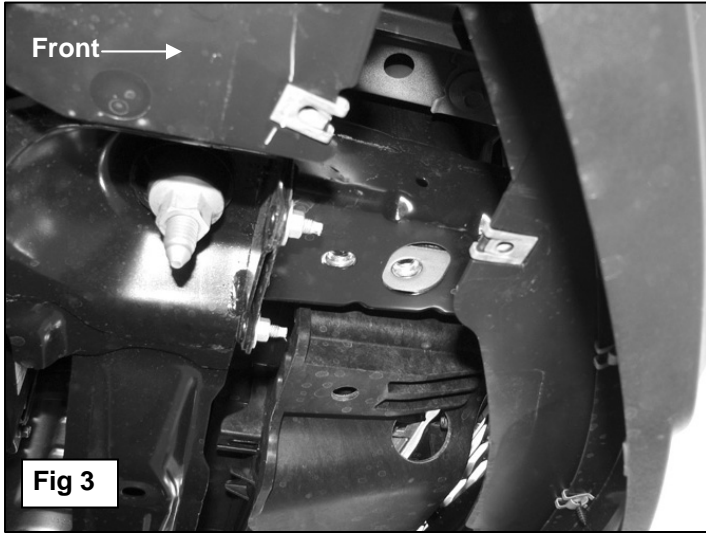

- (2) 12mm x 35mm Hex Bolts
- (2) 12mm Lock Washers
- (2) 12mm Flat Washers

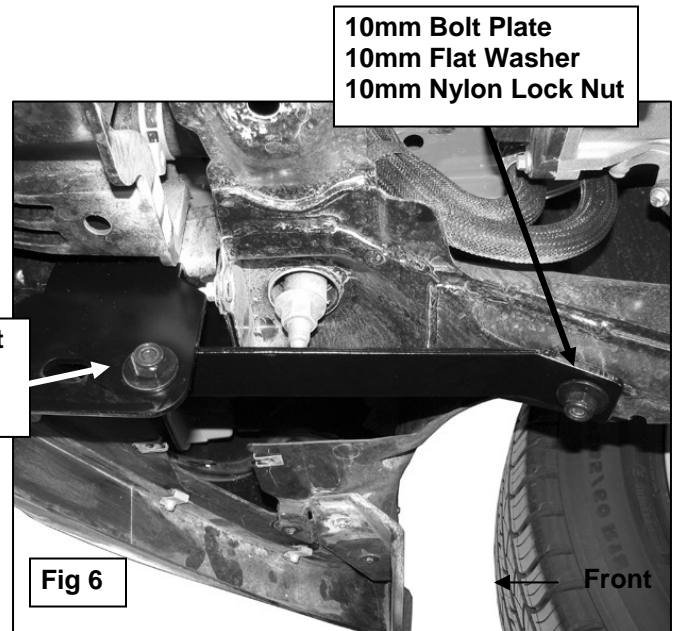
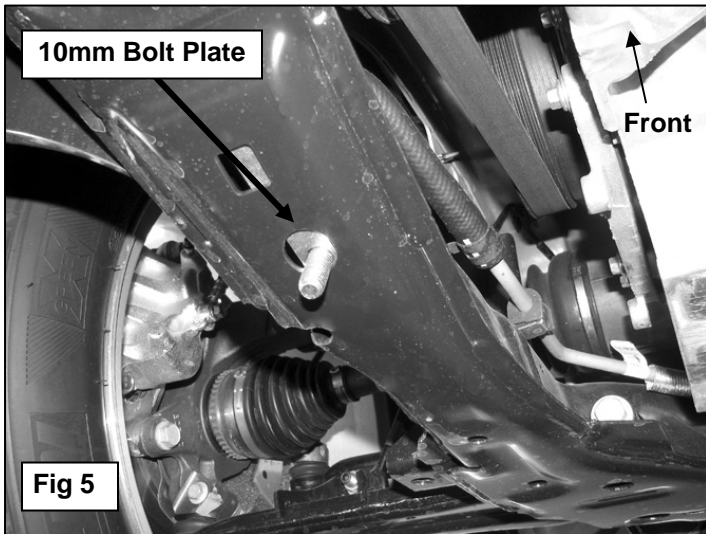
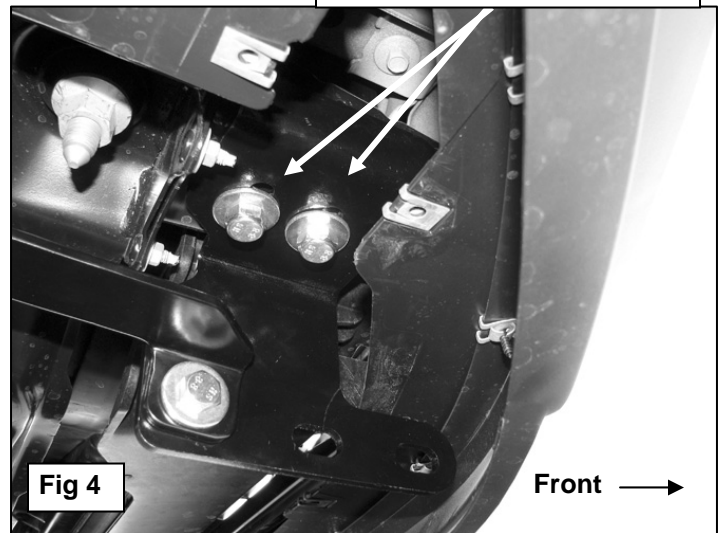

- 10mm x 30mm Hex Bolt
- (2) 10mm Flat Washers
- 10mm Nylon Lock Nut

Passenger Side installation Pictured

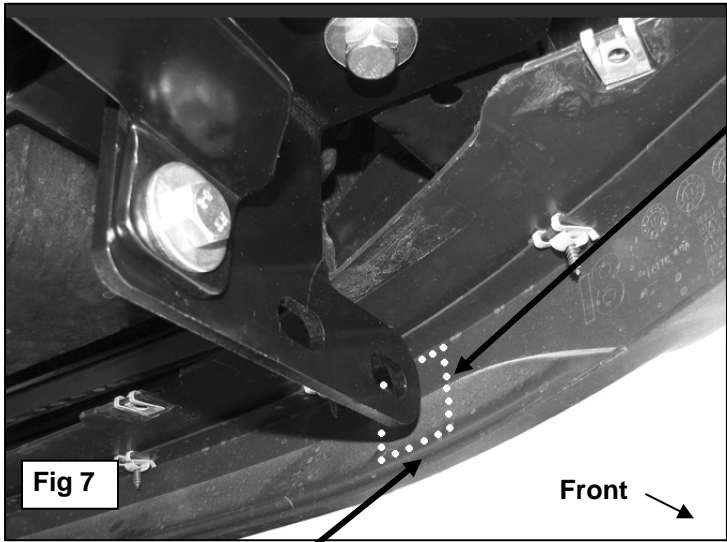

Trace bracket location onto back of spoiler and cut out to clear Sport Bar tabs

Cut as little as possible to tabs on Sport Bar. Do not cut through the top or bottom edge of spoiler

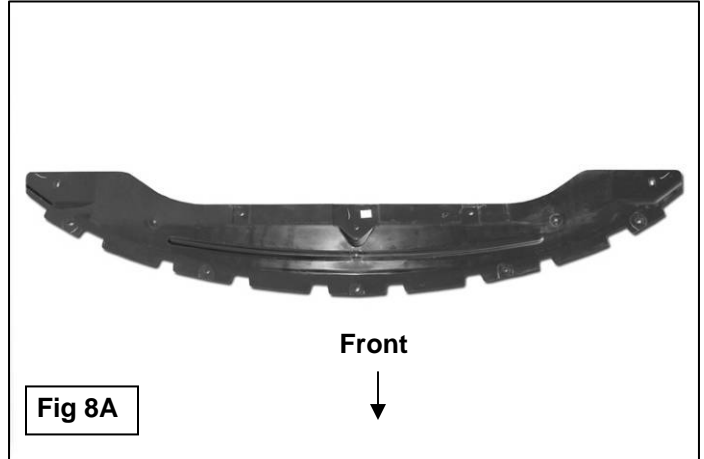

Cut as little as possible to clear brackets. Do not cut through the front edge of splash guard

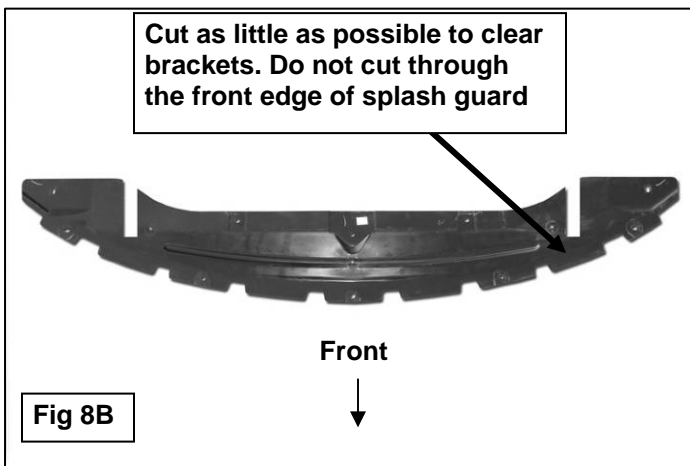

10mm x 30mm Hex Bolt
(2) 10mm Flat Washers
10mm Nylon Lock Nut

