

INSTALLATION INSTRUCTIONS

502701/502701-2

04-2008 MINI COOPER CONVERTIBLE

PARTS LIST:

Qty	Description	Qty	Description
1	Driver/Left Side Rail	4	10mm Hex Nuts
1	Passenger/Right Side Rail	4	10mm Lock Washers
1	Driver/Left Front Mounting Bracket	4	10mm Flat Washers
1	Passenger/Right Front Mounting Bracket	4	10mm x 25mm Bolt Plate
1	Driver/Left Middle Mounting Bracket	16	8mm Flat Washer
1	Passenger/Right Middle Mounting Bracket	8	8mm Hex Nuts with lock Washer
4	10mm Plastic Retainers	8	8mm x 20mm Bolt
2	12mm Flat Washers		

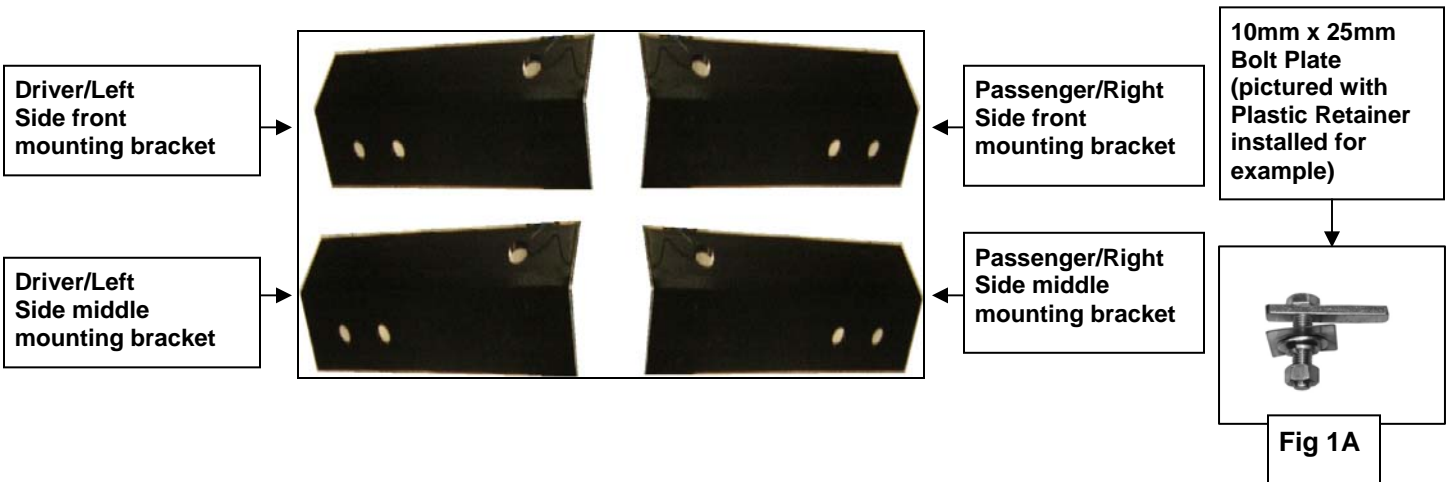
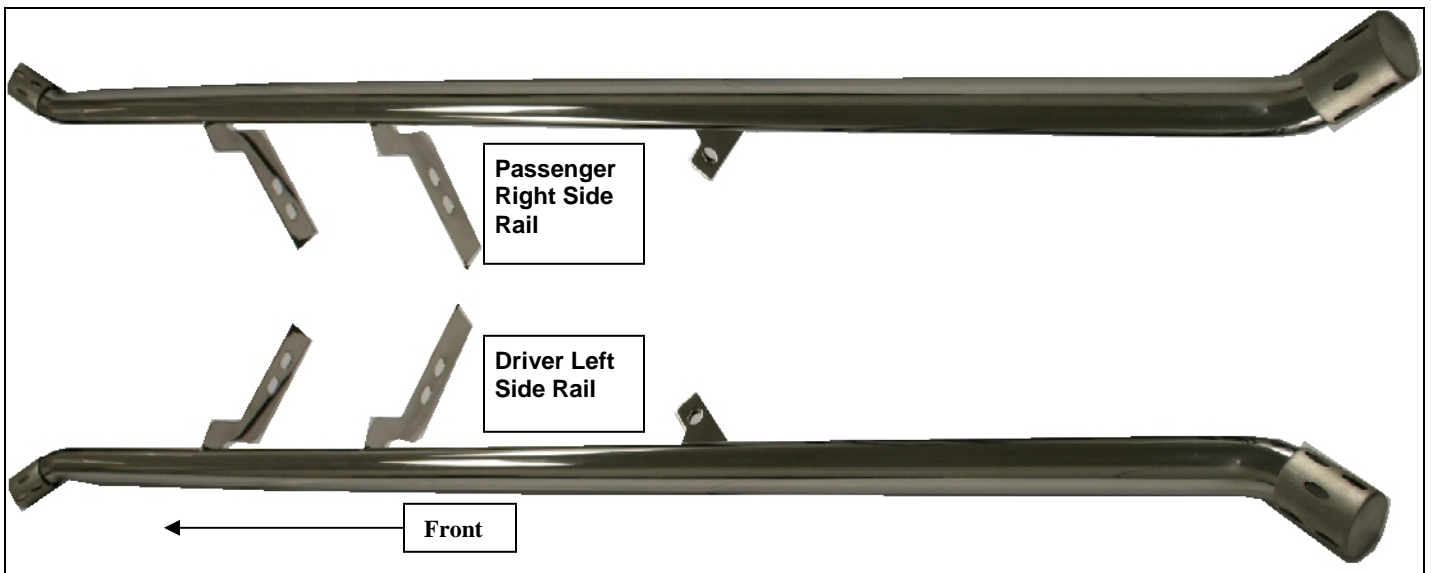

PROCEDURE:

1. **REMOVE CONTENTS FROM BOX. VERIFY ALL PARTS ARE PRESENT. READ INSTRUCTIONS CAREFULLY BEFORE STARTING INSTALLATION.**
2. Partially thread a Plastic Retainer onto each of the threaded ends of a Bolt Plate, **(Fig 1A)**
3. Once you have assembled the Plastic Retainer onto the Bolt Plates, Starting with the Driver/Left side, insert the Bolt Plate into each of the factory round holes **(Figure 1)**. Once the Bolt Plates are inserted, hold the Bolt end with one hand and tighten the Plastic Retainer with your other hand. **NOTE:** Tighten the Plastic Retainer until it reaches the floor panel.
4. Select the Driver/Left side front and middle Mounting Brackets. Position the Mounting Brackets onto the installed Bolt Plates. Secure each with (1) 10mm Flat Washers, (1) 10mm Lock Washers and (1) 10mm Hex Nuts, **(Figure 2)**. Snug but do not tighten hardware at this time.
5. Remove the one bolt securing the factory cross bar located on the Driver side/Left rear floor board **(Fig 3)**
6. Next, select the Driver/Left side Rail and fasten it to the Mounting Bracket with the included hardware, (4) 8mm Hex Head Bolt, (4) 8mm Hex nut lock washer, and (8) 8mm Flat Washer, Re install the factory bolt with the supplied 12mm flat washer securing the factory cross bar and the side rail **(Fig 4) and (Figure 2 & 4)** Shows side rail installed to brackets.
7. Level and align Side rail properly; then tighten all hardware at this time.
8. Repeat steps 3-7 for Passenger Side Rail.
9. Do periodic inspections to the installation to make sure all hardware is secure and tight.

To protect your investment, wax this product after installing. Regular waxing is recommended to add a protective layer over the finish. Do not use any type of polish or wax that may contain abrasives that could damage the finish.

For stainless steel: Aluminum polish may be used to polish small scratches and scuffs on the finish. Mild soap may be used also to clean the Sidebar.

For gloss black finishes: Mild soap may be used to clean the Sidebar.

DRIVER/LEFT SIDE INSTALLATION PICTURED

