

PARTS LIST:

1	Sport Bar	4	12mm Lock Washers
1	Driver/Left Frame Bracket	4	12mm Hex Nuts
1	Passenger/Right Frame Bracket	4	10-1.5mm x 80mm Hex Bolts
1	Driver/Left Support Bracket	4	10mm x 20mm OD x 2.5mm Flat Washers
1	Passenger/Right Support Bracket	4	10mm x 27mm OD x 3mm Flat Washers
2	12-1.75mm x 35mm Hex Bolts	4	10mm Lock Washers
2	12-1.75mm x 40mm Hex Bolts	4	10mm Hex Nuts
8	12mm x 32mm OD x 3mm Flat Washers		



PROCEDURE:

1. REMOVE CONTENTS FROM BOX. VERIFY ALL PARTS ARE PRESENT. READ INSTRUCTIONS CAREFULLY BEFORE STARTING INSTALLATION. ASSISTANCE IS RECOMMENDED. CUTTING IS REQUIRED.
2. Starting under the front of the vehicle, remove the plastic fasteners and hex bolts from the center splash guard, **(Figure 1)**. **NOTE:** Pay close attention to the type of clip and location for easier reinstallation. The center splash guard will need to be cut to clear the Mounting Brackets and removal is recommended. Note that the center splash guard has (2) fasteners behind the bumper cover, (one per side), that are difficult to remove, **(Figure 1)**.
3. Once the center splash guard is removed, also remove the (2) fasteners holding each plastic cover located on the driver and passenger side, **(Figure 2)**. It is not necessary to remove the (2) plastic covers, only remove the clips.
4. Select the driver side Mounting Bracket and hold it in position by inserting (1) 10mm x 80mm Hex Bolt with (1) 10mm x 20mm Flat Washer up through the outer hole in the Bracket and up through the body mount, **(Figure 3)**. Secure with (1) 10mm x 27mm Large Flat Washer, (1) 10mm Lock Washer and (1) 10mm Hex Nut, **(Figure 4)**. **NOTE:** Carefully pull the plastic corner cover out of the way to access the top of the body mount.
5. Next, select the driver side Support Bracket and hold it in place over the inner hole in the Bracket and body mount. Insert (1) 10mm x 80mm Hex Bolt with (1) 10mm x 20mm Flat Washer through the inner hole in the Bracket and up through the body mount and finally the Support Bracket. Secure with (1) 10mm x 27mm Large Flat Washer, (1) 10mm Lock Washer

and (1) 10mm Hex Nut, (**Figure 5A & 5B**). Snug but do not tighten hardware at this time.

NOTE: The tab on the Support Bracket will mount to the inside surface on the Mounting Bracket with the Sport Bar on the outside of the Mounting Bracket, (**Figure 5A, 5B & 5C**).

6. Repeat **Steps 4 & 5** for passenger side Mounting Bracket installation.
7. Hold the center splash guard up in the original location against the Mounting Brackets and mark the area that will need to be removed to clear the Brackets, (**Figure 6A & 6B**). **NOTE:** To maintain the integrity of the splash guard, make several small cuts and only remove material required for clearance, (**Figure 6B**). Once the splash guard has been properly trimmed, remove the Mounting Brackets. Fasten the splash guard at the bumper cover, (front edge), only at this time to hold the splash guard in position. Insert the driver side Mounting Bracket through the opening cut in the splash guard. Bolt the Mounting Bracket in position as described in **Steps 4 & 5**. Repeat for passenger side Mounting Bracket installation. Leave the splash guard loose at this time.
8. With assistance, carefully position the Sport Bar up to the outside of the Mounting Brackets. Attach the Sport Bar to the Mounting Brackets using the included (2) 12mm x 40mm Hex Bolts (insert these longer bolts through the Support Bracket and Mounting Bracket), (2) 12mm x 35mm Hex Bolts toward the front, (8) 12mm Flat Washers, (4) 12mm Lock Washers and (4) 12mm Hex Nuts, (**Figure 7**). Snug but do not tighten hardware at this time.
9. Level and adjust the Sport Bar and tighten all hardware. Trim the splash guard for clearance as required. Reinstall the splash guard using the factory hardware.
10. Reinstall the (2) plastic corner covers using the factory hardware.
11. Do periodic inspections to the installation to make sure that all hardware is secure and tight.

To protect your investment, wax this product after installing. Regular waxing is recommended to add a protective layer over the finish. Do not use any type of polish or wax that may contain abrasives that could damage the finish.

For stainless steel: Aluminum polish may be used to polish small scratches and scuffs on the finish. Mild soap may be used also to clean the Sport Bar.

For gloss black finishes: Mild soap may be used to clean the Sport Bar.

Driver Side Installation Pictured



Fig 1

Remove factory hardware to remove the center splash guard

Important: Note that there are (2) clips behind the front bumper cover that are difficult to reach

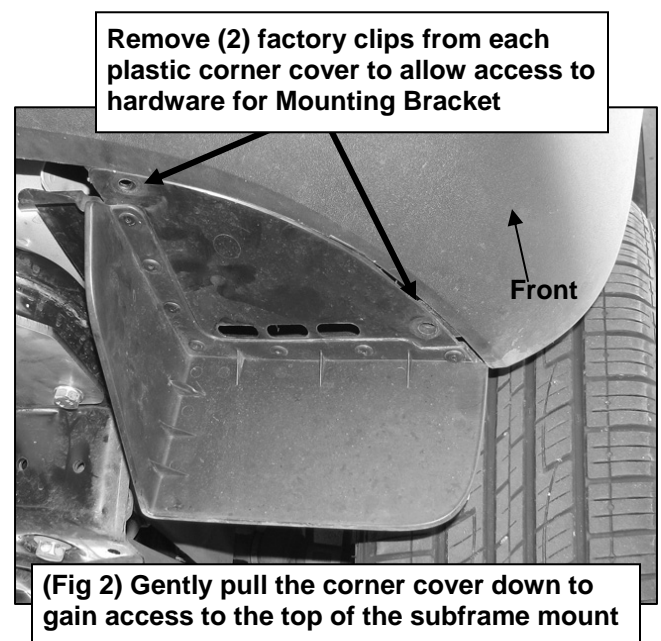

(Fig 2) Gently pull the corner cover down to gain access to the top of the subframe mount

Driver Side Installation Pictured

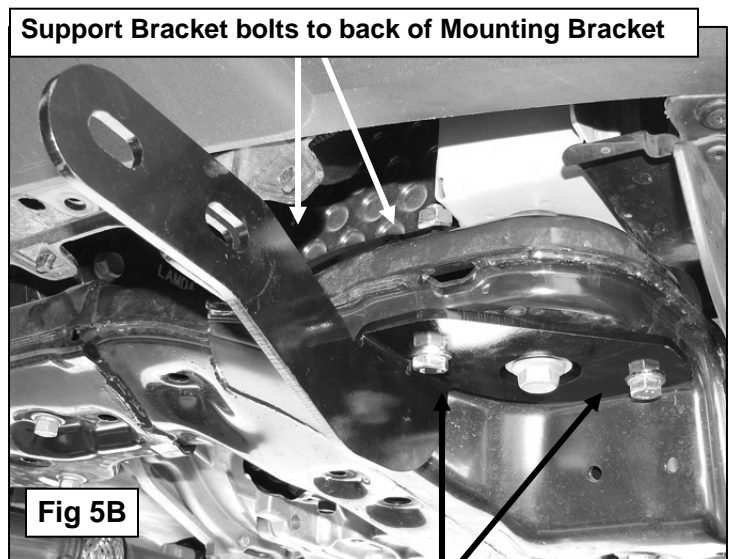
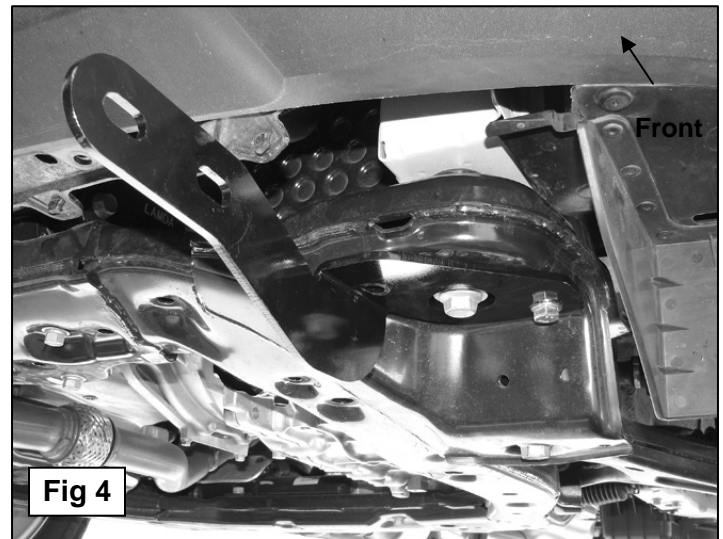

- (2) 10mm x 80mm Hex Bolts
- (2) 10mm x 27mm Large Flat Washers (top)
- (2) 10mm x 20mm Flat Washers (bottom)
- (2) 10mm Lock Washers
- (2) 10mm Hex Nuts



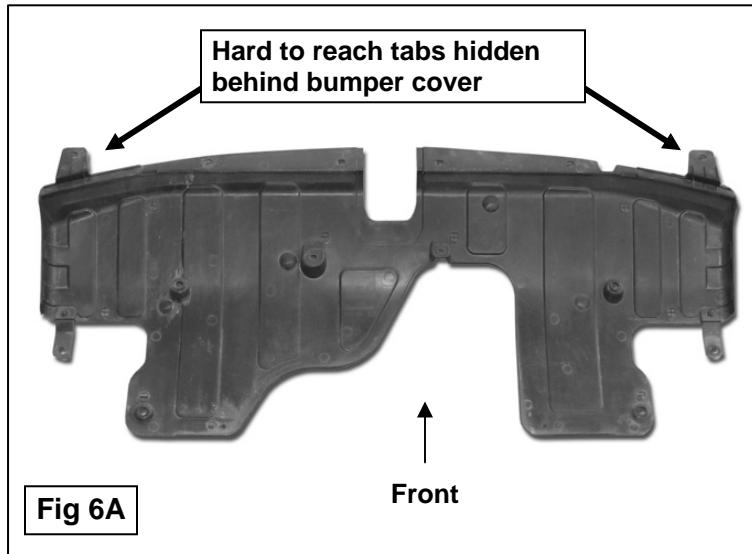

Cut (2) slots for Mounting Bracket clearance. Illustration is for reference only, actual cut out required for clearance may differ

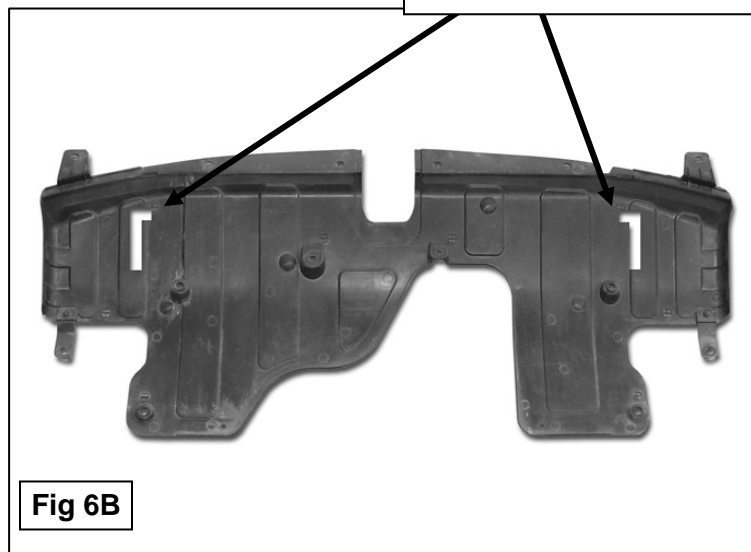

12mm x 35mm Hex Bolt
(2) 12mm Flat Washers
12mm Lock Washers
12mm Hex Nuts

12mm x 40mm Hex Bolt-through Support Bracket
(2) 12mm Flat Washers
12mm Lock Washers
12mm Hex Nuts

