

Installation Instructions

I - Sheet Number AVR21 Rev.A



Aerovisor® Deflector

For proper installation and best possible fit, please read all instructions **BEFORE** you begin.
For technical assistance or to obtain missing parts, please call Customer Relations at 1-800-241-7219.

Important Safety Information



- CAUTION - Before driving, ensure that the vent visor is properly secured to vehicle.
- Do not use automatic "brush-style" car washes.
- Do not use cleaning solvents of any kind.
- Periodically check all components for tightness.

Contents **NOTE:** Actual product may vary from illustration.

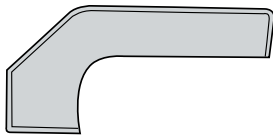

Front Driver Side Visor

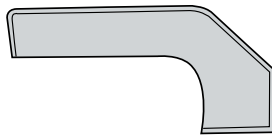

Front Passenger Side Visor



Alcohol Pad x2



Scotch Brite Pad

Tools Required



Car Wash Supplies



Clean Towel

Preparation Before Painting / Installation

- A trial fit is recommended to ensure proper positioning and fit.
- Check fit of parts before painting as we will not accept the return of modified or painted parts.
- Wash and dry your vehicle to remove any debris and/or dirt from the installation area.

Installation Steps **NOTE:** Actual application may vary slightly from illustrations.



Buff the lower rubber window channel and rubber window adjacent to the mirror cap with the Scotch Brite Pad.

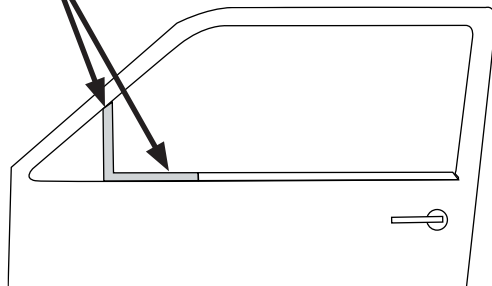

1



Clean the painted surface along the top of the door frame and the lower rubber window channel with an alcohol pad. Wipe dry with a soft cloth.

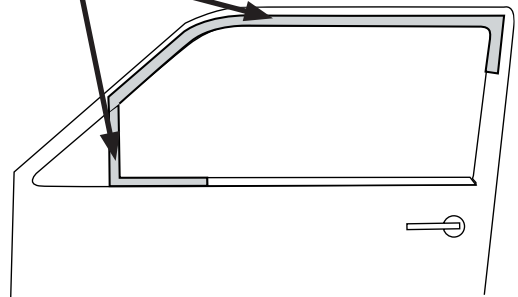

2

Installation Steps

NOTE: Actual application may vary slightly from illustrations.

Peel back 2" (5 cm) of tape liner from each end of the visor.

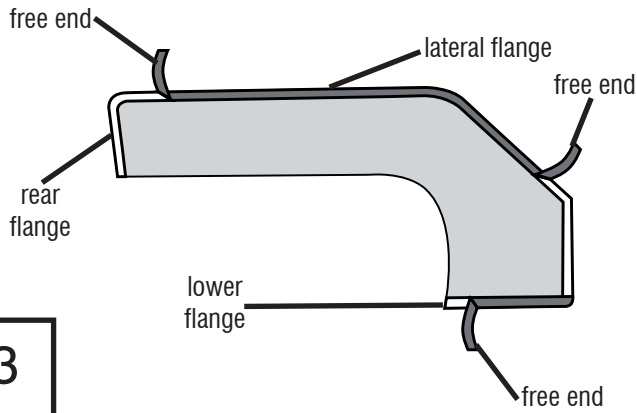

3

Align the deflector on the door. The lateral flange will attach to the painted metal surface and the lower flange will attach to the rubber window channel adjacent to the mirror. Attach the front end flange to the rubber window channel adjacent to the mirror cap.

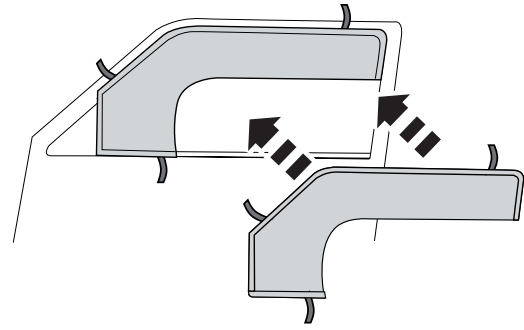

4

Gently press the exposed areas of tape against the surface and verify position.

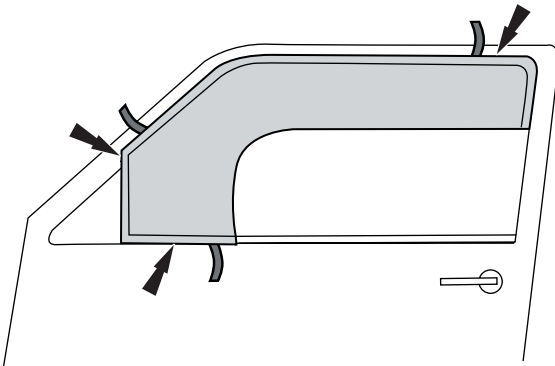

5

With the visor in its final position, remove the remaining tape liner by pulling on free ends.

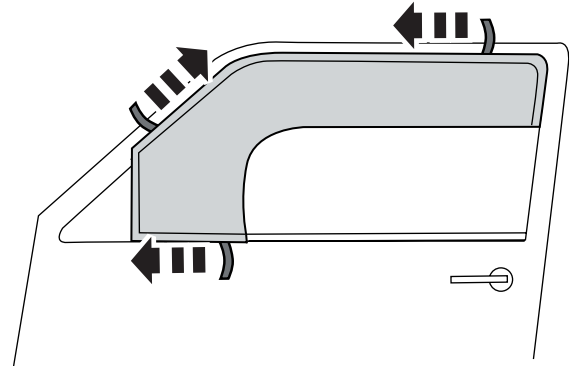

6

Apply pressure along all flanges to ensure proper adhesion of tape.

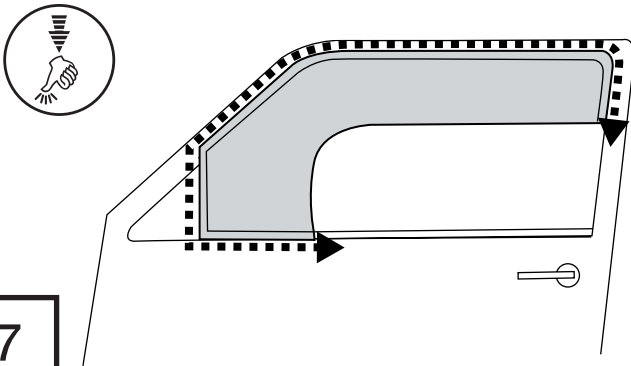

7

Repeat **Steps 1-7** for opposite side.

Care and Cleaning

- Wash only with mild soap & dry with a clean cloth.

Congratulations!

You have purchased one of the many quality Auto Ventshade™ branded products offered by Lund International, Inc. We take the utmost pride in our products and want you to enjoy years of satisfaction from your investment. We have made every effort to ensure that your product is top quality in terms of fit, durability, finish and ease of installation.



AUTO VENTSHADE™

Lund International, Ventshade Accessories Division

655 Raco Drive, Lawrenceville, GA 30045

800-241-7219 • Fax 770-339-5839 • Visit us at lundinternational.com

© 2006 Lund International, Inc. All rights reserved.

Auto Ventshade™, the Auto Ventshade™ logo and the AVS™ logo are trademarks of Lund International, Inc.





Aerovisor Deflector

Pour obtenir une installation correcte et le meilleur ajustement possible, lire toutes les instructions AVANT de commencer.
 Pour toute assistance technique ou obtention de pièces manquantes, appeler le service des relations avec la clientèle au 1-800-241-7219.

Informations importantes concernant la sécurité



- ATTENTION – Avant de conduire, s'assurer que la visière est solidement assujettie sur le véhicule.
- Ne pas utiliser les stations de lavage de voitures à brosses.
- Ne pas utiliser de solvants.
- Vérifier régulièrement le serrage des composants.

Contenu **NOTE:** Le produit réel peut changer de l'illustration.

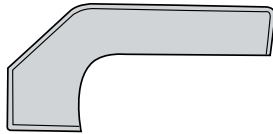

Visière avant côté conducteur

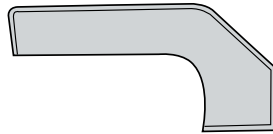

Visière avant côté passager



Tampons à l'alcool (2)



tampon à récurer Scotch Brite

Outils nécessaires



Fournitures pour lavage de voiture



Serviette propre

Préparation pour la peinture/l'installation

- Il est recommandé de procéder à un essai pour s'assurer que le positionnement et l'ajustement sont corrects.
- Vérifier l'ajustement des pièces avant peinture, car nous n'acceptons pas le retour de pièces modifiées ou peintes.
- Laver les glissières de glaces de la portière du véhicule pour éliminer toute poussière et tous débris.
- Sécher les glissières avec une serviette propre.

Étapes d'installation **REMARQUE :** La méthode d'application peut être légèrement différente de celle représentée par les illustrations.



Frotter la glissière inférieure en caoutchouc de la glace et la garniture en caoutchouc de la glace adjacente au couvercle du rétroviseur avec le tampon à récurer Scotch Brite.

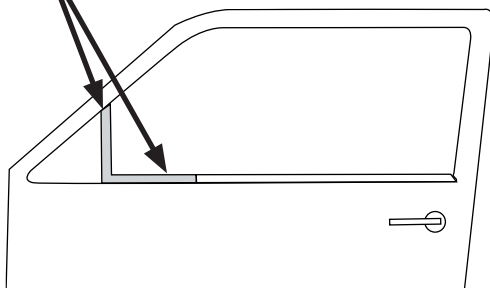

1



Avec un tampon à l'alcool, nettoyer la surface peinte le long du haut du cadre de portière ainsi que la glissière inférieure en caoutchouc de la glace. Sécher avec un chiffon doux.

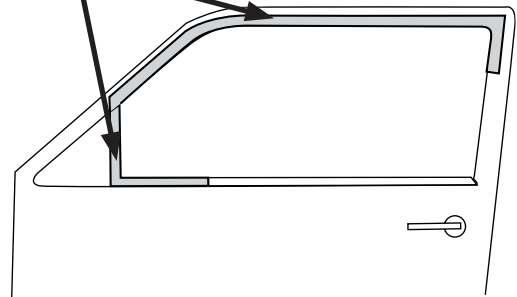

2

Étapes d'installation

REMARQUE : La méthode d'application peut être légèrement différente de celle représentée par les illustrations.

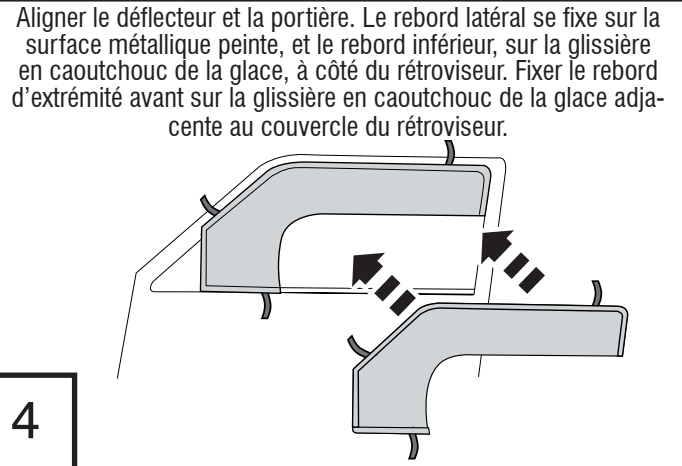
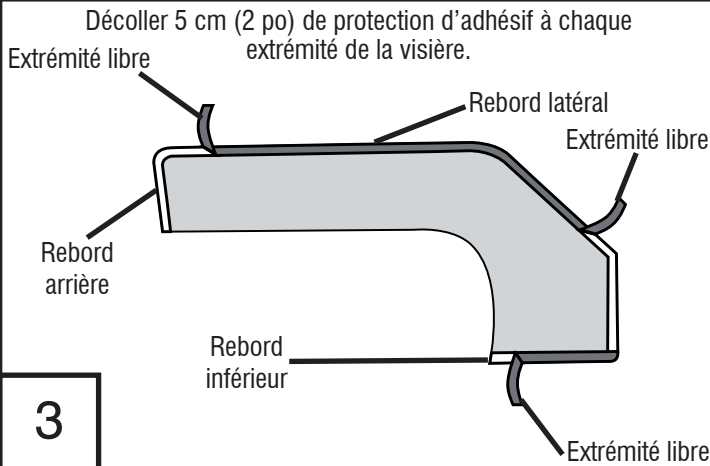

Pousser doucement les parties exposées du ruban adhésif contre la surface et vérifier la position.

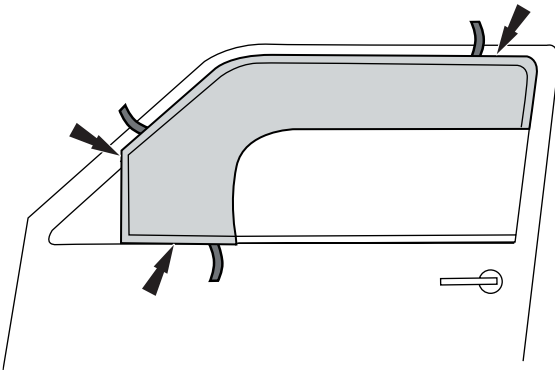

Une fois la visière en position finale, retirer le reste de la protection d'adhésif en tirant sur les extrémités libres.

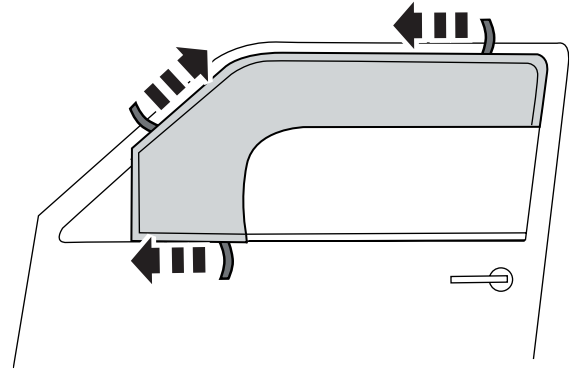

Appuyer le long de tous les rebords pour assurer la bonne adhésion de la bande adhésive.

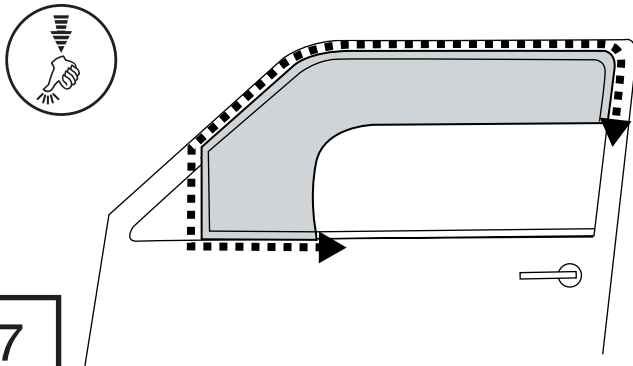

Répéter les **étapes 1 à 7** pour le côté opposé.

Entretien et nettoyage

- Laver exclusivement avec de l'eau savonneuse et sécher avec un chiffon propre.

Félicitations !

Vous avez acheté l'un des nombreux produits de qualité Auto Ventshade™ fabriqués par Lund International, Inc. Nous sommes extrêmement fiers de nos produits et souhaitons que vous tiriez des années de satisfaction de votre investissement. Nous avons pris toutes les mesures nécessaires pour assurer que ce produit est d'une qualité supérieure en ce qui concerne l'ajustement, la durabilité, la finition et la facilité d'installation.



AUTO VENTSHADE™
Lund International, Ventshade Accessories Division
655 Raco Drive, Lawrenceville, GA 30045, USA

800-241-7219 • Fax 770-339-5839 • Visitez notre site lundinternational.com

© 2005 Lund International, Inc. Tous droits réservés.

Auto Ventshade™, le logo Auto Ventshade™ et le logo AVS™ sont des marques déposées de Lund International, Inc.





Aerovisor® Deflector

Para una instalación adecuada y el mejor ajuste posible, lea todas las instrucciones ANTES de comenzar. Si desea recibir asistencia técnica u obtener piezas faltantes, llame al Servicio al cliente al 1-800-241-7219.

Información importante de seguridad



- PRECAUCIÓN - Antes de conducir, asegúrese de que la visera esté correctamente anclada al vehículo.
- No utilice servicios automáticos de limpieza de vehículos que utilizan cepillos.
- No utilice limpiadores al solvente de ningún tipo.
- Compruebe periódicamente que todos los componentes estén ajustados.

Contenido

NOTA: El producto real puede variar de la ilustración.

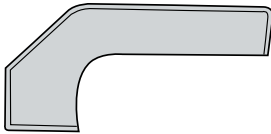

Visera delantera del conductor

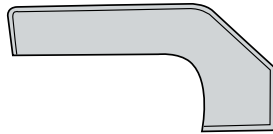

Visera delantera del acompañante



Paños esterilizados x 2



el paño Scotch Brite

Herramientas necesarias



Equipo de limpieza de vehículos



Toalla limpia

Preparación antes de pintar o instalar

- Se recomienda realizar un ajuste de prueba para asegurar el posicionamiento y ajuste correctos.
- Compruebe que las piezas se ajusten correctamente antes de pintarlas, ya que no aceptaremos la devolución de piezas modificadas o pintadas.
- Lave los canales de la ventanilla del vehículo para quitar los desechos y la suciedad.
- Seque los canales de la ventanilla con una toalla limpia.

Pasos de instalación

AVISO: La colocación real puede variar con respecto a las ilustraciones.



Pula el canal de goma inferior de la ventanilla y la banda de goma de la ventanilla adyacente a la cubierta del espejo con el paño Scotch Brite.

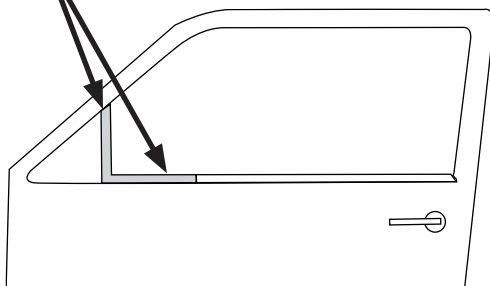

1



Limpie la superficie pintada que se extiende a lo largo de la parte superior del marco de la puerta y el canal de goma inferior de la ventanilla con un paño esterilizado. Séquela con un paño suave.

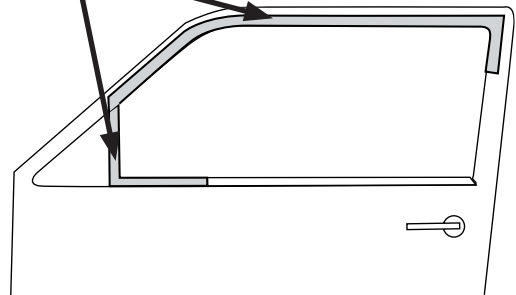

2

Pasos de instalación

AVISO: La colocación real puede variar con respecto a las ilustraciones.

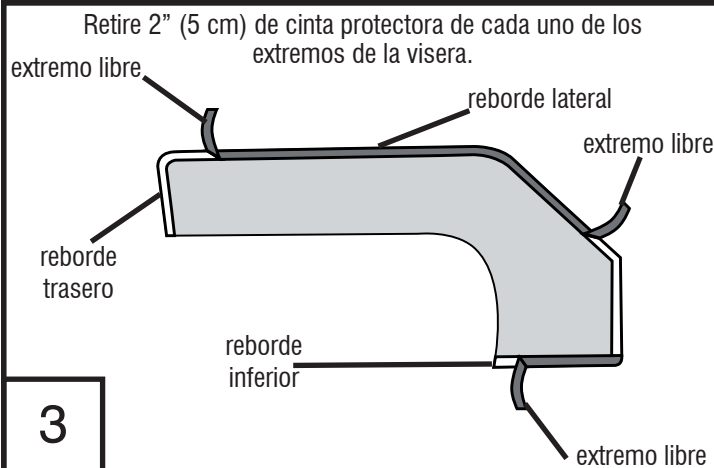

Alinee el deflector con la puerta. El reborde lateral se colocará en la superficie metálica pintada y el reborde inferior se colocará en el canal de goma de la ventanilla adyacente al espejo. Coloque el extremo del reborde frontal en el canal de goma de la ventanilla adyacente a la cubierta del espejo.

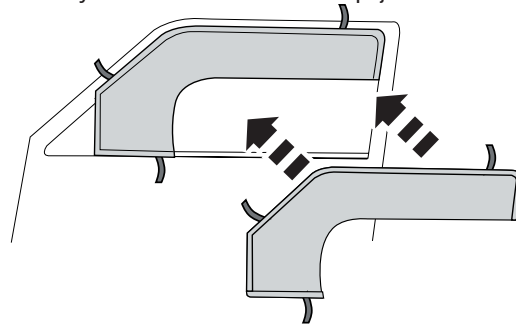

3

4

Presione suavemente las áreas expuestas de la cinta contra la superficie y verifique la posición.

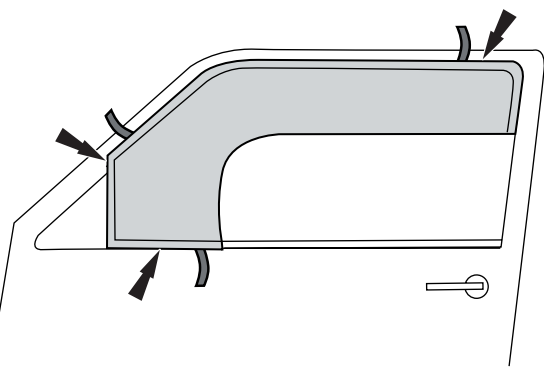

Una vez que la visera se encuentre en su posición definitiva, quite la cinta protectora restante tirando de los extremos libres.

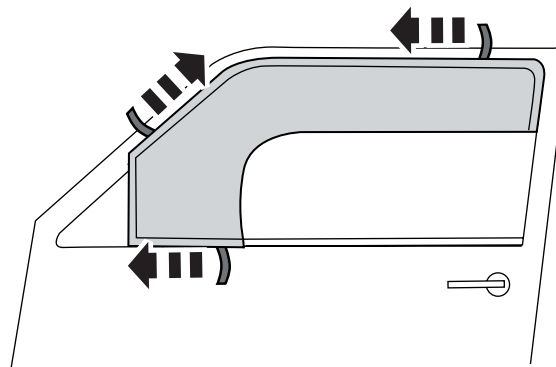

5

6

Presione todos los rebordes para asegurarse de que la cinta se adhiera correctamente.

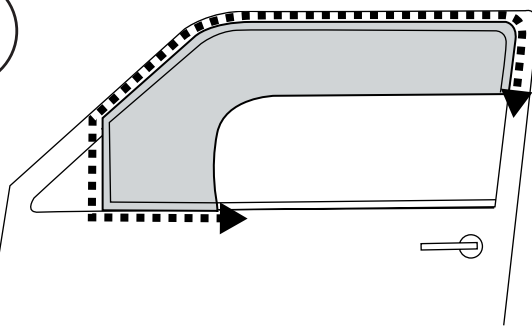

Repita los Pasos 1 al 7 para el otro lado del vehículo.

7

Cuidado y limpieza

- Limpie solamente con agua jabonosa tibia y seque con un paño limpio.

Felicidades

Usted ha comprado uno de los tantos artículos de calidad de Auto Ventshade™ ofrecidos por Lund International, Inc. Nuestros productos son nuestro mayor orgullo. Deseamos que disfrute de años de satisfacción con su inversión. Hemos realizado todos los esfuerzos para asegurarnos de que su producto sea de la mejor calidad en cuanto a ajuste, durabilidad, acabado y facilidad de instalación.



Lund International, Ventshade Accessories Division
655 Raco Drive, Lawrenceville, GA 30045

800-241-7219 • Fax 770-339-5839 • Visite nuestro sitio Web: lundinternational.com

© 2005 Lund International, Inc. Todos los derechos reservados.



Auto Ventshade™, el logo de Auto Ventshade™ y el logo de AVS™ son marcas comerciales de Lund International, Inc.

